

# Crystal Clear Technology

## Product Specification

### **C108x01 series**

Crystal Clear Technology sdn. bhd.

16Jalan TP5—Taman Perindustrian Sime UEP  
47600 Subang Jaya—Selangor DE  
Malaysia. T: +603 80247099 F: +603 80247098

---



1.0 Table of Contents

	Page
1. Table of Contents	1
2. Record of revision	2
3. General specification	3
4. Absolute maximum ratings	4
5. Electrical characteristics	4
6. Environmental requirement	4
7. LCD specification	5 ~ 7
8. Interfacing	8
9. Timing characteristics	9 ~ 10
10. Power supply	11
11. Block diagram	11
12. Instructions	12 ~ 15
13. Quality assurance	16 ~ 17
14. Precautions in use LCM	18 ~ 19
15. Mechanical drawing	20



2.0 Record of revision

Rev	Date	Item	Page	Comment	Originator	Checked By
1.0	04/06/08			Initial Release	Syam	Azhar



3.0 General specification

Display format: 1 lines x 8 characters

Character font format: 5 x 8

Character size: 6.45mm x 10.75mm

View area: 61.0mm x 15.8mm

Active area: 56.5mm x 10.75mm

General dimensions: 84.0mm x 44.0mm

Controller/Driver: SPLC780 or equivalent

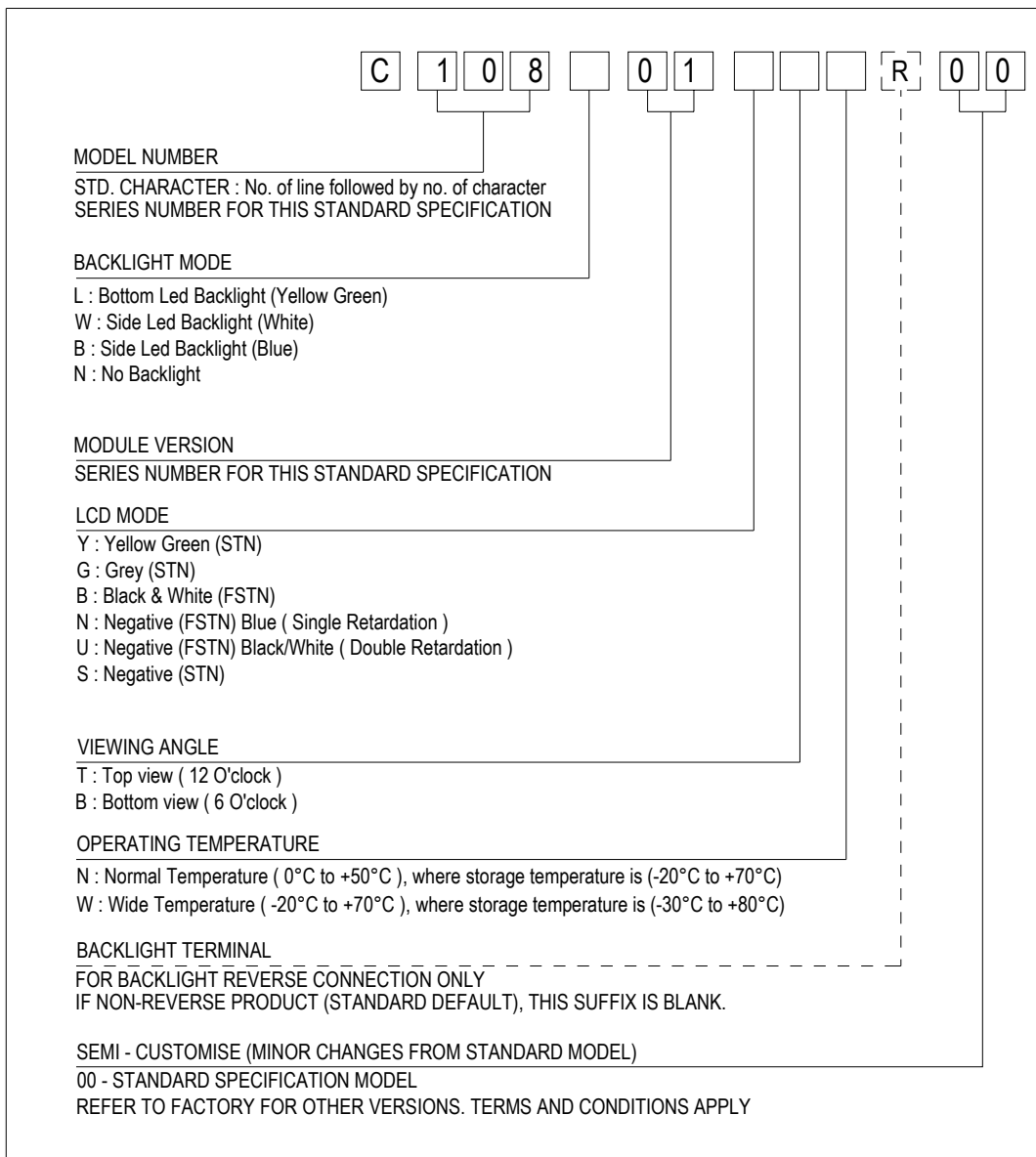

**4.0 Absolute maximum rating (at V<sub>SS</sub> = 0V, ambient temperature = 25°C)**

NO	ITEM	SIMBOL	MIN	MAX	UNIT
1.	Power Supply voltage (Logic)	V <sub>DD</sub> - V <sub>SS</sub>	0	7	V
2.	Power Supply voltage (LCD Driver)	V <sub>DD</sub> - V <sub>0</sub>	-	12	V
3.	Operating Temperature	T <sub>op</sub>	Refer page 3		°C
4.	Storage Temperature	T <sub>st</sub>	Refer page 3		°C

**5.0 Electrical characteristics**

NO	ITEM	SYMBOL	CONDITION	MIN	TYP	MAX	UNIT
1.	Power Supply voltage (Logic)	V <sub>DD</sub> - V <sub>SS</sub>	-	4.5	5.0	5.5	V
2.	Power Supply voltage (V <sub>LCD</sub> )	V <sub>DD</sub> -V <sub>0</sub>	25°C	4.5±5%			V
3.	Input Voltage (except OSC1)	V <sub>IH</sub>	-	0.7V <sub>DD</sub>	-	V <sub>DD</sub>	V
		V <sub>IL</sub>	-	-0.3	-	0.6	V
4.	Current Supply	I <sub>DD</sub>	V <sub>DD</sub> - V <sub>SS</sub> = 5V	-	1.0	2.0	mA

**5.1 Backlight Options**

NO	COLOR	FORWARD VOLTAGE (V)			FORWARD CURRENT (mA)			MIN BRIGHTNESS (cd/m <sup>2</sup> ) *
		Min	Typ.	Max	Min	Typ.	Max	
1.	Yellow Green	-	4.0	-	-	60	100	60
2.	White	-	3.6	-	-	20	30	20
3.	Blue	-	3.6	-	-	20	30	8

- \*Note : 1. Brightness measured at backlight surface.  
 2. On LCD surface, brightness is only about 10% to 15% of backlight brightness.  
 3. Lifetime of backlight: For YG = 50K hrs. For White, Blue = 20K hrs

**6.0 Environmental requirements**

NO	ITEM	CONDITION
1.	Operating Temperature	Refer page 3
2.	Storage Temperature	Refer page 3
3.	Operating Humidity	5% to 95%RH
4.	Cycle Test	-20 °C @ 30 min to 70 °C @ 30min for 1 cycle run for 10 cycles
5.	Lifetime	50000 HOURS (excluding backlight)

Note: The background on LCD has the possibility to be changed in different temperature range.



## 7.0 LCD specification

## 7.1 Electro-optical characteristics (at ambient temperature = 25°C)

NO	ITEM	SYMBOL	CONDITION	LCD TYPE						REF.
				STN YG	STN GREY	STN -VE BLUE	FSTN +VE B/W	FSTN -VE BLUE	FSTN -VE TRUE B/W	
1	Operating Voltage (Volt)	$V_{LCD}$	$\theta = 0$ $Cr = \max$	4.5 ± 5%						7.1.1
2	Viewing Angle (Deg)	$\theta_x 1$	$CR \geq 2$ $V_{LCD} = 4.5V$	+30	+25	+40	+30	+40	+40	7.1.2
		$\theta_x 2$		-30	-25	-40	-30	-40	-45	
		$\theta_y 1$		-35	-30	-40	-35	-40	-40	
		$\theta_y 2$		+35	+30	+40	+35	+40	+40	
3	Contrast Ratio	CR	$\theta = 0^0$ $V_{LCD} = 4.5V$	4.0	2.5	7.0	4.0	7.0	25	7.1.3
4	Response Time (msec)	Rise Time (Tr)	$\theta = 0^0$	150						7.1.4
		Decay Time (Td)	$\theta = 0^0$	150						

## Note:

1. Viewing angle data is based on bottom view product by default. Should it be a top view product, values are then swap.
2. Contrast ratio is based on typical data when using white colour as backlight.
3. Equipment Used Eldim; Ez Contrast 120R , Spot Size = 2mm

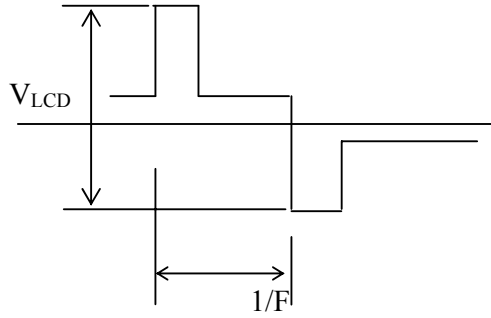
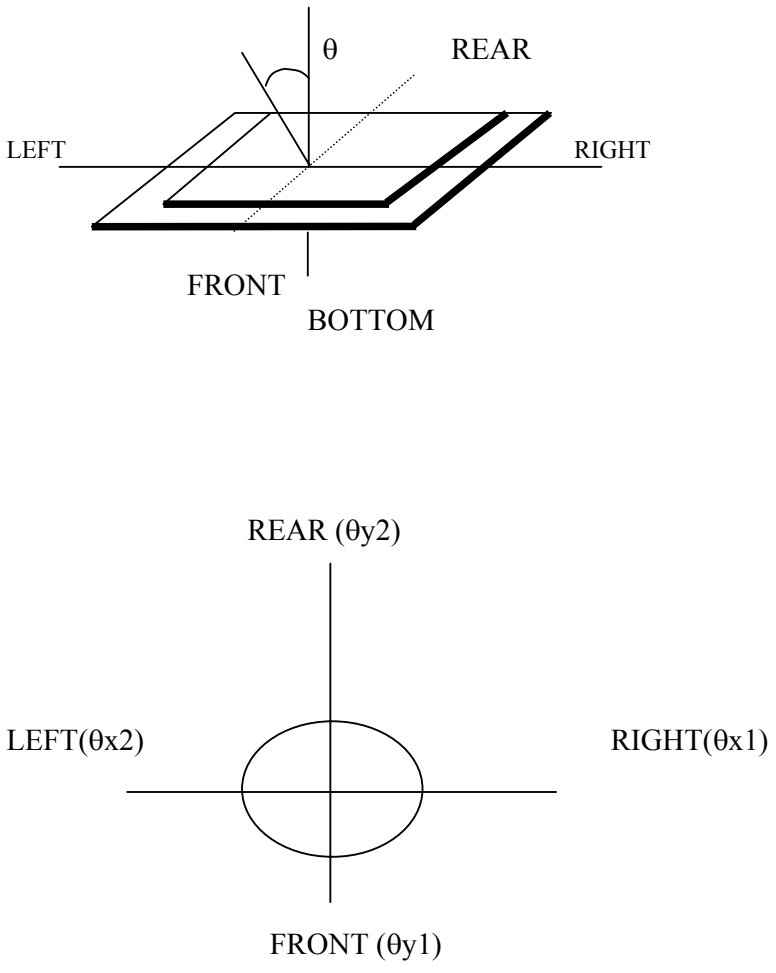

NO	CHARACTERISTICS	DEFINITIONS
7.1.1	<b>Definition of Operating Voltage (<math>V_{LCD}</math>)</b>	 <p><math>V_{LCD}</math> : Operating Voltage F : Frame Frequency</p>
7.1.2	<b>Definition of Viewing Angle</b>	 <p>3D diagram showing viewing angle <math>\theta</math> relative to the normal of the display surface. The surface is labeled with FRONT, REAR, LEFT, and RIGHT.</p> <p>2D diagram showing viewing angles <math>\theta_{x1}</math>, <math>\theta_{x2}</math>, <math>\theta_{y1}</math>, and <math>\theta_{y2}</math> relative to the axes of the display surface.</p>

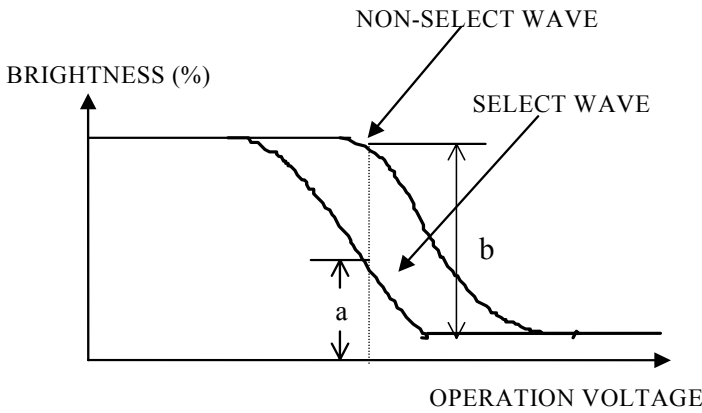
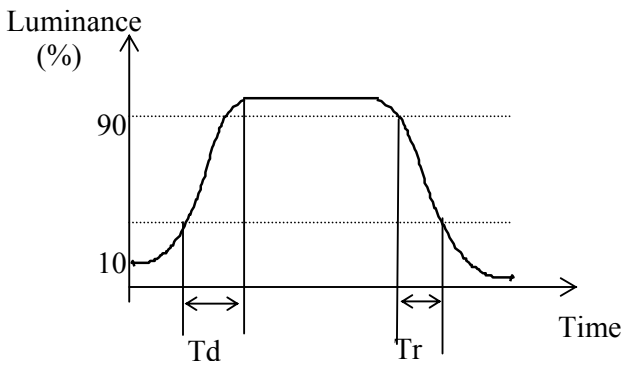

<p>7.1.3</p>	<p><b>Definition of Contrast Ratio</b></p>	 <p>Contrast Ratio = <math>\frac{\text{Brightness of non-selected state (b)}}{\text{Brightness of selected state (a)}}</math></p> <p><b>Conditions</b></p> <ul style="list-style-type: none"><li>(a) Operating Voltage: <math>V_{LCD}</math></li><li>(b) Temperature: <math>25^{\circ}C</math></li><li>(c) Viewing Angle, <math>\theta = 0^{\circ}</math></li></ul>
<p>7.1.4</p>	<p><b>Response Time</b></p>	 <p><math>T_r</math>: Measured between 10% and 90% of LCD segment maximum response with <math>V_{ON}</math>.</p> <p><math>T_d</math>: With voltage switches to zero and the instant LCD segment reaches 10% of its maximum response.</p>



8.0 Interface

<b>8.1</b>	<b>Display Driver</b>	SPLC780	
<b>8.2</b>	<b>Duty Cycle</b>	1/8	
<b>8.3</b>	<b>Pin-out Assignments</b>		
	<b>Pin No</b>	<b>Symbol</b>	<b>Description</b>
	1	V <sub>SS</sub>	Ground terminal of module
	2	V <sub>DD</sub>	Supply terminal of module
	3	V <sub>O</sub>	Power supply for Liquid Crystal Drive
	4	RS	Register Select: RS = 0 .... Instruction Register RS = 1 .... Data Register
	5	R/W	Read/Write: High = Read Low = Write
	6	E	Enable
	7 to 14	D0 to D7	Bi-directional Data Bus. Data Transfer is performed once, thru D0 to D7, in the case of interface data length is 8-bits.
	15	(BL -)	LED power supply terminals
	16	(BL +)	



9.0 Timing Characteristics/Timing Diagrams

Characteristic	Symbol	Min.	Typ.	Max.	Unit	Test pin
E cycle time	$t_c$	500	---	---	ns	E
E rise time	$t_r$	---	---	25	ns	E
E fall time	$t_f$	---	---	25	ns	E
E pulse width (High, Low)	$t_w$	220	---	---	ns	E
R/W and RS set-up time	$t_{SU1}$	40	---	---	ns	R/W, RS
R/W and RS hold time	$t_{H1}$	10	---	---	ns	R/W, RS
Data set-up time	$t_{SU2}$	60	---	---	ns	DB <sub>0</sub> ~DB <sub>7</sub>
Data hold time	$t_{H2}$	10	---	---	ns	DB <sub>0</sub> ~DB <sub>7</sub>

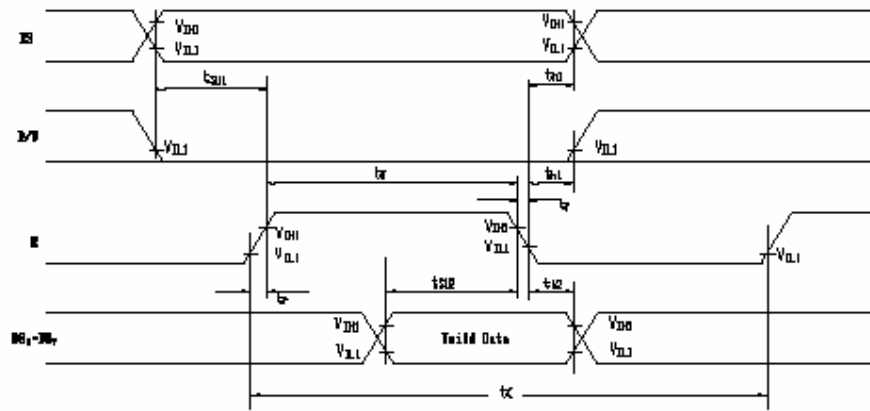

Write mode



Characteristic	Symbol	Min.	Typ.	Max.	Unit	Test pin
E cycle time	$t_c$	500	---	---	ns	E
E rise time	$t_r$	---	---	25	ns	E
E fall time	$t_f$	---	---	25	ns	E
E pulse width	$t_w$	220	---	---	ns	E
R/W and RS set-up time	$t_{SU}$	40	---	---	ns	R/W, RS
R/W and RS hold time	$t_h$	10	---	---	ns	R/W, RS
Data output delay time	$t_D$	---	---	120	ns	DB <sub>0</sub> ~ DB <sub>7</sub>
Data hold time	$t_{DH}$	20	---	---	ns	DB <sub>0</sub> ~ DB <sub>7</sub>

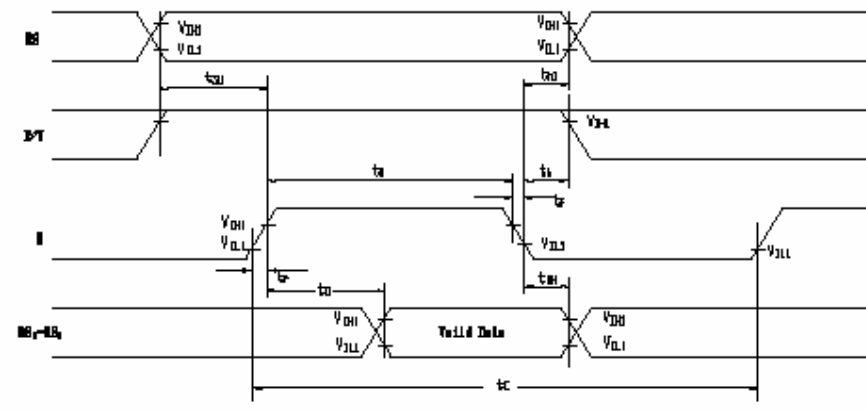

Read mode



10.0 Power Supply

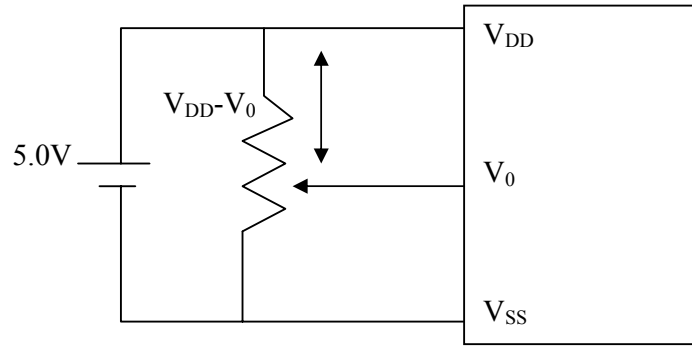

Where  $V_{DD}-V_0 = \text{LCD Driving voltage}$

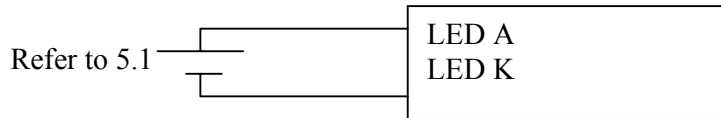

For backlight version only

11.0 Block Diagram

1	2	3	4	5	6	7	8	9	10	11	12	13	14	15	16
VSS	VDD	VO	RS	R/W	E	DB0	DB1	DB2	DB3	DB4	DB5	DB6	DB7	BLA	BLK

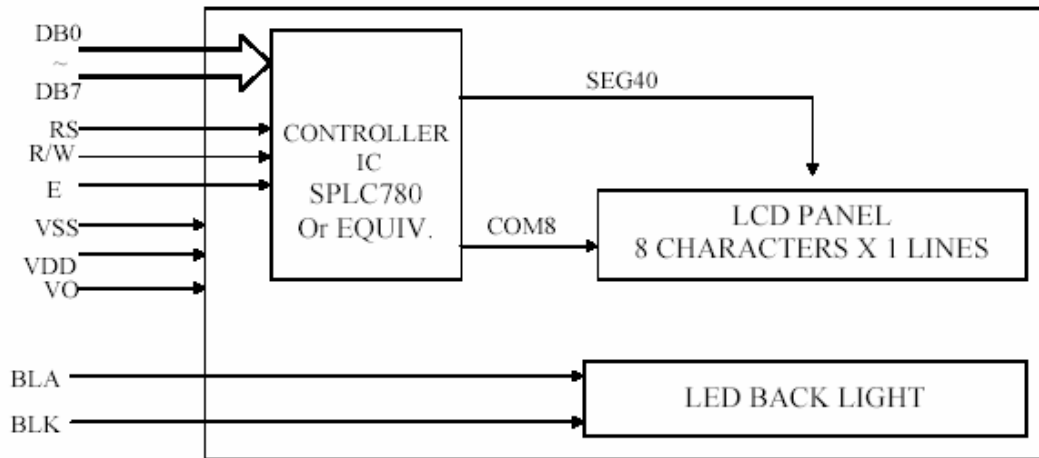



12.0 Instructions

Command	RS	R/W	DB <sub>7</sub>	DB <sub>6</sub>	DB <sub>5</sub>	DB <sub>4</sub>	DB <sub>3</sub>	DB <sub>2</sub>	DB <sub>1</sub>	DB <sub>0</sub>	Execution Time (t <sub>enc</sub> = 250kHz)	Remark																		
DISPLAY CLEAR	L	L	L	L	L	L	L	L	L	H	1.64ms																			
RETURN HOME	L	L	L	L	L	L	L	L	H	X	1.64ms	Cursor move to first digit																		
ENTRY MODE SET	L	L	L	L	L	L	L	H	I/D	SH	42µs	<ul style="list-style-type: none"> <li>I/D : Set cursor move direction <table border="1"> <tr> <td>I/D</td> <td>H</td> <td>Increase</td> </tr> <tr> <td></td> <td>L</td> <td>Decrease</td> </tr> </table> </li> <li>SH : Specifies shift of display <table border="1"> <tr> <td>SH</td> <td>H</td> <td>Display is shifted</td> </tr> <tr> <td></td> <td>L</td> <td>Display is not shifted</td> </tr> </table> </li> </ul>	I/D	H	Increase		L	Decrease	SH	H	Display is shifted		L	Display is not shifted						
I/D	H	Increase																												
	L	Decrease																												
SH	H	Display is shifted																												
	L	Display is not shifted																												
DISPLAY ON/OFF	L	L	L	L	L	L	H	D	C	B	42µs	<ul style="list-style-type: none"> <li>Display <table border="1"> <tr> <td>D</td> <td>H</td> <td>Display on</td> </tr> <tr> <td></td> <td>L</td> <td>Display off</td> </tr> </table> </li> <li>Cursor <table border="1"> <tr> <td>C</td> <td>H</td> <td>Cursor on</td> </tr> <tr> <td></td> <td>L</td> <td>Cursor off</td> </tr> </table> </li> <li>Blinking <table border="1"> <tr> <td>B</td> <td>H</td> <td>Blinking on</td> </tr> <tr> <td></td> <td>L</td> <td>Blinking off</td> </tr> </table> </li> </ul>	D	H	Display on		L	Display off	C	H	Cursor on		L	Cursor off	B	H	Blinking on		L	Blinking off
D	H	Display on																												
	L	Display off																												
C	H	Cursor on																												
	L	Cursor off																												
B	H	Blinking on																												
	L	Blinking off																												
SHIFT	L	L	L	L	L	H	S/C	R/L	X	X	42µs	<table border="1"> <tr> <td>S/C</td> <td>H</td> <td>Display shift</td> </tr> <tr> <td></td> <td>L</td> <td>Cursor move</td> </tr> </table> <table border="1"> <tr> <td>R/L</td> <td>H</td> <td>Right shift</td> </tr> <tr> <td></td> <td>L</td> <td>Left shift</td> </tr> </table>	S/C	H	Display shift		L	Cursor move	R/L	H	Right shift		L	Left shift						
S/C	H	Display shift																												
	L	Cursor move																												
R/L	H	Right shift																												
	L	Left shift																												
SET FUNCTION	L	L	L	L	H	DL	N	F	X	X	42µs	<table border="1"> <tr> <td>DL</td> <td>H</td> <td>8 bits interface</td> </tr> <tr> <td></td> <td>L</td> <td>4 bits interface</td> </tr> </table> <table border="1"> <tr> <td>N</td> <td>H</td> <td>2 line display</td> </tr> <tr> <td></td> <td>L</td> <td>1 line display</td> </tr> </table> <table border="1"> <tr> <td>F</td> <td>H</td> <td>5 X 10 dots</td> </tr> <tr> <td></td> <td>L</td> <td>5 X 7 dots</td> </tr> </table>	DL	H	8 bits interface		L	4 bits interface	N	H	2 line display		L	1 line display	F	H	5 X 10 dots		L	5 X 7 dots
DL	H	8 bits interface																												
	L	4 bits interface																												
N	H	2 line display																												
	L	1 line display																												
F	H	5 X 10 dots																												
	L	5 X 7 dots																												
SET CG RAM ADDRESS	L	L	L	H	CG RAM address (corresponds to cursor address)					42µs	CG RAM Data is sent and received after this setting																			
SET DD RAM ADDRESS	L	L	H	DD RAM address					42µs	DD RAM Data is sent and received after this setting																				
READ BUSY FLAG & ADDRESS	L	H	BF	Address Counter used for both DD & CG RAM address					0µs	<table border="1"> <tr> <td>BF</td> <td>H</td> <td>Busy</td> </tr> <tr> <td></td> <td>L</td> <td>Ready</td> </tr> </table> <ul style="list-style-type: none"> <li>- Reads BF indication internal operating is being performed</li> <li>- Reads address counter contents</li> </ul>	BF	H	Busy		L	Ready														
BF	H	Busy																												
	L	Ready																												
WRITE DATA	H	L	Write Data					46µs	Write data into DD or CG RAM																					
READ DATA	H	H	Read Data					46µs	Read data from DD or CG RAM																					

X: Don't care



## 12.1 Initializing by internal reset circuit

The SPLC780 automatically initializes (resets) when the power is on using the internal reset circuit. The following instructions are executed in initialization. The busy flag is kept in busy state (BF=1) until initialization ends. The busy state is 10ms after VDD rises to 4.5V.

- (1) Display Clear
- (2) Function Set
  - DL = 1: 8-bit interface data
  - N = 0: 1-line display
  - F = 0: 5x7-dot character font
- (3) Display On/Off Control
  - D = 0: Display Off
  - C = 0: Cursor Off
  - B = 0: Blink Off
- (4) Entry Mode Set
  - I/D = 1: +1 (Increment)
  - S = 0: No Shift



12.2 Initializing by instructions

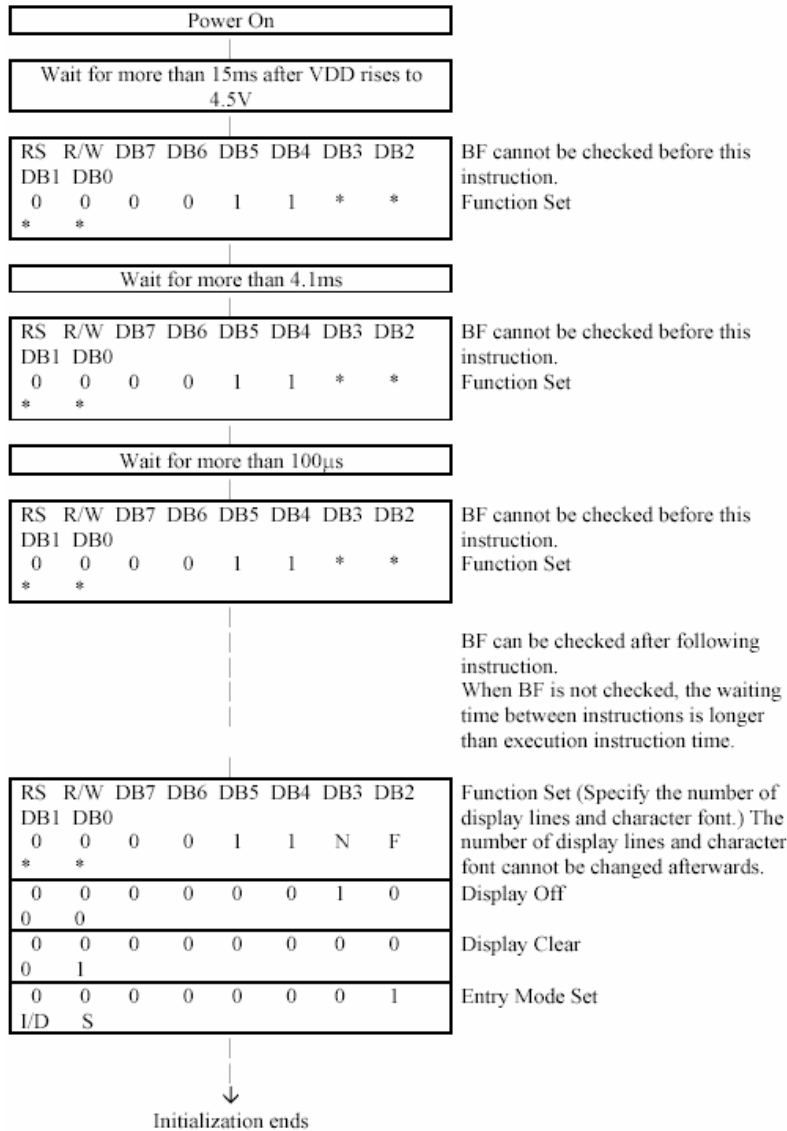



12.3 Character Generator ROM (SPLC780)

upper 4 bit lower 4 bit	0000	0010	0011	0100	0101	0110	0111	1000	1001	1010	1011	1100	1101	1110	1111
0000	CG RAM (1)														
0001	(8)														
0010	(8)														
0011	(4)														
0100	(5)														
0101	(6)														
0110	(7)														
0111	(8)														
1000	(1)														
1001	(8)														
1010	(8)														
1011	(4)														
1100	(5)														
1101	(6)														
1110	(7)														
1111	(8)														

12.4 Display data RAM address map

Characters	1	2	3	4	5	6	7	8	9	10	11	12	13	14	15	16
First line	00H	01H	02H	03H	04H	05H	06H	07H	40H	41H	42H	43H	44H	45H	46H	47H



13.0 Quality Assurance

13.1 ZONE DEFINITION

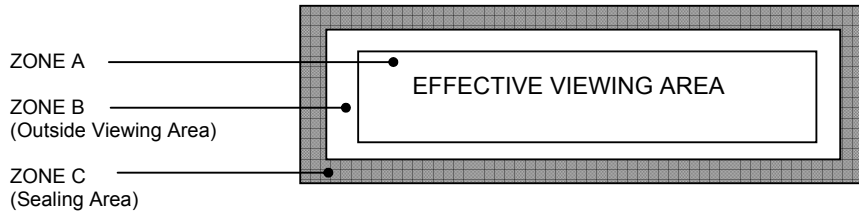

13.1.1 Black Spot, White Spot and Foreign Material

Defect Category	Defect Description	Criterion			Drawing Specification		
Black Spot, White Spot and Foreign Material	Black Spot, White Spot and Foreign Material	Zone / Dimension		Acceptable No.			<p>D = (A + B)/2</p>
				A	B	C	
		$D \leq 0.10\text{mm}$	NC	NC	NC		
		$0.10 < D \leq 0.20\text{mm}$	3	3	NC		
		$0.20 < D \leq 0.30\text{mm}$	1	2	NC		
		$D > 0.30\text{ mm}$	0	0	NC		
NC: No count D: Mean Diameter of Defect							

13.1.2 Line Shape and Scratches

Defect Category	Defect Description	Criterion			Drawing Specification		
Line shape and scratches	Line shape and scratches	Zone /Dimension		Acceptable No.			
		X	Y	A	B	C	
		-	<0.01mm	NC	NC	NC	
		< 2 mm	< 0.02mm	1	1	NC	
		<1 mm	< 0.0 2mm	1	2	NC	

13.1.3 Pin Hole

Defect Category	Defect Description	Criterion	Drawing Specification
Pin Hole	Pin hole / void at light up segment	$D \leq 0.20\text{mm}$ within 1 part/segment	<p>D = (A + B)/2</p>



13.1.4 Polarizer Bubble/Foreign Material

Defect Category	Defect Description	Criterion			Drawing Specification	
	Polarizer bubble / Foreign material	Zone / Dimension	Acceptable No.			<p><math>D = (A + B)/2</math></p>
		$D \leq 0.15\text{mm}$	NC	NC	NC	
		$0.15 < D \leq 0.30\text{mm}$	3	5	NC	
		$0.30 < D \leq 0.50\text{mm}$	2	3	NC	
		$0.50 < D \leq 1.0\text{mm}$	0	1	NC	
		NC: No count				
		D: Mean Diameter of Defect				
	Accept - if air bubble at the seal area does not propagate into effective viewing area					

Note: Total defects shall not exceed five



## 14. Precaution for using LCM

### 1. Liquid Crystal Display (LCD)

LCD is made up of glass, organic sealant, organic fluid and polymer based polarizers. The following precautions should be taken when handling.

- a) Keep the temperature within the range of use and storage. Excessive temperature and humidity could cause polarization degradation, polarizer peel off or bubble.
- b) Do not contact the exposed polarizer with anything harder than HB pencil lead. To clean dust off the display surface, wipe gently with cotton, chamois or other soft material soaked in petroleum benzin.
- c) Wipe off saliva or water drops immediately. Contact with water over a long period of time may cause polarizer deformation or colour fading, while an active LCD with water condensation on its surface will cause corrosion of ITO electrodes.
- d) Glass can be easily chipped or cracked from rough handling, especially at corners and edges.
- e) Do not drive LCD with DC voltage.

### 2. Liquid Crystal Display Modules.

#### 2.1 Mechanical Considerations

LCM are assembled and adjusted with a high degree of precision. Avoid excessive shocks and do not make any alterations or modification. The following should be noted.

- a) Do not tamper in any way with the tabs on the metal frame.
- b) Do not modify the PCB by drilling extra holes, changing its outline, moving its component or modifying its pattern.
- c) Do not touch the elastomer connector, especially insert a backlight panel (for example, EL)
- d) When mounting a LCM make sure that the PCB is not under any stress such as
- e) are very delicate and missing pixels could result from slight dislocation of any of the elements.

- f) Avoid pressing on the metal bezel, otherwise the elastomer connector could be deformed and lose contact, resulting in missing pixels.

#### 2.2 Static Electricity

LCM contains CMOS LSI's and the same precaution for such devices should apply, namely

- a) The operator should be grounded whenever he/she comes into contact with the module. Never touch any of the conductive parts such as the LSI pads, the copper leads on the PCB and the interface terminals with any parts of the human body.
- b) The modules should be kept in antistatic bags or other containers to static for storage.
- c) Only properly grounded soldering irons should be used.
- d) If an electric screwdriver is used, it should be well grounded and shielded from commutator spark.
- e) The normal static prevention measures should be observed for work clothes and working benches, the latter conductive (rubber) mat is recommended.
- f) Since dry air is inductive to statics, a relative humidity of 50-60% is recommended.

#### 2.3 Soldering

- a) Solder only to the I/O terminals.
- b) Use only soldering irons with proper grounding and no leakage.
- c) Soldering temperature: 280 °C
- d) Soldering time: 3 to 4 sec
- e) Use eutectic solder with resin flux fill.
- f) If flux is used, the LCD surface should be covered to avoid flux spatters. Flux residue should be removed afterwards.



#### 2.4 Operation

- a) The contrast can be adjusted by varying the LCD driving voltage  $V_0$
- b) Driving voltage should be kept within specified range, excess voltage shortens display life.
- c) Response time increases with decrease in temperature.
- d) Display may turn black or dark blue at temperature above its operational range, this is (however not pressing on the viewing area) may cause the segments to appear “fractured”.
- e) Mechanical disturbance during operation (such as pressing on the viewing area) may cause the segments to appear “fractured”.

#### 2.5 Storage

If any fluid leaks out of the damaged glass cell, wash off any human part that comes into contact with soap and water. Never swallow the fluid. The toxicity is extremely low but caution should be exercised at all the time.

#### 2.6 Limited Warranty

Unless otherwise agreed between Crystal Clear Technology and customer, Crystal Clear Technology will replace or repair any of its LCD and LCM which is found to be defective electrically and visually when inspected in accordance with Crystal Clear Technology acceptance standards, for a period of one year from date of shipment. Confirmation of such date shall be based on freight documents. The warranty liability of Crystal Clear Technology is limited to repair and/or replacement on the terms set forth above. Crystal Clear Technology will not be responsible for any subsequent or consequential events.

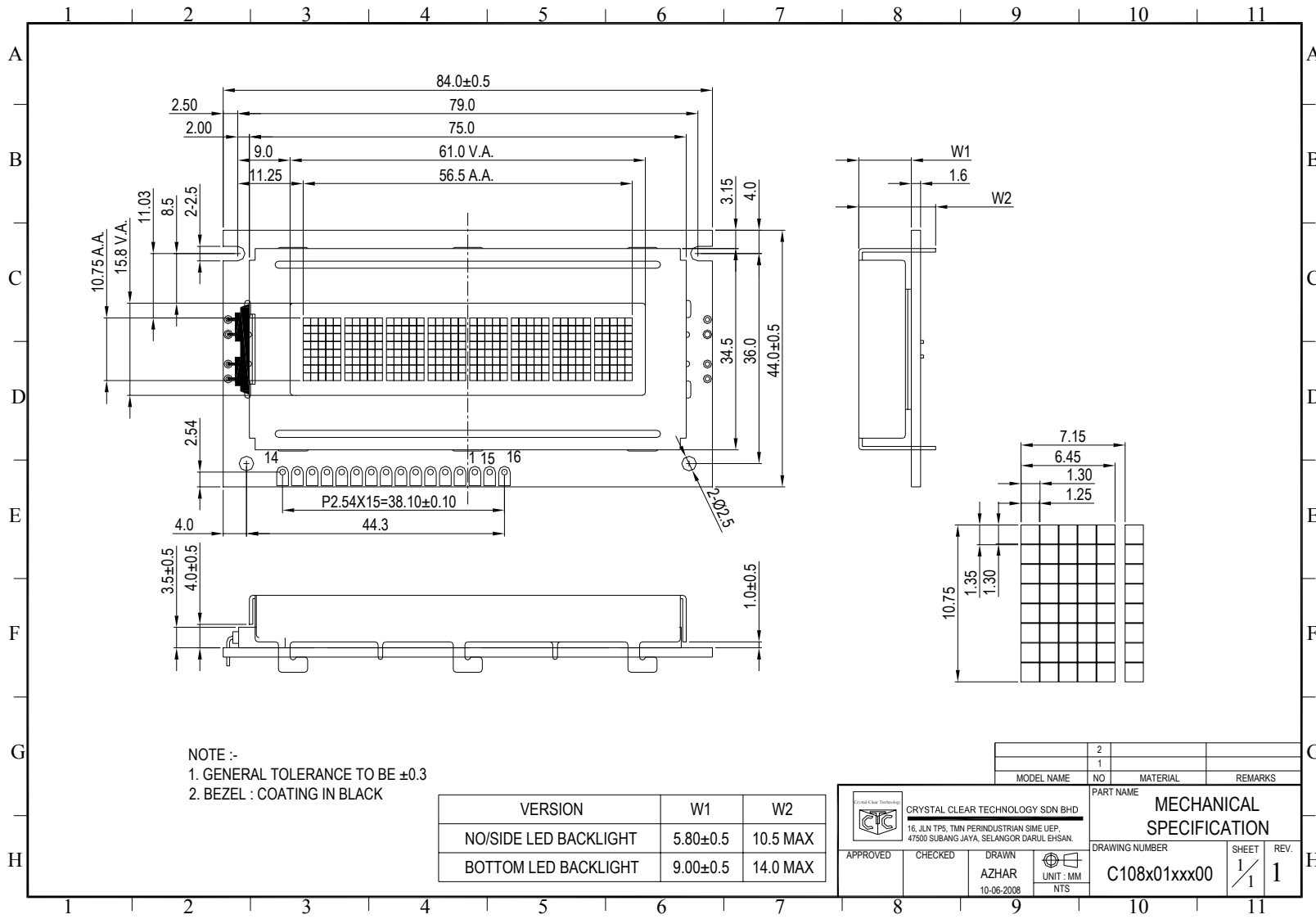



**Crystal Clear Technology**  
16 Jalan TP5—Taman Perindustrian Sime UEP  
47600 Subang Jaya—Selangor DE  
Malaysia