

Crystal Clear Technology

Product Specification

G2432W32xxxxx

(5.7 inch QVGA)

Without controller

Crystal Clear Technology sdn. bhd.

16Jalan TP5—Taman Perindustrian Sime UEP
47600 Subang Jaya—Selangor DE
Malaysia. T: +603 80247099 F: +603 80247098



1.0	Table of Contents	Page
1.	Table of Contents	1
2.	Record of revision	2
3.	General specification	3
4.	Absolute maximum ratings	4
5.	Electrical characteristics	4
6.	Environmental requirement	4
7.	LCD specification	5 ~ 7
8.	Interface	8
9.	Timing characteristics / Timing diagrams	9 ~ 12
10.	Power Supply	13
11.	Block Diagram	13
12.	Quality Assurance	14 ~ 16
13.	Precaution of Using LCM	17 ~ 18
14.	Outline Drawing	19



2.0 Record of revision

Rev	Date	Item	Page	Comment	Originator	Checked By
1.0	10/04/10			Initial Release	Khairiah	Azhar



3.0 General specification

Display format: Graphics, 240 (H) x 320 (W)

Pixel size: 0.33 (H) x 0.33 (W) mm

Pixel pitch: 0.36 (H) x 0.36 (W) mm

View area: 92.0 (H) x 122.0 (W) mm

Active area: 86.37 (H) x 115.17 (W) mm

General dimensions: 109.4 (H) x 160.4 (W) x 13.5 max (T) mm

Driver : NT7086 and NT7086 or equivalent

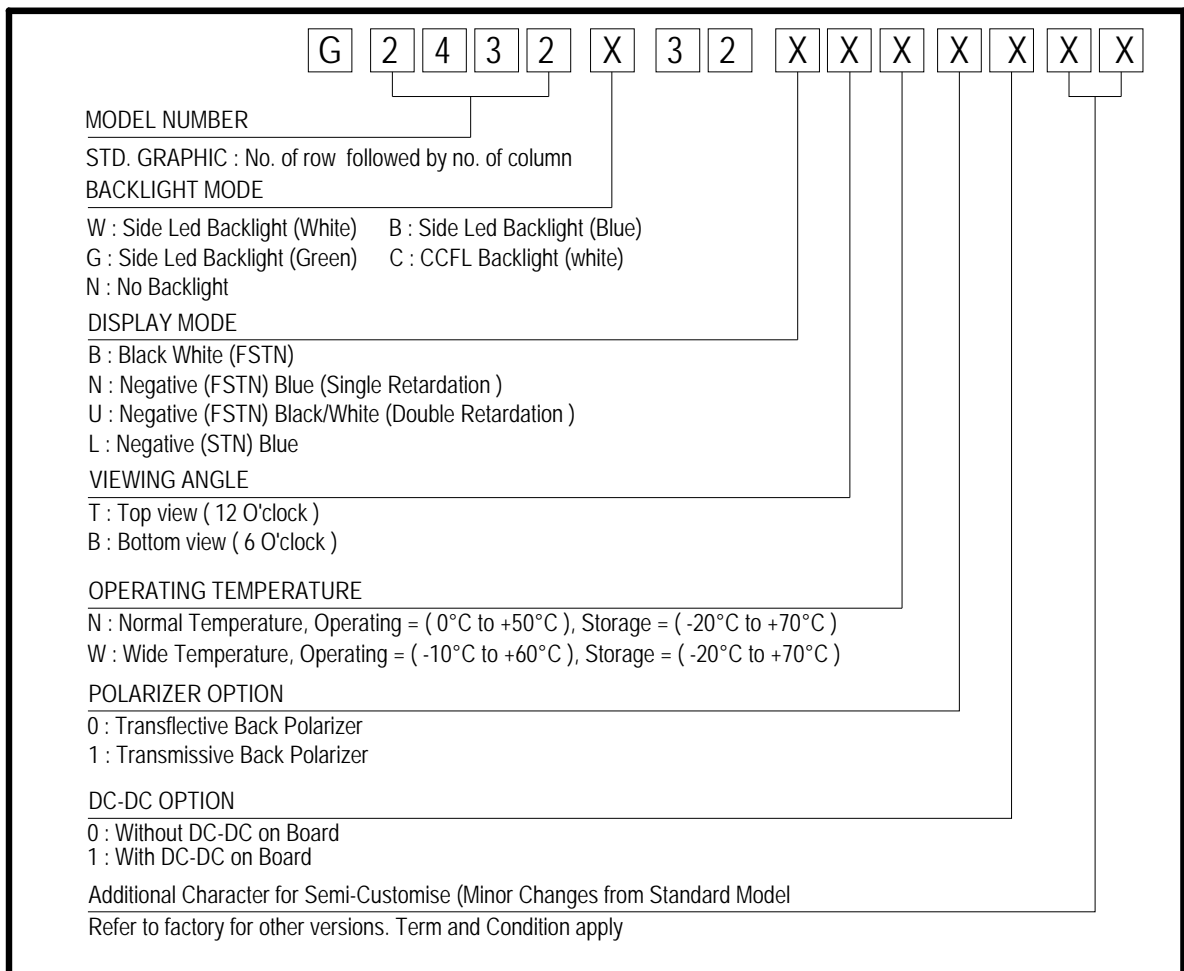

**4.0 Absolute maximum rating (at V_{SS} = 0V, ambient temperature = 25°C)**

NO	ITEM	SIMBOL	MIN	MAX	UNIT
1.	Power Supply voltage (Logic)	V _{DD} – V _{SS}	0	7.0	V
2.	Power Supply voltage (LCD Driver)	V _{DD} – V ₀	-	23.6	V
3.	Operating Temperature	T _{op}	Refer page 3		°C
4.	Storage Temperature	T _{st}	-20°C to +70°C		°C

5.0 Electrical characteristics

NO	ITEM	SYMBOL	CONDITION	MIN	TYP	MAX	UNIT
1.	Power Supply voltage (Logic)	V _{DD} – V _{SS}	-	4.5	5.0	5.5	V
2.	Power Supply voltage (V _{LCD})	V _{DD} -V ₀	25°C	20.0±5%			V
3.	Input Voltage	V _{IH}	-	0.9V _{DD}	-	V _{DD}	V
		V _{IL}	-	0	-	0.1V _{DD}	V
4	Current Supply	I _{DD}	V _{DD} – V _{SS} = 5V V _{DD} – V _{SS} = 30V		30.0	50.0	mA

5.1 Backlight Options LED.

NO	COLOR	FORWARD VOLTAGE (V)			FORWARD CURRENT (mA)			MIN BRIGHTNESS (cd/m ²) *
		Min	Typ.	Max	Min	Typ.	Max	
1.	White		5.0		-	150	200	400

- *Note :
- Brightness measured at backlight surface.
 - On LCD surface, brightness is only about 10% to 15% of backlight brightness.
 - Lifetime of backlight 20k hrs.

6.0 Environmental requirements

NO	ITEM	CONDITION
1.	Operating Temperature	Refer page 3
2.	Storage Temperature	-20°C to +70°C
3.	Operating Humidity	5% to 95%RH
4.	Cycle Test	0°C @ 30 min to 50°C @ 30min for 1 cycle run for 10 cycles
5.	Lifetime	50000 HOURS (excluding backlight)

Note:

- The background on LCD has the possibility to be changed in different temperature range.



7.0 LCD specification

7.1 Electro-optical characteristics (at ambient temperature = 25°C)

NO	ITEM	SYMBOL	CONDITION	LCD TYPE							REF.
				STN YG	STN GREY	STN -VE BLUE/ PURP LE	FSTN +VE B/W	FSTN -VE BLUE	FSTN - VE TRUE B/W	FSTN -VE TRI AXIS	
1	Operating Voltage (Volt)	V_{LCD}	$\theta = 0$ $Cr = \max$	20.0 ± 5%							7.1.1
2	Viewing Angle (Deg)	$\theta_x 1$	$CR \geq 2$ $V_{LCD} = 20.0V$	+20	+15	+35	+20	+35	+30	+40	7.1.2
		$\theta_x 2$		-20	-15	-35	-20	-35	-35	-40	
		$\theta_y 1$		-25	-20	-30	-25	-30	-30	-50	
		$\theta_y 2$		+25	+20	+30	+25	+30	+30	+30	
3	Contrast Ratio	CR	$\theta = 0^0$ $V_{LCD} = 20.0V$	2.5	2.0	5.5	2.5	5.5	15	15	7.1.3
4	Response Time (msec)	Rise Time (Tr)	$\theta = 0^0$	400							7.1.4
		Decay Time (Td)	$\theta = 0^0$	400							

Note:

1. Viewing angle data is based on bottom view product by default. Should it be a top view product, values are then swap.
2. Contrast ratio is based on typical data when using white colour as backlight.
3. Equipment Used Eldim; Ez Contrast 120R , Spot Size = 2mm

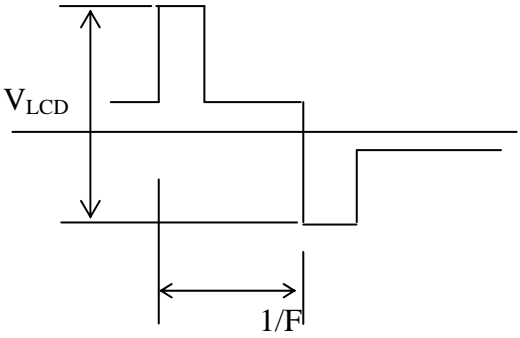
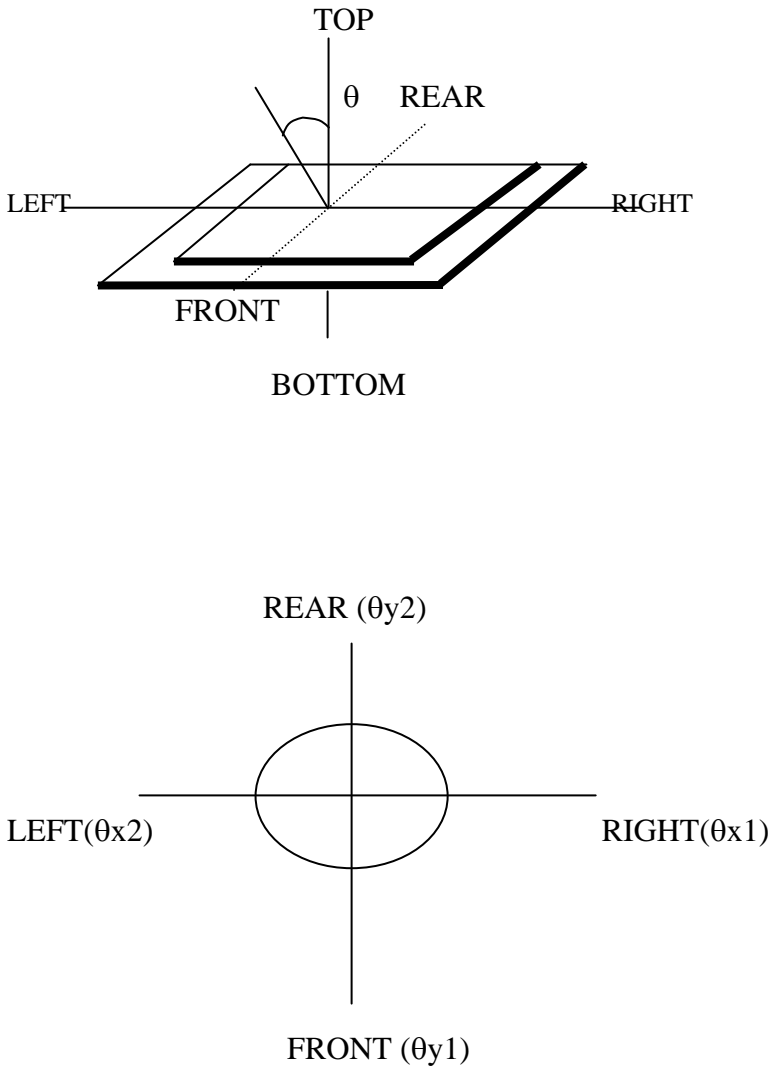

NO	CHARACTERISTICS	DEFINITIONS
7.1.1	<p>Definition of Operating Voltage (V_{LCD})</p>	 <p>V_{LCD} : Operating Voltage F : Frame Frequency</p>
7.1.2	<p>Definition of Viewing Angle</p>	 <p>Diagram illustrating the viewing angle θ relative to the normal (TOP) direction. The viewing angle is defined by the angle between the normal and the line of sight.</p> <p>Diagram illustrating the viewing angle ranges in the horizontal and vertical planes:</p> <ul style="list-style-type: none"> Horizontal viewing angle: θ_{x1} (RIGHT) and θ_{x2} (LEFT) Vertical viewing angle: θ_{y1} (FRONT) and θ_{y2} (REAR)

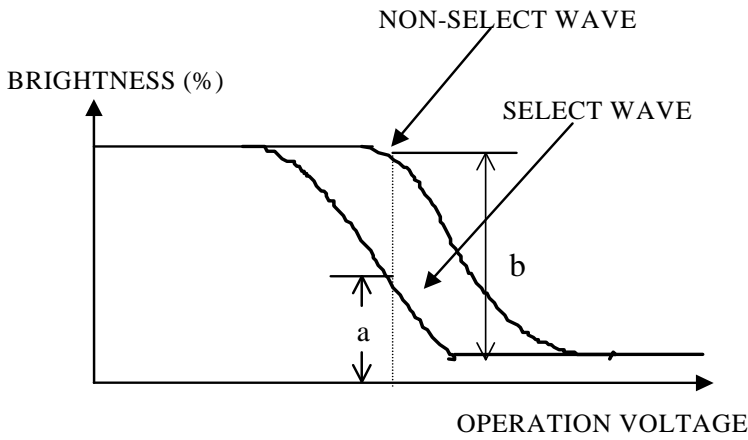
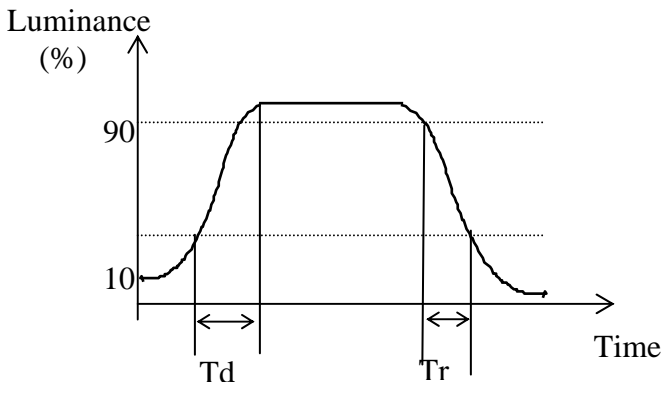

<p>7.1.3</p>	<p>Definition of Contrast Ratio</p>	 <p>Contrast Ratio = $\frac{\text{Brightness of non-selected state (b)}}{\text{Brightness of selected state (a)}}$</p> <p>Conditions</p> <ul style="list-style-type: none">(a) Operating Voltage: V_{LCD}(b) Temperature: $25^{\circ}C$(c) Viewing Angle, $\theta = 0^{\circ}$
<p>7.1.4</p>	<p>Response Time</p>	 <p>T_r: Measured between 10% and 90% of LCD segment maximum response with V_{ON}.</p> <p>T_d: With voltage switches to zero and the instant LCD segment reaches 10% of its maximum response.</p>

**8.0 Interface**

8.1	Display Controller	-
8.2	Display driver	S6B2086
8.3	Cycle duty	1/240
8.4	Pin-out Assignments	
CONNECTOR (CNI)		
Pin No	Symbol	Function
1	XD1	Display data
2	XD2	
3	XD3	
4	XD4	
5	YDIS	Display off signal
6	YD	Frame Signal
7	WF	LCD drive output AC Signal
8	LP	Latch pulse for column driver. Shift clock for row driver. (Data latch)
9	XSCL	X-driver shift clock. (Data shift)
10	VDD	Supply terminal of module
11	VSS	Ground terminal of module
12	VEE	Negative supply for Liquid Crystal Drive
13	V0	Liquid Crystal Display contrast adjust
14	VBL+	Supply terminal of backlight



9.0 Timing Diagram For LCD Driver.

9.1 System Bus (Generic Bus/80-series MPU)

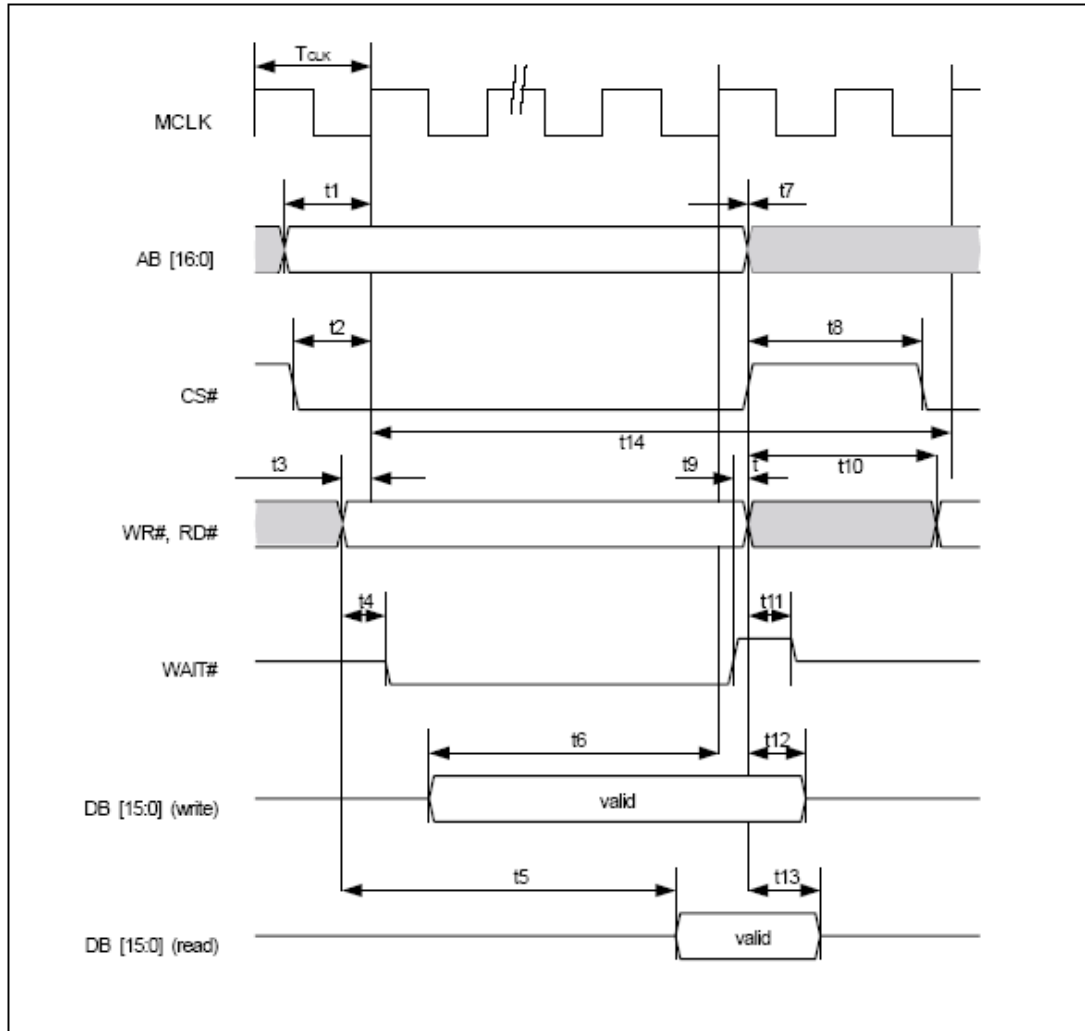

* MCLK denotes CLKI or the internally generated system clock.



Generic Bus Interface Timing

[V_{SS} = 0V, V_{DD} = 4.5 – 5.5V, Ta = -40 – 85°C]

Symbol	Parameter	Spec		Unit
		Min.	Max.	
f _{CLK}	BUS clock frequency	—	64	MHz
T _{CLK}	BUS clock period	1/f _{CLK}	—	ns
t1	AB [16 : 0] setup to first CLK rising edge where CS# = 0 and either RD# = 0 or WR# = 0	11	—	ns
t2	CS# setup to CLK rising edge	9	—	ns
t3	RD#, WR# setup to CLK rising edge	9	—	ns
t4	RD#, WR# state change to WAIT# driven low	1	5	ns
t5	RD# falling edge to DB [15 : 0] driven (ead cycle)	3Tc+9ns	—	Tclk
t6	DB [15 : 0] setup to 4th rising CLK edge after CS# = 0 and WR# = 0	1	—	T _{CLK}
t7	AB [16 : 0], CS# hold from RD#, WR# rising edge	8	—	ns
t8	CS# deasserted to reasserted - When read - when Write (next cycle = write cycle) - when Write (next cycle = read cycle)	1Tclk 2Tclk+8ns 5Tclk+8ns	—	ns ns ns
t9	WAIT# rising edge to RD#, WR# rising edge	0	—	ns
t10	WR#, RD# deasserted to reasserted - When read - when Write (next cycle = write cycle) - when Write (next cycle = read cycle)	1Tclk 2Tclk+8ns 5Tclk+8ns	—	ns ns ns
t11	Rising edge of either RD# or WR# to WAIT# high impedance 0.5 TCLK	—	0.5	T _{CLK}
t12	D [15 : 0] hold from WR# rising edge (write cycle)	1	—	ns
t13	D [15 : 0] hold from RD# rising edge (read cycle)	1	—	ns
t14	Cycle Length Read Write (next write cycle) Write (next read cycle)	6 7 10	—	T _{CLK}



9.2 System Bus Read/Write characteristics (MC68K-series MPU)

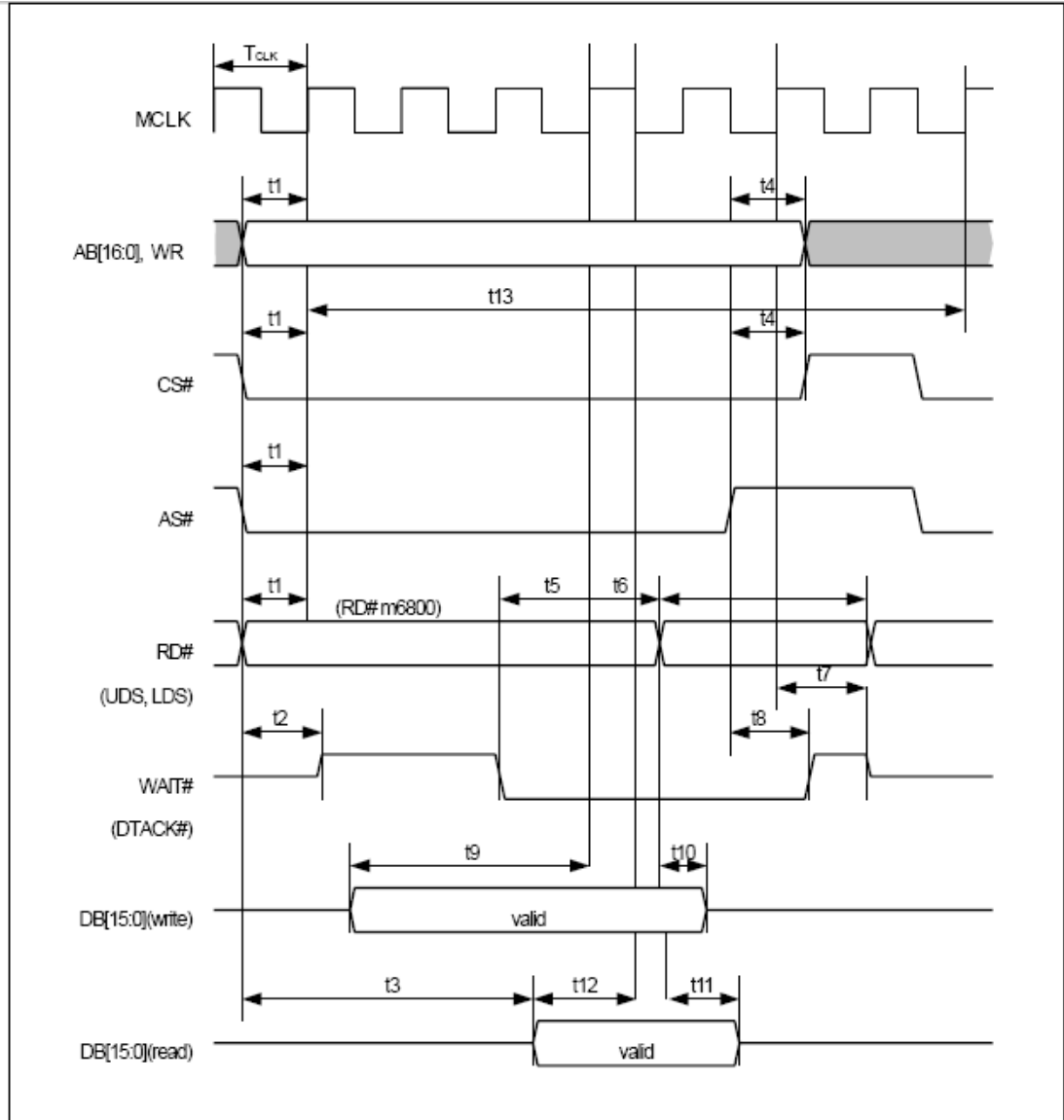

* MCLK denotes CLKI or the internally generated system clock.



9.3 LCD Control Signal Timing Characteristics

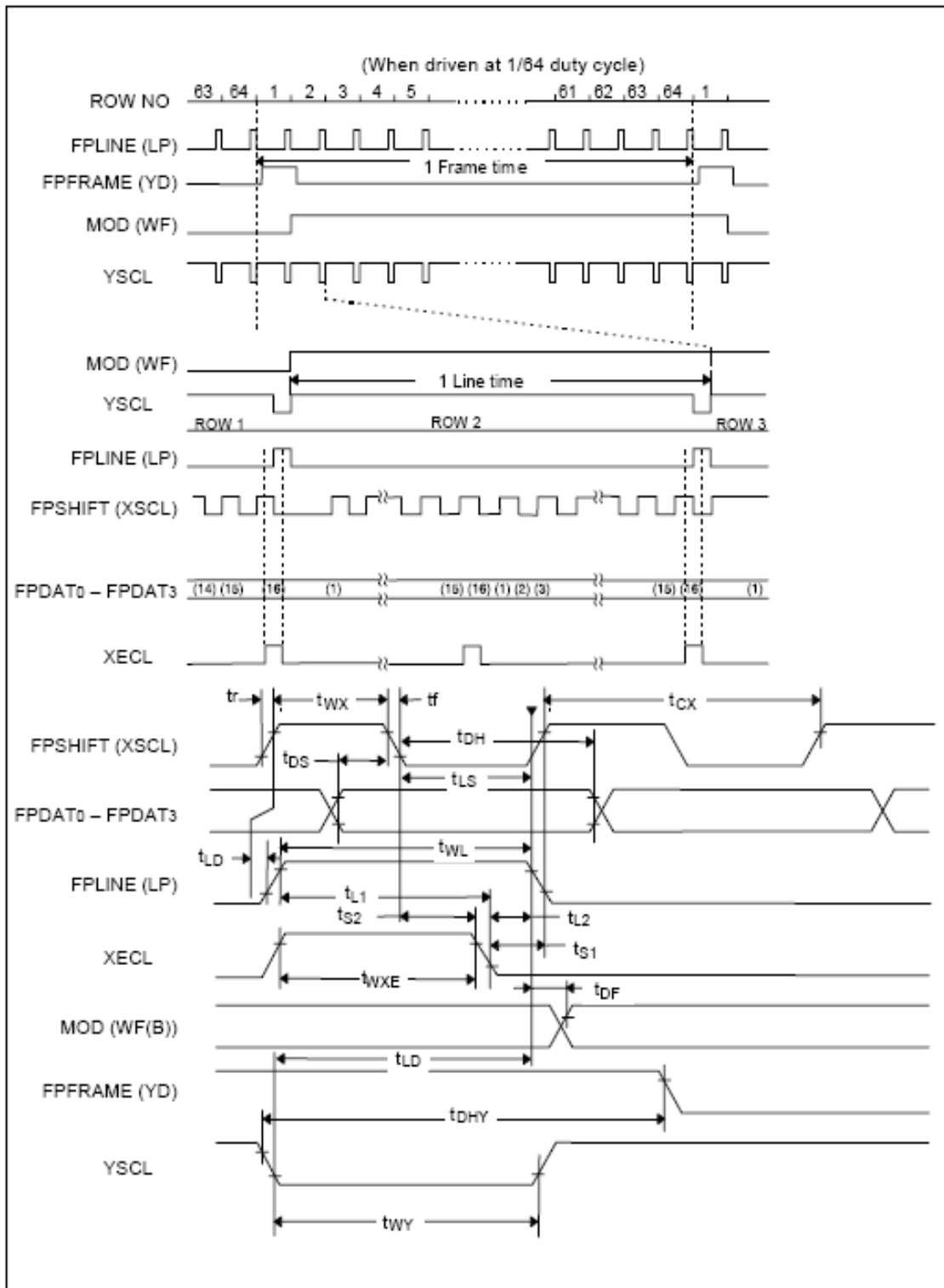



10. Power Supply

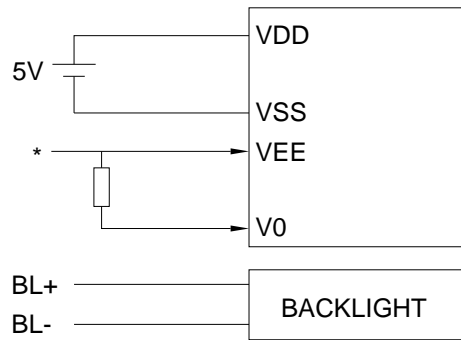

*WITH BUILT IN DC-DC
- VEE SUPPLIED BY INTERNAL DC-DC

*WITHOUT DC-DC BUILT IN
- CUSTOMER NEED TO SUPPLY EXTERNAL VEE

11. Block Diagram

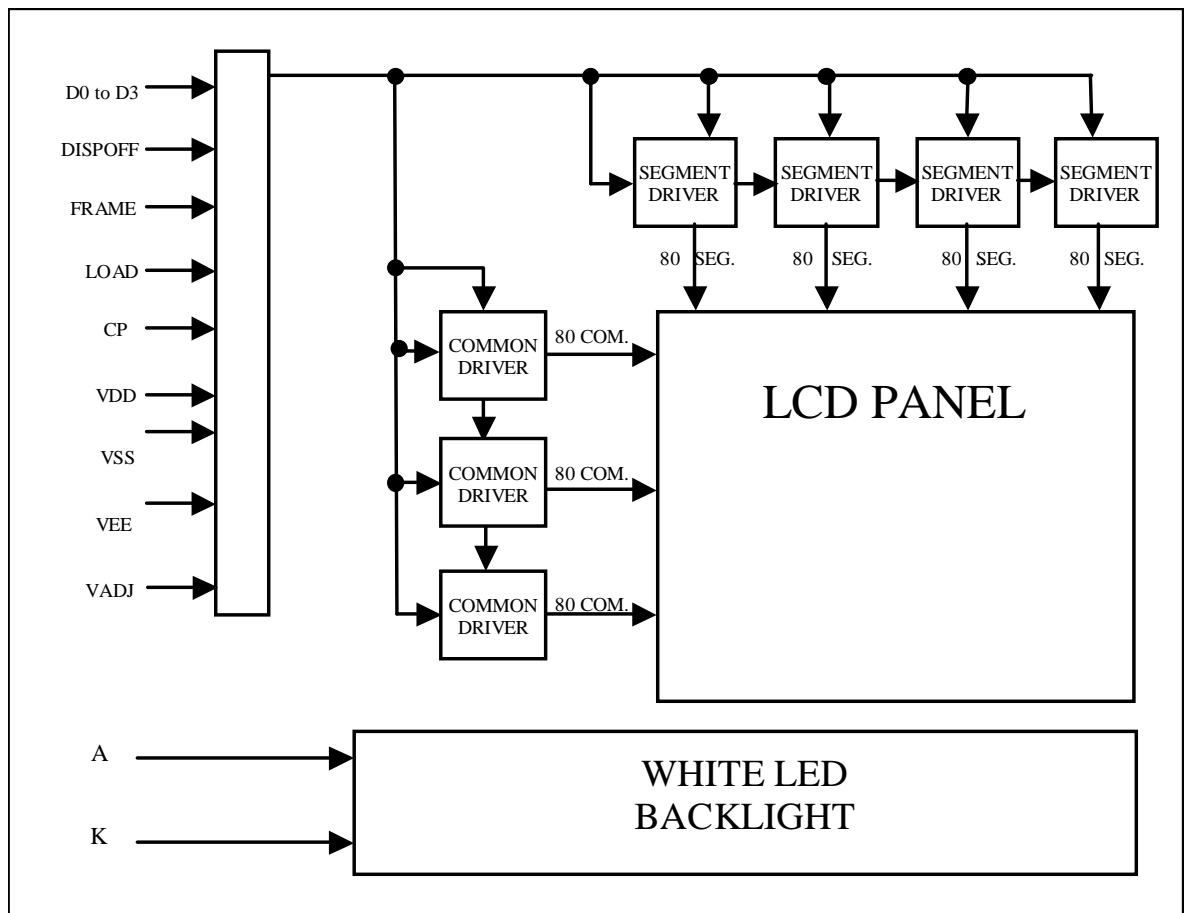



12. Quality Assurance

1. CRITERIA INVOLVED:

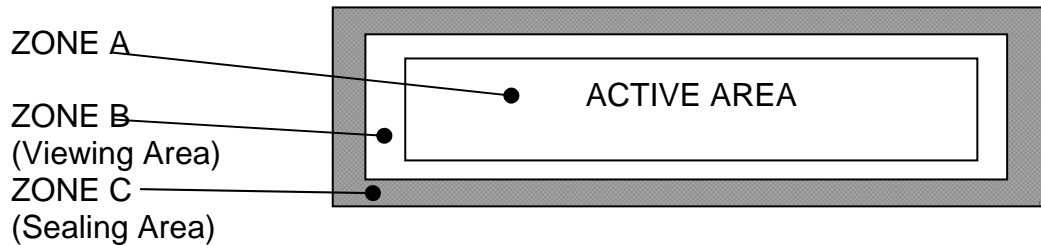

- No. ITEM
 1.1 Black Spot, Foreign Materials,
 White Spot, Polarizer Damage

CRITERIA
 Round Shape (solid figure)

Mean diameter = X (Long axis + short axis) /2	Maximum Acceptance Numbers		
	Zone A	Zone B	Zone C
$X \leq 0.10$	Disregard	Disregard	Disregard
$0.10 < X \leq 0.15$	3	3	
$0.15 < X \leq 0.25$	1	2	
$0.25 < X \leq 0.35$	1	1	
$X > 0.35$	0	0	

*The 1/3 or larger parts of individual dot has to be lighted on. The solid figure is that the defect has clear-cut outline at the optimum driving condition In both positive and negative, of which size does not change when the contrast changes.

Mean diameter = X (Long axis + short axis) /2	Maximum Acceptance Numbers		
	Zone A	Zone B	Zone C
$X \leq 0.60$	Disregard	Disregard	Disregard
$0.60 < X \leq 0.70$	3		
$0.70 < X \leq 0.80$	1		
$X > 0.80$	0		

* The faded figure means that the defects has unclear outline at the optimum driving condition in both positive and negative, of which size seems to change when the contrast changes.



3) Linear (Fibrous)

Size		Maximum Acceptable No.		
Length	Width	Zone A	Zone B	Zone C
Disregard	≤ 0.03mm	Disregard		Disregard
≤ 2mm	≤ 0.05mm	3		
≤ 1mm	≤ 0.10mm			
-----	> 0.10mm	Due to (1) round defect		

* Length is the whole length and width the maximum width of foreign material.

Total amount of spotting defects including round and linear:-
5 are the totally permissible numbers of defects in Zone A & B including above (1), (2), (3). In case of the total permissible, the minimum distance has to be 5mm or larger between every couple of defects.

APPENDIX II

NO	ITEM
1.2	Pin Hole

	<p>Maximum acceptance numbers: 1 per dot 3 per display area (active area)</p>
	<p>Maximum acceptance numbers: 1 per dot 3 per display area (active area)</p> <p><i>¾ or larger part of dot area has to be effective for display.</i></p>

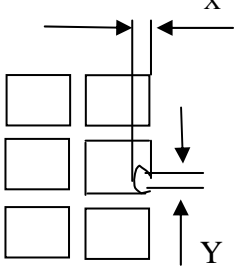
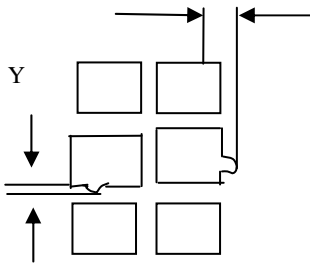

1.3 Deformed display dot

<p>1) Lacked deformation</p> 	<p>$0.15 \geq X$ $0.15 \geq Y$</p>
<p>2) Added deformation</p> 	<p>$0.02 > X$ $0.02 > Y$</p>

1.4 Polarizer Air Bubbles

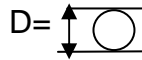

Size	Maximum Acceptable No.		
	Zone A	Zone B	Zone C
$D \leq 0.30\text{mm}$	Disregard	Disregard	Disregard if the polarizer not lifted up pealed off
$D \leq 0.50\text{mm}$	2		
$0.50 < D \leq 0.60\text{mm}$	1	2	
$D > 0.60\text{mm}$	0		
Total amount of bubbles	3 are the totally permissible numbers of bubble		

REMARK

All the other items of inspection that are not included herein must be determined by the "Limit Standard" sample, which were occasionally set up with the mutual consent of both parties. In every case of the items setup with the Limit Standard, the Limit Standard always takes precedence over the other means of definition.



13. Precaution for using LCM

1. Liquid Crystal Display (LCD)

LCD is made up of glass, organic sealant, organic fluid and polymer based polarizers. The following precautions should be taken when handling.

- b) Keep the temperature within the range of use and storage. Excessive temperature and humidity could cause polarization degradation, polarizer peel off or bubble.
- c) Do not contact the exposed polarizer with anything harder than HB pencil lead. To clean dust off the display surface, wipe gently with cotton, chamois or other soft material soaked in petroleum benzine.
- d) Wipe off saliva or water drops immediately. Contact with water over a long period of time may cause polarizer deformation or colour fading, while an active LCD with water condensation on its surface will cause corrosion of ITO electrodes.
- e) Glass can be easily chipped or cracked from rough handling, especially at corners and edges.
- f) Do not drive LCD with DC voltage.

2. Liquid Crystal Display Modules.

2.1 Mechanical Considerations

LCM are assembled and adjusted with a high degree of precision. Avoid excessive shocks and do not make any alterations or modification. The following should be noted.

- a) Do not tamper in any way with the tabs on the metal frame.
- b) Do not modify the PCB by drilling extra holes, changing its outline, moving its component or modifying its pattern.
- c) Do not touch the elastomer connector, especially insert a backlight panel (for example, EL)
- d) When mounting a LCM make sure that the PCB is not under any stress such as bending or twisting. Elastomer contacts are very delicate and missing pixels could result from slight dislocation of any of the elements.

- a) Avoid pressing on the metal bezel, otherwise the elastomer connector could be deformed and lose contact, resulting in missing pixels.

2.2 Static Electricity

LCM contains CMOS LSI's and the same precaution for such devices should apply, namely

- a) The operator should be grounded whenever he/she comes into contact with the module. Never touch any of the conductive parts such as the LSI pads, the copper leads on the PCB and the interface terminals with any parts of the human body.
- b) The modules should be kept in antistatic bags or other containers to static for storage.
- c) Only properly grounded soldering irons should be used.
- d) If an electric screwdriver is used, it should be well grounded and shielded from commutator spark.
- e) The normal static prevention measures should be observed for work clothes and working benches, the latter conductive (rubber) mat is recommended.
- f) Since dry air is inductive to statics, a relative humidity of 50-60% is recommended.

2.3 Soldering

- a) Solder only to the I/O terminals.
- b) Use only soldering irons with proper grounding and no leakage.
- c) Soldering temperature: 280°C
- d) Soldering time: 3 to 4 sec
- e) Use eutectic solder with resin flux fill.
- f) If flux is used, the LCD surface should be covered to avoid flux spatters. Flux residue should be removed afterwards.



2.4 Operation

- a) The contrast can be adjusted by varying the LCD driving voltage V_0
- b) Driving voltage should be kept within specified range, excess voltage shortens display life.
- c) Response time increases with decrease in temperature.
- d) Display may turn black or dark blue at temperature above its operational range, this is (however not pressing on the viewing area) may cause the segments to appear “fractured”.
- e) Mechanical disturbance during operation (such as pressing on the viewing area) may cause the segments to appear “fractured”.

2.5 Storage

If any fluid leaks out of the damaged glass cell, wash off any human part that comes into contact with soap and water. Never swallow the fluid. The toxicity is extremely low but caution should be exercised at all the time.

2.6 Limited Warranty

Unless otherwise agreed between Crystal Clear Technology and customer, Crystal Clear Technology will replace or repair any of its LCD and LCM which is found to be defective electrically and visually when inspected in accordance with Crystal Clear Technology acceptance standards, for a period of one year from date of shipment. Confirmation of such date shall be based on freight documents. The warranty liability of Crystal Clear Technology is limited to repair and/or replacement on the terms set forth above. Crystal Clear Technology will not be responsible for any subsequent or consequential events.

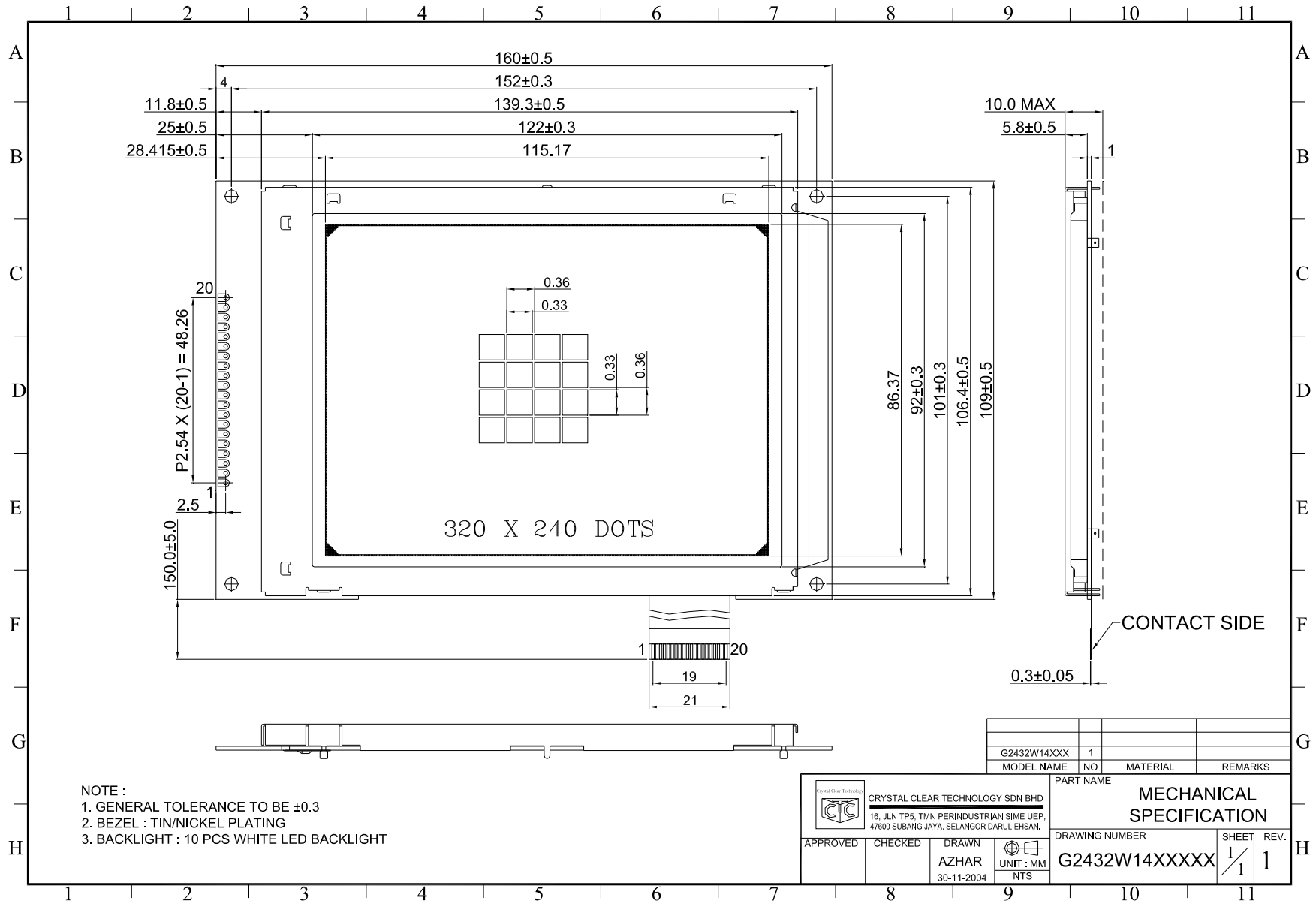



Crystal Clear Technology
16 Jalan TP5—Taman Perindustrian Sime UEP
47600 Subang Jaya—Selangor DE
Malaysia