

Crystal Clear Technology

Product Specification

G128240x05 series

Crystal Clear Technology sdn. bhd.

16Jalan TP5—Taman Perindustrian Sime UEP
47600 Subang Jaya—Selangor DE
Malaysia. T: +603 80247099 F: +603 80247098



1.0 Table of Contents

	Page
1. Table of Contents	1
2. Record of revision	2
3. General specification	3
4. Absolute maximum ratings	4
5. Electrical characteristics	4
6. Environmental requirement	4
7. LCD specification	5 ~ 7
8. Interface	8
9. Timing characteristics / Timing diagrams	9 ~ 10
10. Command Summary	11
11. Block Diagram and Power Supply	12
12. Quality assurance	13 ~ 20
13. Precautions in use LCM	21 ~ 22
14. Outline drawing	23



2.0 Record of revision

Rev	Date	Item	Page	Comment	Originator	Checked By
1.0	30/09/08			Initial Release	Syam	Azhar
2.0	10.09.09			Update mechanical specification	Khairiah	Azhar



3.0 General specification

Display format: Graphics, 240 (H) x 128 (W)

Pixel size: 0.40 (H) x 0.40 (W) mm

Pixel pitch: 0.45 (H) x 0.45 (W) mm

View area: 64.0 (H) x 114.0 (W) mm

Active area: 57.55 (H) x 107.95 (W) mm

General dimensions: 104.0 (H) x 144.0 (W) x 13.5 max (T) mm

Controller/Driver: T6963 and NT7086 or equivalent

Interface: Parallel

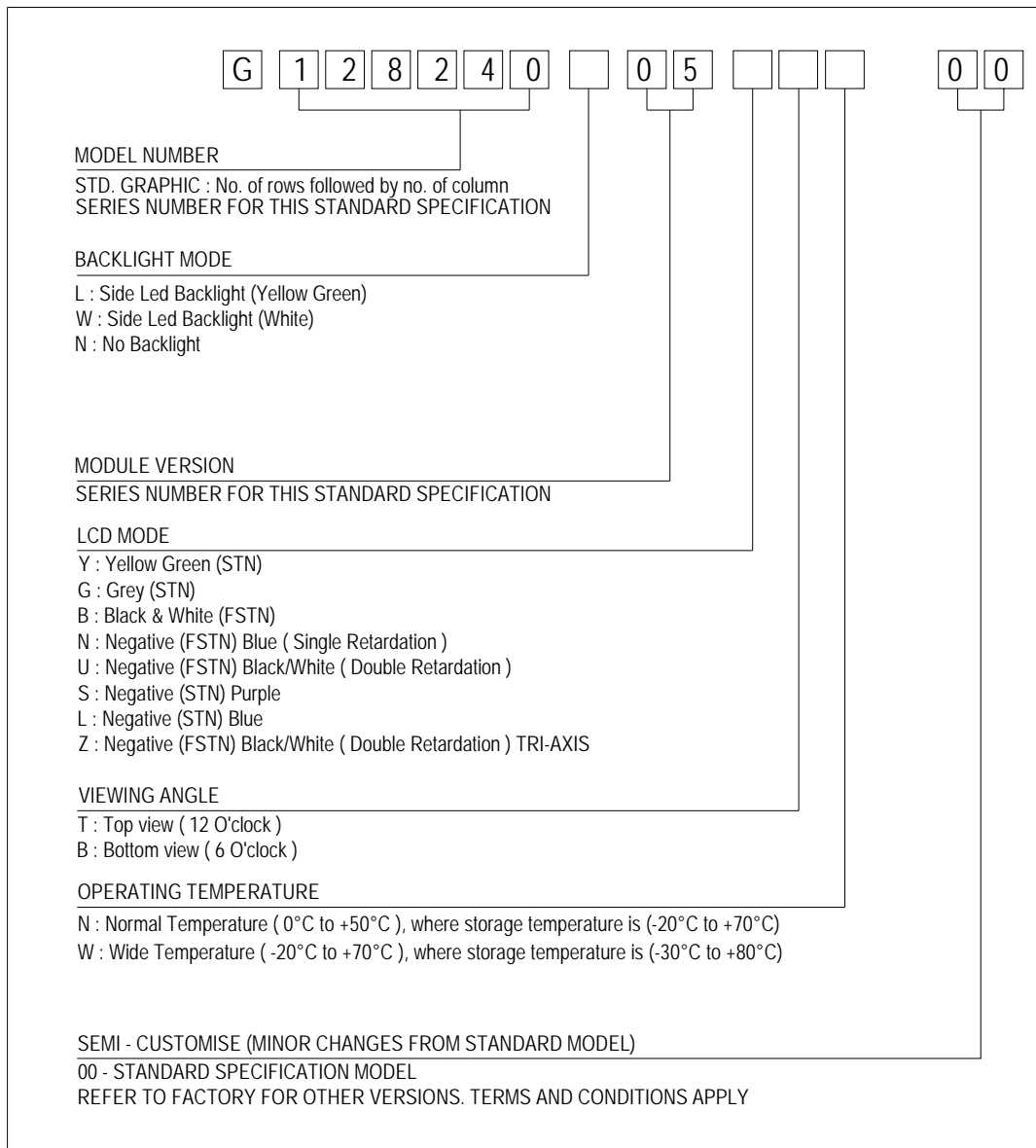

4.0 Absolute maximum rating (at $V_{SS} = 0V$, ambient temperature = 25°C)

NO	ITEM	SIMBOL	MIN	MAX	UNIT
1.	Power Supply voltage (Logic)	$V_{DD} - V_{SS}$	0	7.0	V
2.	Power Supply voltage (LCD Driver)	$V_{DD} - V_0$	-	19.0	V
3.	Operating Temperature	T_{op}	Refer page 3		°C
4.	Storage Temperature	T_{st}	Refer page 3		°C

5.0 Electrical characteristics

NO	ITEM	SYMBOL	CONDITION	MIN	TYP	MAX	UNIT
1.	Power Supply voltage (Logic)	$V_{DD} - V_{SS}$	-	4.5	5.0	5.5	V
2.	Power Supply voltage (V_{LCD})	$V_{DD} - V_0$	25°C	17.5±5%			V
3.	Input Voltage	V_{IH}	-	$V_{DD} - 0.2$	-	V_{DD}	V
		V_{IL}	-	0	-	0.8	V
4.	Current Supply	I_{DD}	$V_{DD} - V_{SS} = 5.0V$	-	17	20	mA

5.1 Backlight Options

NO	COLOR	FORWARD VOLTAGE (V)			FORWARD CURRENT (mA)			MIN BRIGHTNESS (cd/m ²) *
		Min	Typ.	Max	Min	Typ.	Max	
1.	Yellow Green	-	4.5	-	-	180	220	30
2.	White	-	5.0	-	-	120	160	110

- *Note :
- Brightness measured at backlight surface.
 - On LCD surface, brightness is only about 10% to 15% of backlight brightness.
 - Lifetime of backlight: For Yellow Green = 50K hrs. For White = 20k hrs.

6.0 Environmental requirements

NO	ITEM	CONDITION
1.	Operating Temperature	Refer page 3
2.	Storage Temperature	Refer page 3
3.	Operating Humidity	5% to 95%RH
4.	Cycle Test	0 C @ 30 min to 50 C @ 30min for 1 cycle run for 10 cycles
5.	Lifetime	50000 HOURS (excluding backlight)

Note: The background on LCD has the possibility to be changed in different temperature range.



7.0 LCD specification

7.1 Electro-optical characteristics (at ambient temperature = 25°C)

NO	ITEM	SYMBOL	CONDITION	LCD TYPE							REF.
				STN YG	STN GREY	STN -VE BLUE/PURPLE	FSTN +VE B/W	FSTN -VE BLUE	FSTN -VE TRUE B/W	FSTN -VE TRI AXIS	
1	Operating Voltage (Volt)	V_{LCD}	$\theta = 0$ $Cr = \max$	17.5 ± 5%							7.1.1
2	Viewing Angle (Deg)	$\theta_x 1$	$CR \geq 2$ $V_{LCD} = 14.7V$	+20	+15	+35	+20	+35	+30	+40	7.1.2
		$\theta_x 2$		-20	-15	-35	-20	-35	-35	-40	
		$\theta_y 1$		-25	-20	-30	-25	-30	-30	-50	
		$\theta_y 2$		+25	+20	+30	+25	+30	+30	+30	
3	Contrast Ratio	CR	$\theta = 0^0$ $V_{LCD} = 14.7V$	2.5	2.0	5.5	2.5	5.5	15	15	7.1.3
4	Response Time (msec)	Rise Time (Tr)	$\theta = 0^0$	400							7.1.4
		Decay Time (Td)	$\theta = 0^0$	400							

Note:

1. Viewing angle data is based on bottom view product by default. Should it be a top view product, values are then swap.
2. Contrast ratio is based on typical data when using white colour as backlight.
3. Equipment Used Eldim; Ez Contrast 120R , Spot Size = 2mm

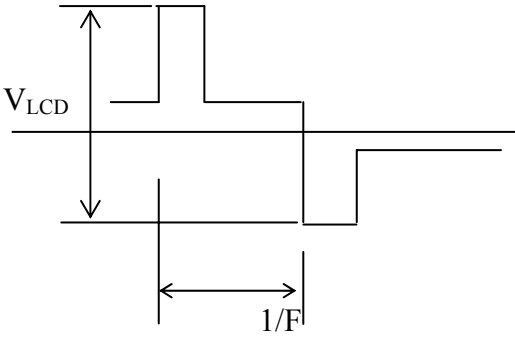
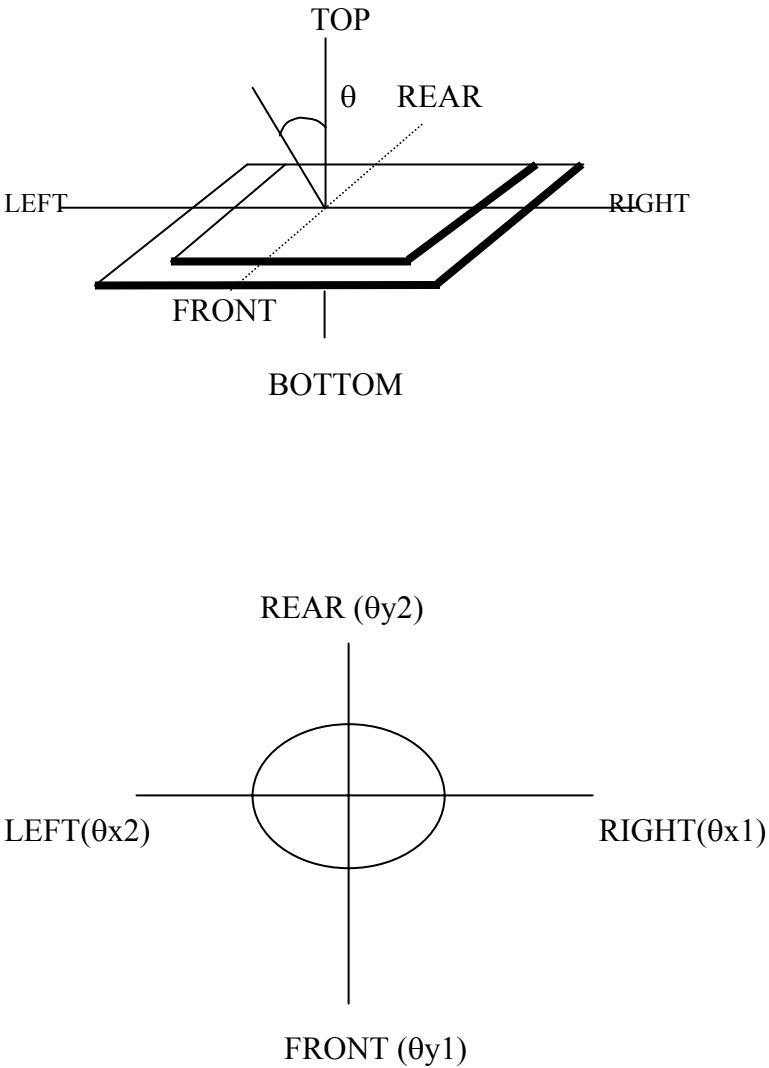

NO	CHARACTERISTICS	DEFINITIONS
7.1.1	<p>Definition of Operating Voltage (V_{LCD})</p>	 <p>V_{LCD} : Operating Voltage F : Frame Frequency</p>
7.1.2	<p>Definition of Viewing Angle</p>	

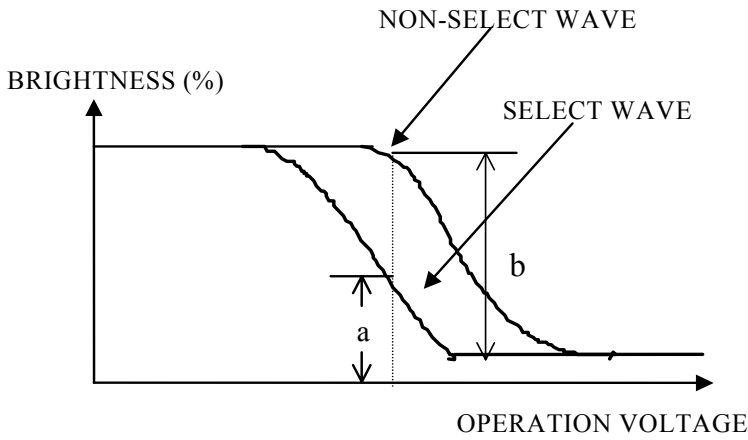
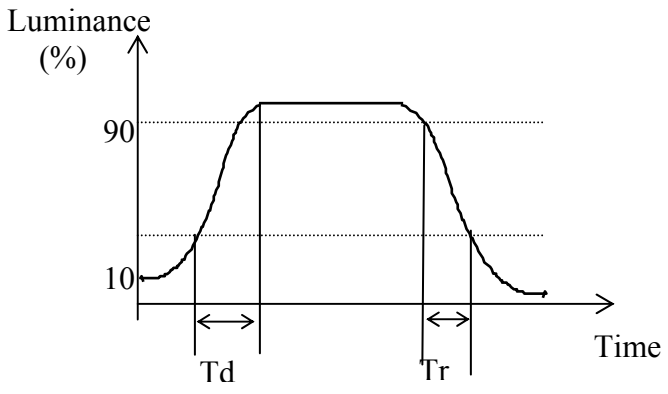

<p>7.1.3</p>	<p>Definition of Contrast Ratio</p>	 <p>Contrast Ratio = $\frac{\text{Brightness of non-selected state (b)}}{\text{Brightness of selected state (a)}}$</p> <p>Conditions</p> <ul style="list-style-type: none">(a) Operating Voltage: V_{LCD}(b) Temperature: $25^{\circ}C$(c) Viewing Angle, $\theta = 0^{\circ}$
<p>7.1.4</p>	<p>Response Time</p>	 <p>T_r: Measured between 10% and 90% of LCD segment maximum response with V_{ON}.</p> <p>T_d: With voltage switches to zero and the instant LCD segment reaches 10% of its maximum response.</p>



8.0 Interface

8.1	<i>Controller</i>	T6963C	
8.2	<i>Display Driver</i>	NT7086 or equivalent	
8.3	<i>Duty Cycle</i>	1/128	
8.4	<i>Pin-out Assignments</i>		
	Pin No	Symbol	Description
	1	V _{SS}	Ground Terminal of Module
	2	V _{DD}	Supply terminal of Module
	3	V ₀	Power supply for Liquid Crystal Drive
	4	C/D	Command/Data High = Command Register Low = Data Register
	5	/RD	Read Signal (active low)
	6	/WR	Write Signal (active low)
	7	DB0	Data Bus
	8	DB1	Data Bus
	9	DB2	Data Bus
	10	DB3	Data Bus
	11	DB4	Data Bus
	12	DB5	Data Bus
	13	DB6	Data Bus
	14	DB7	Data Bus
	15	/CE	Chip Enable Signal
	16	/RESET	Reset signal (active Low)
	17	VEE	Negative Voltage
	18	MD2	Control signal
	19	FS1	Font Selection (please refer to table below)
	20	NC	Not connected
	21	BL+	Backlight Voltage supply
	22	BL-	Backlight Ground terminal

***Font interface format selection :**

Font size	J1	J2	Pin FS1
5x8	Used	NC	High
6x8	NC*	Used*	High
7x8	Used	NC	Low
8x8	NC*	Used*	Low

Note: NC = Not Connected, * = Factory default settings.



9.0 Timing characteristics / Timing diagrams

9.1 Display Control Timing Waveform and Characteristics

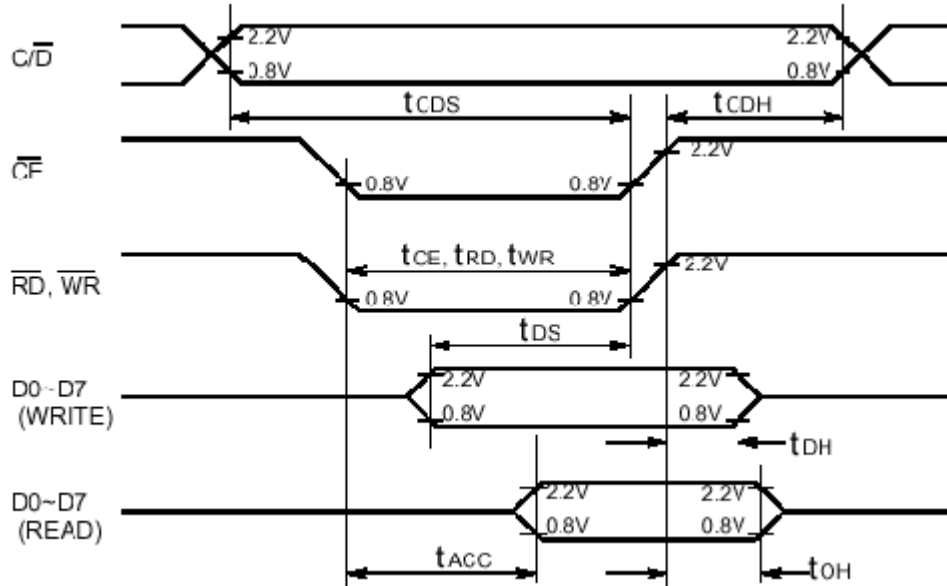

Item	Symbol	Min	Typ	Max	Unit
C/D Set Up Time	t_{CDS}	100	-	-	ns
C/D Hold Time	t_{CDH}	10	-	-	ns
CE, RD, WR Pulse Width	t_{CE}, t_{RD}, t_{WR}	80	-	-	ns
Data Set Up Time	t_{DS}	80	-	-	ns
Data Hold Time	t_{DH}	40	-	-	ns
Access time	t_{ACC}	-	-	150	ns
Output Hold Time	t_{OH}	10	-	50	ns

Timing Characteristics between MPU and T6963



9.2 Relationship between character code and pattern

CG ROM TYPE 0101

MSB	LSB	0	1	2	3	4	5	6	7	8	9	A	B	C	D	E	F
0		!	"	#	\$	%	&	'	()	*	+	,	-	.	/	
1		0	1	2	3	4	5	6	7	8	9	:	;	<	=	>	?
2		@	A	B	C	D	E	F	G	H	I	J	K	L	M	N	O
3		P	Q	R	S	T	U	V	W	X	Y	Z	[\]	^	_
4		~	a	b	c	d	e	f	g	h	i	j	k	l	m	n	o
5		p	q	r	s	t	u	v	w	x	y	z	{		}	~	
6		0	1	2	3	4	5	6	7	8	9	:	;	<	=	>	?
7		@	A	B	C	D	E	F	G	H	I	J	K	L	M	N	O

CG ROM TYPE 0201

MSB	LSB	0	1	2	3	4	5	6	7	8	9	A	B	C	D	E	F
0		!	"	#	\$	%	&	'	()	*	+	,	-	.	/	
1		0	1	2	3	4	5	6	7	8	9	:	;	<	=	>	?
2		@	A	B	C	D	E	F	G	H	I	J	K	L	M	N	O
3		P	Q	R	S	T	U	V	W	X	Y	Z	[\]	^	_
4		~	a	b	c	d	e	f	g	h	i	j	k	l	m	n	o
5		p	q	r	s	t	u	v	w	x	y	z	{		}	~	
6		0	1	2	3	4	5	6	7	8	9	:	;	<	=	>	?
7		@	A	B	C	D	E	F	G	H	I	J	K	L	M	N	O



10. Instruction Set

COMMAND	CODE	D1	D2	FUNCTION
REGISTER SETTING	00100001	X address	Y address	Set Cursor Pointer
	00100010	Data	00H	Set Offset Register
	00100100	Low address	High address	Set Address Pointer
SET CONTROL WORD	01000000	Low address	High address	Set Text Home Address
	01000001	Columns	00H	Set Text Area
	01000010	Low address	High address	Set Graphic Home Address
	01000011	Columns	00H	Set Graphic Area
MODE SET	1000X000	-	-	OR mode
	1000X001	-	-	EXOR mode
	1000X011	-	-	AND mode
	1000X100	-	-	Text Attribute mode
	10000XXX	-	-	Internal CG ROM mode
	10001XXX	-	-	External CG RAM mode
DISPLAY MODE	10010000	-	-	Display off
	1001XX10	-	-	Cursor on, blink off
	1001XX11	-	-	Cursor on, blink on
	100101XX	-	-	Text on, graphic off
	100110XX	-	-	Text off, graphic on
	100111XX	-	-	Text on, graphic on
CURSOR PATTERN SELECT	10100000	-	-	1-line cursor
	10100001	-	-	2-line cursor
	10100010	-	-	3-line cursor
	10100011	-	-	4-line cursor
	10100100	-	-	5-line cursor
	10100101	-	-	6-line cursor
	10100110	-	-	7-line cursor
	10100111	-	-	8-line cursor
DATA AUTO READ / WRITE	10110000	-	-	Set Data Auto Write
	10110001	-	-	Set Data Auto Read
	10110010	-	-	Auto Reset
DATA READ / WRITE	11000000	Data	-	Data Write and Increment ADP
	11000001	-	-	Data Read and Increment ADP
	11000010	Data	-	Data Write and Decrement ADP
	11000011	-	-	Data Read and Decrement ADP
	11000100	Data	-	Data Write and Nonvariable ADP
	11000101	-	-	Data Read and Nonvariable ADP
SCREEN PEEK	11100000	-	-	Screen Peek
SCREEN COPY	11101000			Screen Copy
BIT SET / RESET	11110XXX	-	-	Bit Reset
	11111XXX	-	-	Bit set
	1111X000	-	-	Bit 0 (LSB)
	1111X001	-	-	Bit 1
	1111X010	-	-	Bit 2
	1111X011	--	--	Bit 3
	1111X100	-	-	Bit 4
	1111X101	-	-	Bit 5
	1111X110	-	-	Bit 6
	1111X111	-	-	Bit 7 (MSB)



11. Block Diagram and Power Supply

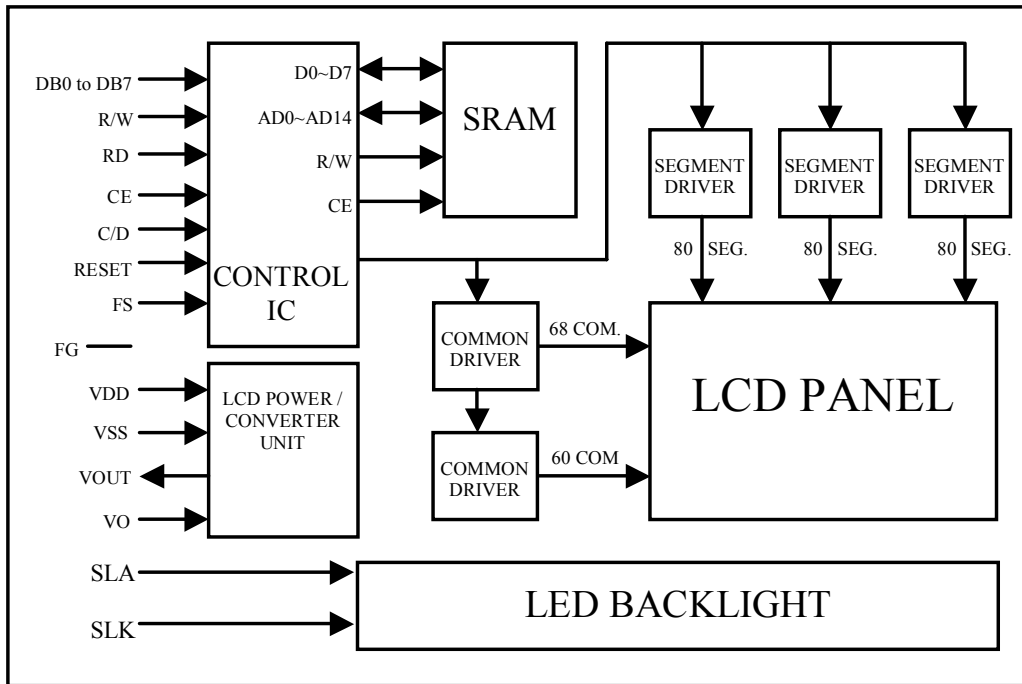

Block Diagram

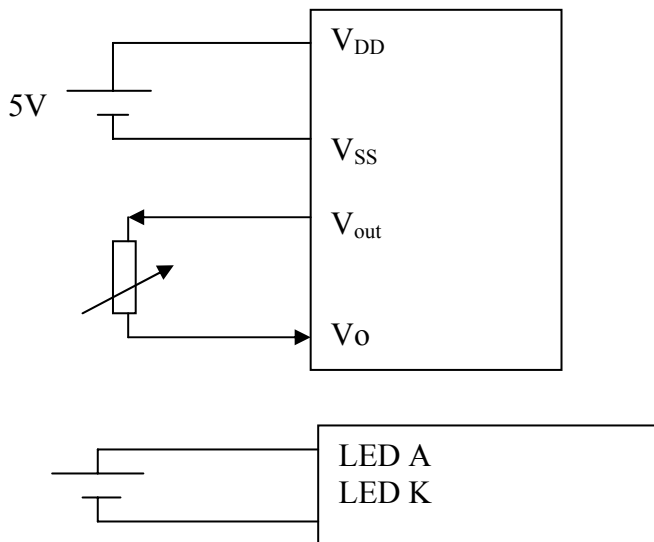

Power Supply



12.0 Quality Assurance

12.1 ZONE DEFINITION

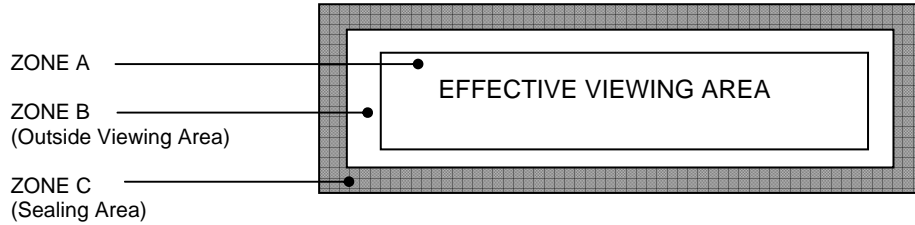

12.2 REJECTION CRITERIA

12.2.1 DIMENSIONAL DEFECTS

Defect Category	Defect Description	Criterion	Drawing Specification
Glass Size	Dimensions of LCD, do not conform to the drawing	Reject	Refer to LCD Physical Dimension Drawing
Perimeter Seal Extension	Perimeter seal epoxy enters the effective viewing area	Reject	
End Seal Size	Size of end seal does not meet drawing specification	Reject	Refer to LCD Physical Dimension Drawing

12.2.2 VISUAL DEFECTS

Defect Category	Defect Description	Criterion	Drawing Specification
Fracture	A type of glass breakage containing running cracks. Inspectors should attempt to remove it with fingernail. If removed, evaluate as chip	Reject – if the size is $\geq 30\%$ of the contact ledge width.	<p>The diagram shows a 3D perspective of a glass panel with a fracture. A double-headed arrow indicates the width of the fracture at the ledge, labeled as $\leq 30\%$ of the ledge width. Another label points to the fracture line, stating 'Fracture does not penetrate through the whole glass thickness'.</p>



Defect Category	Defect Description	Criterion	Drawing Specification
Chip	Chip in cross over area	<p>1) Reject - if the chip causes crossover dot to be exposed</p> <p>2) Chip on outside edge of the glass plate but is greater than 50% of glass thickness at crossover dot is reject able.</p>	
Chip	Chip in contact pad area	Accept if:- a) $X \leq 2.0\text{mm}$ b) $Y \leq 0.5\text{mm}$ c) Z disregard	
	Chip in non-contact pad area	Accept if:- a) $X \leq 6.0\text{mm}$ b) $Y \leq 1.0\text{mm}$ c) Z disregard	
	Chip in perimeter seal area	Accept if:- a) $Y \leq 1/3$ of perimeter seal width (W) b) $X \leq 3.0\text{mm}$ c) Z disregard d) X and Y not touch crossover dot	
Corner Chip	Corner chip within seal area	Accept if:- a) $X \leq 1/3$ of perimeter seal width (W) b) $Y \leq 1/3$ of perimeter seal width (W) c) Z disregard	



Defect Category	Defect Description	Criterion	Drawing Specification
	Corner chip not effecting contact pad / ITO	Accept if:- a) $XY \leq 4\text{mm}^2$ AND b) $Y \leq D$ and $X \leq 2.0\text{mm}$ c) Z disregard	
	Corner chip effecting contact pad / ITO	A) Accept if:- a) $XY \leq 4\text{mm}^2$ AND b) $Y \leq D$ and $X \leq 2.0\text{mm}$ B) Accept if:- a) $X1 \leq 2.0\text{mm}$ b) $Y1 \leq 0.5\text{mm}$ Z disregard	
Glass flare	A thin layer of glass flare at contact area	Accept if:- a) Flare thickness $\leq \frac{1}{4}W$ when $W \leq 3\text{mm}$ b) Flare thickness $\leq 1\text{mm}$ when $W > 3\text{mm}$ W: Contact ledge width	
Glass burr	A rough edge(s) left along the scribing edge (i.e. along the edges of display)	Reject – if the burr cause undersize or oversize of the LCD	Refer to LCD Physical Dimension Drawing
Rainbow	Colored ring in sharp blotches observed	Reject – if 3 or more colored rings in sharp blotches of color are observed. (Limit samples should be used when applicable)	



Defect Category	Defect Description	Criterion	Drawing Specification
Discoloration		Reject - if the discolorations enter the active viewing area of LCD. Color of the LCD shall follow product specification as specified in the manufacturing specification	
Air Void	LC does not fulfill the display	Reject	
Fill end contamination	Discoloration at end seal area	Reject if discoloration exceeded the baffle (for display with baffle) or viewing area (for display without baffle)	

12.2.3 POLARIZER DEFECTS

Defect Category	Defect Description	Criterion	Drawing Specification
Polarizer defect	Polarizer coverage	1- Polarizer should cover effective viewing area of display. 2- It is acceptable if perimeter seal bolder at all sides could be seen. 3- It is acceptable if polarizer attaching position meeting the tolerance mentioned in the drawing. 4- It is reject able if polarizer edge jagged and not even	Refer to LCD Physical Dimension Drawing
	Polarizer Peeling / delamination	1- Reject if any edge or corner of the polarizer is lifted up or not adheres to the glass	
	Polarizer Scratches	1- Any scratch should be acceptable if it is not visible from viewing distance at head of position 2- Polarizer scratch in viewing area is reject able if it is visible from the specified viewing distance 3- Defect, which is visible under surface glare, should be disregard	



Defect Category	Defect Description	Criterion	Drawing Specification																				
	Polarizer damage	1-Stain mark or depression in front polarizer surface should be acceptable if it is not visible from viewing distance at head on position. 2-Defect, which is visible under surface glare, should be disregard																					
	Polarizer bubble / Foreign material	<table border="1"> <thead> <tr> <th rowspan="2">Zone / Dimension</th> <th colspan="3">Acceptable No.</th> </tr> <tr> <th>A</th> <th>B</th> <th>C</th> </tr> </thead> <tbody> <tr> <td>$D \leq 0.30\text{mm}$</td> <td>NC</td> <td>NC</td> <td rowspan="4">NC if the Polarizer not lifted up/ peel off</td> </tr> <tr> <td>$D \leq 0.50\text{mm}$</td> <td>2</td> <td>NC</td> </tr> <tr> <td>$0.50 < D \leq 0.60\text{mm}$</td> <td>1</td> <td>2</td> </tr> <tr> <td>$D > 0.60\text{mm}$</td> <td>0</td> <td>0</td> </tr> </tbody> </table> <p>NC: No count D: Mean Diameter of Defect</p> <p>3 are the totally permissible numbers of bubble</p>	Zone / Dimension	Acceptable No.			A	B	C	$D \leq 0.30\text{mm}$	NC	NC	NC if the Polarizer not lifted up/ peel off	$D \leq 0.50\text{mm}$	2	NC	$0.50 < D \leq 0.60\text{mm}$	1	2	$D > 0.60\text{mm}$	0	0	<p>$D = (A + B)/2$</p>
Zone / Dimension	Acceptable No.																						
	A	B	C																				
$D \leq 0.30\text{mm}$	NC	NC	NC if the Polarizer not lifted up/ peel off																				
$D \leq 0.50\text{mm}$	2	NC																					
$0.50 < D \leq 0.60\text{mm}$	1	2																					
$D > 0.60\text{mm}$	0	0																					

12.2.4 ELECTRICAL TEST DEFECTS

Defect Category	Defect Description	Criterion	Drawing Specification
Missing common	Part of the pattern does not light up	Reject	
Missing segment	One or few segment does not light up	Reject	
Common-common short	Common and common connected	Reject	
Segment-segment short	Segment and segment connected	Reject	
Common – segment short	Common and segment connected	Reject	
Wrong viewing angle	Wrong viewing angle	Reject if display viewing angle not conform to customer requirement	
Metal residue	Extra spot lights up at the border of the segment.	Accept if $\leq 0.20\text{mm}$ (mean diameter)	
Slow response	Response of the display on one side slower than the other side	Reject if it is visible at 30cm distance	



Defect Category	Defect Description	Criterion		Drawing Specification
Pin Hole	Pin hole / void at light up segment	Zone / Dimension	Acceptable No.	
		Located inside single pixel/dot:- $(X + Y)/2 \leq 0.20\text{mm}$	- 1 per pixel/dot - 3 per display (Active Area)	
		Laid over the plural pixel/dots: $(X + Y)/2 \leq 0.20\text{mm}$	- 1 per pixel/dot - 3 per display (Active Area)	
		<i>(3/4 or larger part of dot area has to be effective for display)</i>		
Deformed display dot	Lacked deformation	Accept if: i) $X \leq 0.15$ and ii) $Y \leq 0.15$		
	Added deformation	Accept if: i) $X < 0.02$ and ii) $Y < 0.02$		
Reverse twist/tilt	Segment are darker or clearer than other area of the same segment	Reject		
Misalignment	Segment fatter or smaller or extra segment	Reject if $> 10\%$ of designed segment width and visible at 30cm distance		
Segment Smearing	Light up segment smear	Reject		
Dim segment	Display shows poor contrast at pre set voltage	Reject		

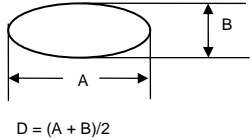

12.2.5 BLACK SPOT, WHITE SPOT AND FOREIGN MATERIAL (SOLID FIGURE)

Defect Category	Defect Description	Criterion			Drawing Specification	
Black Spot, White Spot and Foreign Material	Black Spot, White Spot and Foreign Material	Zone / Dimension	Acceptable No.			
			A	B	C	
		$D \leq 0.10\text{mm}$	NC	NC	NC	
		$0.10 < D \leq 0.15\text{mm}$	3	3	NC	
		$0.15 < D \leq 0.25\text{mm}$	1	2	NC	
		$0.25 < D \leq 0.35\text{mm}$	1	1	NC	
		$D > 0.35 \text{ mm}$	0	0	NC	
		NC: No count D: Mean Diameter of Defect				

NOTE: The 1/3 or larger parts of individual dot has to be lighted on.
The solid figure is that the defect has clear-cut outline at the optimum driving condition in both positive and negative, of which size does not change when the contrast changes.

12.2.6 BLACK SPOT, WHITE SPOT AND FOREIGN MATERIAL (FADED FIGURE)

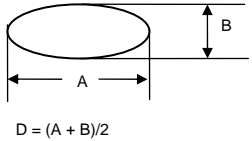
Defect Category	Defect Description	Criterion			Drawing Specification	
Black Spot, White Spot and Foreign Material	Black Spot, White Spot and Foreign Material	Zone / Dimension	Acceptable No.			
			A	B	C	
		$D \leq 0.60\text{mm}$	NC	NC	NC	
		$0.60 < D \leq 0.70\text{mm}$	3		NC	
		$0.70 < D \leq 0.80\text{mm}$	1		NC	
		$D > 0.80 \text{ mm}$	0		NC	
NC: No count D: Mean Diameter of Defect						

NOTE: Faded figure means that the defects has unclear outline at the optimum driving condition in both positive and negative, of which size seems to change when the contrast changes.



12.2.7 LINE SHAPE AND SCRATCHES

Defect Category	Defect Description	Criterion					Drawing Specification
Line shape and scratches	Line shape and scratches	Zone /Dimension		Acceptable No.			
		X	Y	A	B	C	
		NC	≤ 0.03mm	NC	NC	NC	
		≤ 2 mm	≤ 0.05mm	1	1	NC	
		≤ 1 mm	≤ 0.10mm	1	2	NC	
		NC	≥ 0.10mm	Due to (1) round defect			

NOTE: Length is X and Width is Y.

REMARK:

i) Total amount of spot defects including round and linear – A total of 5 permissible numbers of defects in Zone A & B including above (14.2.5), (14.2.6), (14.2.7). Regardless of number of defects, the minimum distance between individual defects have to be 5mm or larger.

ii) All the other items of inspection that are not included herein must be determined by the “Limit Standard” sample, which were occasionally set up with the mutual consent of both parties. In every case of the items set up with the Limit Standard, the Limit Standard always takes precedence over the other means of definition.



13. Precaution for using LCM

1. Liquid Crystal Display (LCD)

LCD is made up of glass, organic sealant, organic fluid and polymer based polarizers. The following precautions should be taken when handling.

- b) Keep the temperature within the range of use and storage. Excessive temperature and humidity could cause polarization degradation, polarizer peel off or bubble.
- c) Do not contact the exposed polarizer with anything harder than HB pencil lead. To clean dust off the display surface, wipe gently with cotton, chamois or other soft material soaked in petroleum benzine.
- d) Wipe off saliva or water drops immediately. Contact with water over a long period of time may cause polarizer deformation or colour fading, while an active LCD with water condensation on its surface will cause corrosion of ITO electrodes.
- e) Glass can be easily chipped or cracked from rough handling, especially at corners and edges.
- f) Do not drive LCD with DC voltage.

2. Liquid Crystal Display Modules.

2.1 Mechanical Considerations

LCM are assembled and adjusted with a high degree of precision. Avoid excessive shocks and do not make any alterations or modification. The following should be noted.

- a) Do not tamper in any way with the tabs on the metal frame.
- b) Do not modify the PCB by drilling extra holes, changing its outline, moving its component or modifying its pattern.
- c) Do not touch the elastomer connector, especially insert a backlight panel (for example, EL)
- d) When mounting a LCM make sure that the PCB is not under any stress such as bending or twisting. Elastomer contacts are very delicate and missing pixels could result from slight dislocation of any of the elements.

- a) Avoid pressing on the metal bezel, otherwise the elastomer connector could be deformed and lose contact, resulting in missing pixels.

2.2 Static Electricity

LCM contains CMOS LSI's and the same precaution for such devices should apply, namely

- a) The operator should be grounded whenever he/she comes into contact with the module. Never touch any of the conductive parts such as the LSI pads, the copper leads on the PCB and the interface terminals with any parts of the human body.
- b) The modules should be kept in antistatic bags or other containers to static for storage.
- c) Only properly grounded soldering irons should be used.
- d) If an electric screwdriver is used, it should be well grounded and shielded from commutator spark.
- e) The normal static prevention measures should be observed for work clothes and working benches, the latter conductive (rubber) mat is recommended.
- f) Since dry air is inductive to statics, a relative humidity of 50-60% is recommended.

2.3 Soldering

- a) Solder only to the I/O terminals.
- b) Use only soldering irons with proper grounding and no leakage.
- c) Soldering temperature: 280 °C
- d) Soldering time: 3 to 4 sec
- e) Use eutectic solder with resin flux fill.
- f) If flux is used, the LCD surface should be covered to avoid flux spatters. Flux residue should be removed afterwards.



2.4 Operation

- a) The contrast can be adjusted by varying the LCD driving voltage V_0
- b) Driving voltage should be kept within specified range, excess voltage shortens display life.
- c) Response time increases with decrease in temperature.
- d) Display may turn black or dark blue at temperature above its operational range, this is (however not pressing on the viewing area) may cause the segments to appear “fractured”.
- e) Mechanical disturbance during operation (such as pressing on the viewing area) may cause the segments to appear “fractured”.

2.5 Storage

If any fluid leaks out of the damaged glass cell, wash off any human part that comes into contact with soap and water. Never swallow the fluid. The toxicity is extremely low but caution should be exercised at all the time.

2.6 Limited Warranty

Unless otherwise agreed between Crystal Clear Technology and customer, Crystal Clear Technology will replace or repair any of its LCD and LCM which is found to be defective electrically and visually when inspected in accordance with Crystal Clear Technology acceptance standards, for a period of one year from date of shipment. Confirmation of such date shall be based on freight documents. The warranty liability of Crystal Clear Technology is limited to repair and/or replacement on the terms set forth above. Crystal Clear Technology will not be responsible for any subsequent or consequential events.

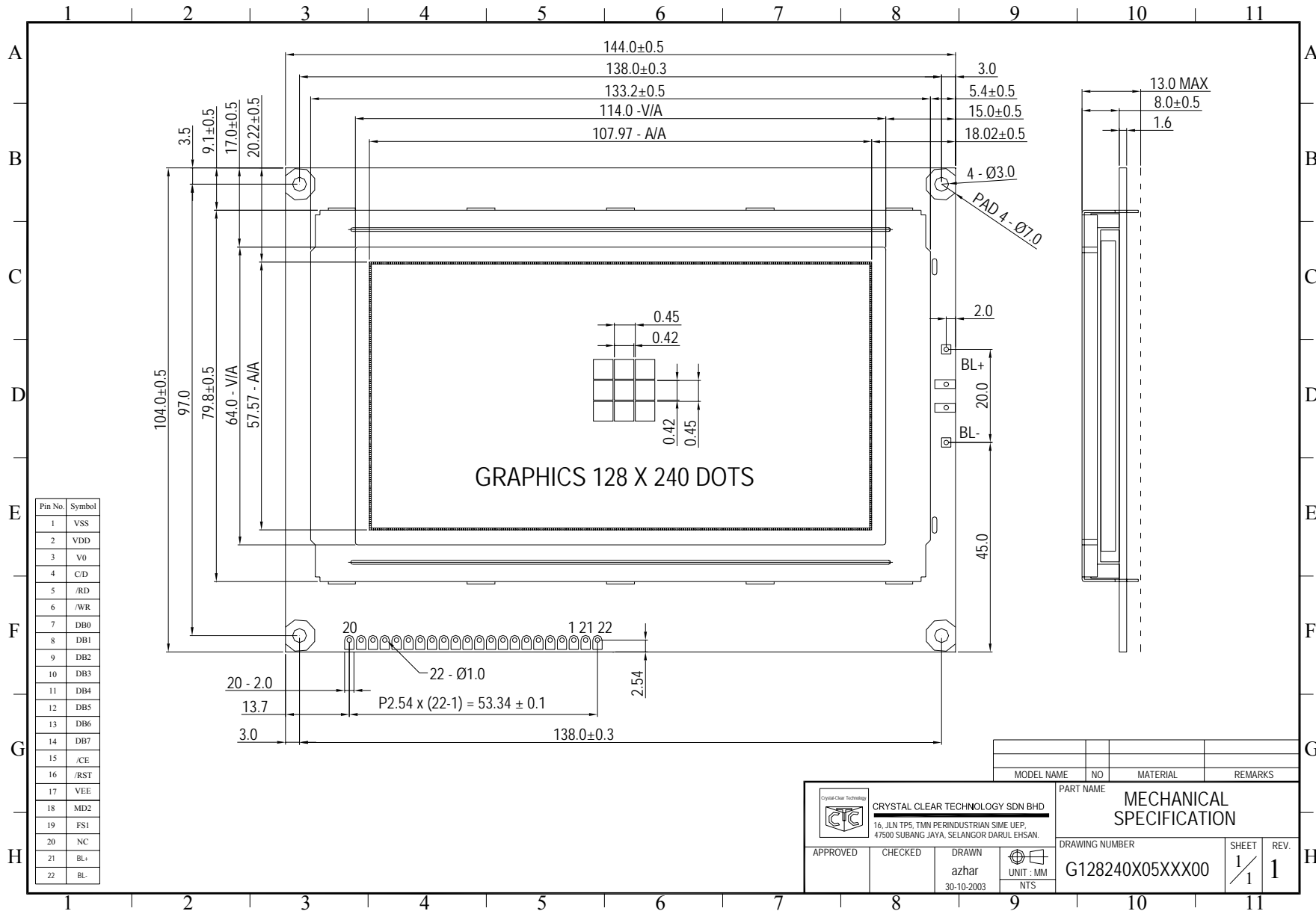

MODEL NAME	NO	MATERIAL	REMARKS

		CRYSTAL CLEAR TECHNOLOGY SDN BHD 16, JLN TPS, TMN PERINDUSTRIAN SIME UEP, 47500 SUBANG JAYA, SELANGOR DARUL EHSAN.		PART NAME MECHANICAL SPECIFICATION	
APPROVED 	CHECKED 	DRAWN azhar 30-10-2003	 UNIT : MM NTS	DRAWING NUMBER G128240X05XXX00	SHEET 1/1 REV. 1



Crystal Clear Technology
16 Jalan TP5—Taman Perindustrian Sime UEP
47600 Subang Jaya—Selangor DE
Malaysia