

Crystal Clear Technology

Product Specification

G128240x06 series

Crystal Clear Technology sdn. bhd.

16Jalan TP5—Taman Perindustrian Sime UEP
47600 Subang Jaya—Selangor DE
Malaysia. T: +603 80247099 F: +603 80247098



1.0 Table of Contents

	Page
1. Table of Contents	1
2. Record of revision	2
3. General specification	3
4. Absolute maximum ratings	4
5. Electrical characteristics	4
6. Environmental requirement	4
7. LCD specification	5 ~ 7
8. Interface	8
9. Functional Description	9 ~ 14
10. Instructions	15
11. Power supply	16
12. Quality assurance	17 ~ 24
13. Precautions in use LCM	25 ~ 26
14. Outline drawing	27
15. LCD Segment and Common Layout	28



2.0 Record of revision

Rev	Date	Item	Page	Comment	Originator	Checked By
1.0	16/12/08			Initial Release	Syam	Azhar



3.0 General specification

Display format: Graphics 240 (w) x 128 (h) dots

Dot size: 0.36 (w) x 0.36 (h) mm

Dot pitch: 0.38 (w) x 0.38 (h) mm

View area: 95.0 (w) x 52.0 (h) mm

Active area: 91.18 (w) x 48.62 (h) mm

General dimensions: 119.5 (w) x 67.0 (h) x 6.2 (t) mm

Controller/Driver: UC1608 or equivalent

Interface: Parallel/Serial

Driving method: 1/128 duty, 1/12 bias

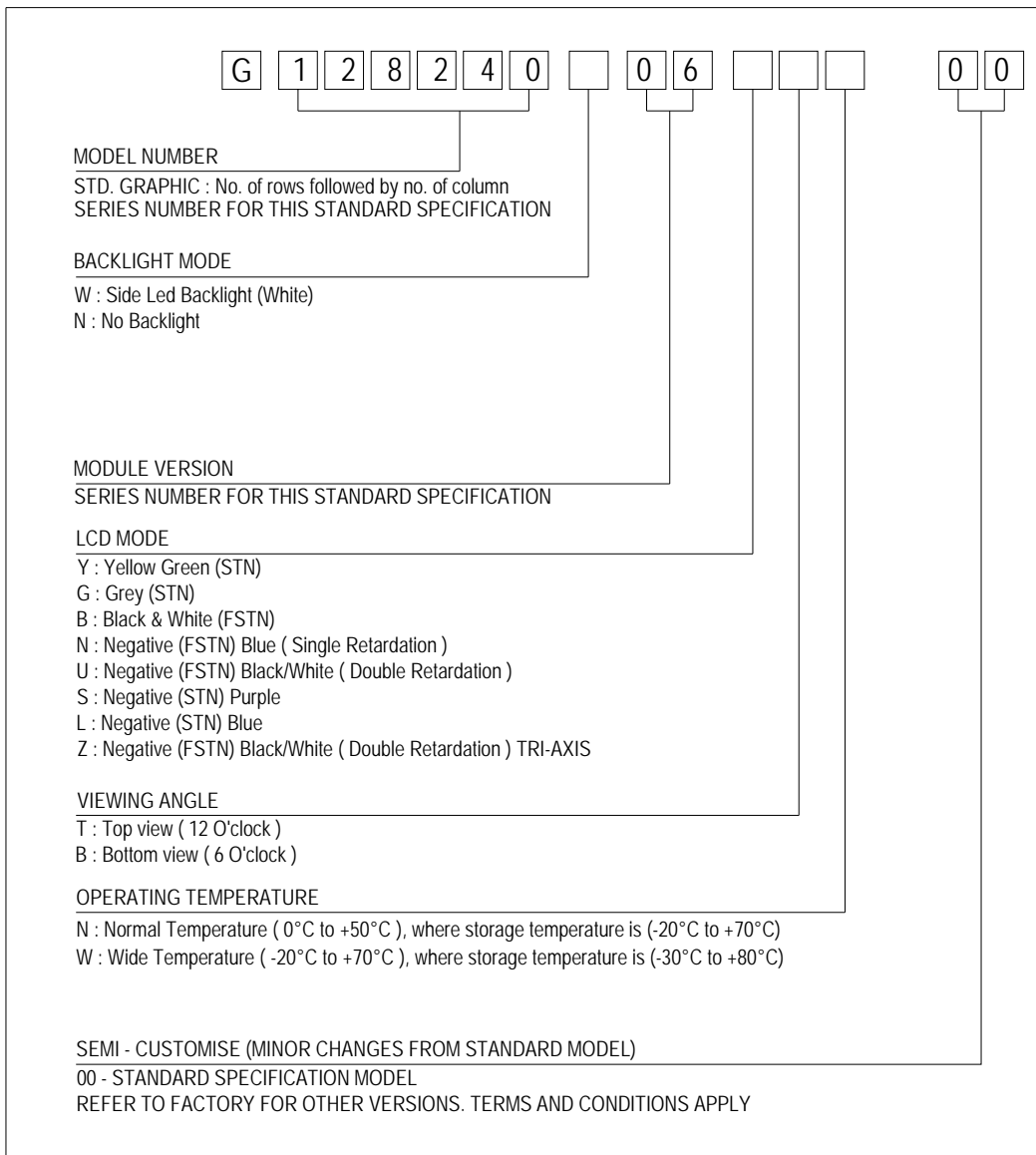

**4.0 Absolute maximum rating (at V_{SS} = 0V, ambient temperature = 25°C)**

NO	ITEM	SIMBOL	MIN	MAX	UNIT
1.	Logic Supply Voltage	V _{DD}	-0.3	+4.0	V
2.	LCD Generated Voltage	V _{LCD}	-0.3	+17.0	V
3.	Operating Temperature	T _{op}	Refer page 3		°C
4.	Storage Temperature	T _{st}	Refer page 3		°C

5.0 Electrical characteristics

NO	ITEM	SYMBOL	CONDITION	MIN	TYP	MAX	UNIT
1.	Operating Voltage	V _{DD}	-	2.7	3.0	3.3	V
2.	Power Supply voltage to LCD	V _{LCD}	25°C	13.0±5%			V
3.	Current Supply	I _{DD}	V _{DD} = 3.0V	-	0.70	1.5	mA

5.1 Backlight Options

NO	COLOR	FORWARD VOLTAGE (V)			FORWARD CURRENT (mA)			MIN BRIGHTNESS (cd/m ²) *
		Min	Typ.	Max	Min	Typ.	Max	
1.	White	-	4.0	-	-	90	120	300

- *Note :
- Brightness measured at backlight surface.
 - On LCD surface, brightness is only about 10% to 15% of backlight brightness.
 - Lifetime of backlight: For YG, Amber, Red = 50K hrs. For White, Blue = 20K hrs

6.0 Environmental requirements

NO	ITEM	CONDITION
1.	Operating Temperature	Refer page 3
2.	Storage Temperature	Refer page 3
3.	Operating Humidity	5% to 95%RH
4.	Cycle Test	0 C @ 30 min to 50 C @ 30min for 1 cycle run for 10 cycles
5.	Lifetime	50000 HOURS (excluding backlight)

Note: The background on LCD has the possibility to be changed in different temperature range.



7.0 LCD specification

7.1 Electro-optical characteristics (at ambient temperature = 25°C)

NO	ITEM	SYMBOL	CONDITION	LCD TYPE							REF.
				STN YG	STN GREY	STN -VE BLUE/PURPLE	FSTN +VE B/W	FSTN -VE BLUE	FSTN -VE TRUE B/W	FSTN -VE TRI AXIS	
1	Operating Voltage (Volt)	V_{LCD}	$\theta = 0$ $Cr = \max$	13.0 ± 5%							7.1.1
2	Viewing Angle (Deg)	$\theta x 1$	$CR \geq 2$ $V_{LCD} = 14.7V$	+20	+15	+35	+20	+35	+30	+40	7.1.2
		$\theta x 2$		-20	-15	-35	-20	-35	-35	-40	
		$\theta y 1$		-25	-20	-30	-25	-30	-30	-50	
		$\theta y 2$		+25	+20	+30	+25	+30	+30	+30	
3	Contrast Ratio	CR	$\theta = 0^0$ $V_{LCD} = 14.7V$	2.5	2.0	5.5	2.5	5.5	15	15	7.1.3
4	Response Time (msec)	Rise Time (Tr)	$\theta = 0^0$	400							7.1.4
		Decay Time (Td)	$\theta = 0^0$	400							

Note:

1. Viewing angle data is based on bottom view product by default. Should it be a top view product, values are then swap.
2. Contrast ratio is based on typical data when using white colour as backlight.
3. Equipment Used Eldim; Ez Contrast 120R , Spot Size = 2mm

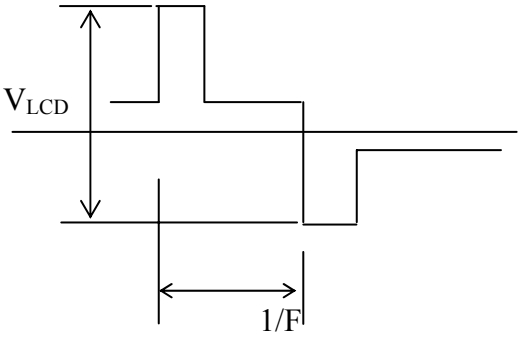
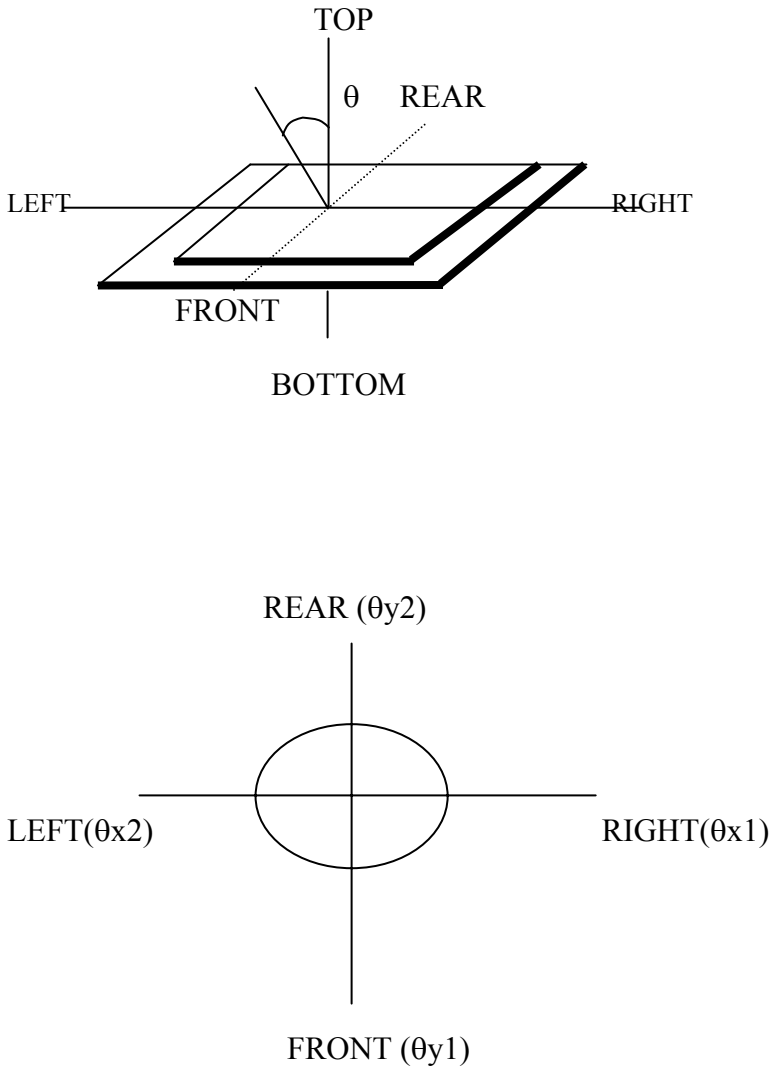

NO	CHARACTERISTICS	DEFINITIONS
7.1.1	Definition of Operating Voltage (V_{LCD})	 <p>V_{LCD} : Operating Voltage F : Frame Frequency</p>
7.1.2	Definition of Viewing Angle	

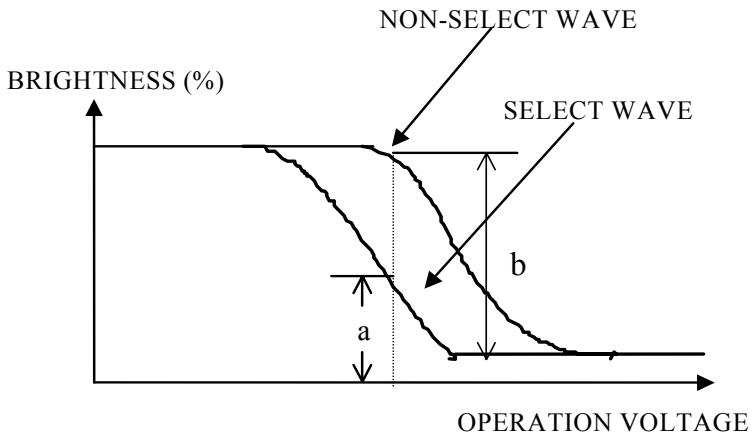
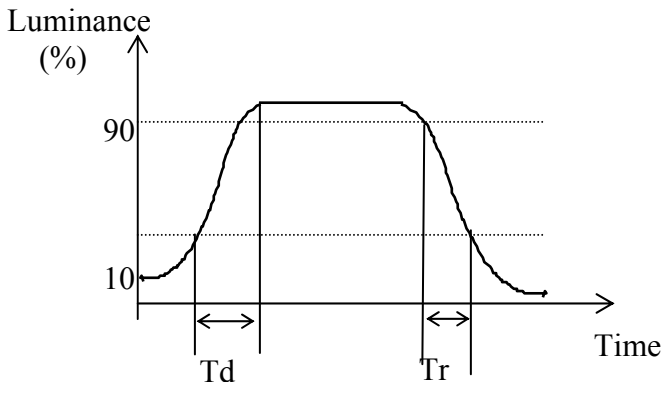
<p>7.1.3</p>	<p>Definition of Contrast Ratio</p>	 <p>Contrast Ratio = $\frac{\text{Brightness of non-selected state (b)}}{\text{Brightness of selected state (a)}}$</p> <p>Conditions</p> <ul style="list-style-type: none"> (a) Operating Voltage: V_{LCD} (b) Temperature: $25^{\circ}C$ (c) Viewing Angle, $\theta = 0^{\circ}$
<p>7.1.4</p>	<p>Response Time</p>	 <p>Tr: Measured between 10% and 90% of LCD segment maximum response with V_{ON}.</p> <p>Td: With voltage switches to zero and the instant LCD segment reaches 10% of its maximum response.</p>

**8.0 Interface**

8.1	Display Driver	UC1608 OR EQUIVALENT	
8.2	Pin No	Symbol	Description
	1	BM1	Bus mode interface
	2	BM2	Bus mode interface
	3	CS	Chip select
	4	RST	Reset command
	5	CD	Select control or display data
	6	WR0	Read/Write control pin
	7	WR1	Read/Write control pin
	8	D0 (SCK)	Bi-directional data bus (serial clock)
	9	D1	Bi-directional data bus
	10	D2	Bi-directional data bus
	11	D3 (SDA)	Bi-directional data bus (serial data)
	12	D4	Bi-directional data bus
	13	D5	Bi-directional data bus
	14	D6	Bi-directional data bus
	15	D7	Bi-directional data bus
	16	VDD	Logic supply voltage
	17	VSS	Ground
	18	VBIAS	Reference voltage to generate actual SEG driving voltage
	19	VLCD	Main LCD power supply
	20	VB0+	LCD bias voltage
	21	VB0-	LCD bias voltage
	22	VB1+	LCD bias voltage
	23	VB1-	LCD bias voltage



9.0 Functional Descriptions
 9.1 Read/Write timing characteristics

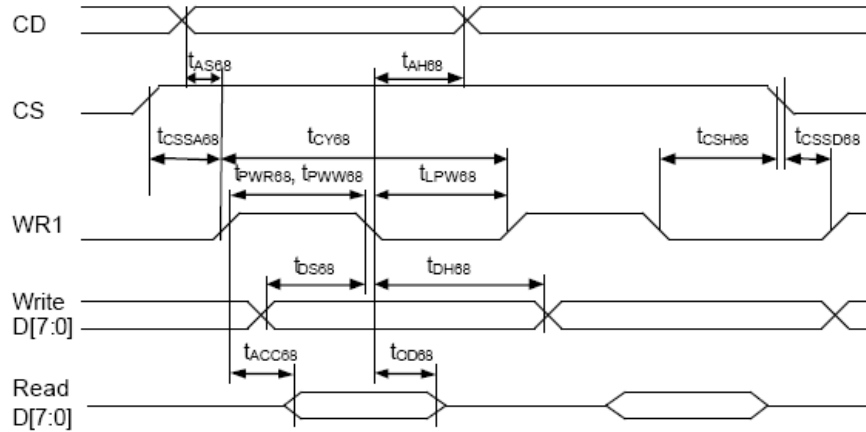

FIGURE 16: Parallel Bus Timing Characteristics (for 6800 MCU)

($2.7V \leq V_{DD} < 3.3V$, $T_a = -30$ to $+85^\circ C$)

Symbol	Signal	Description	Condition	Min.	Max.	Units
t _{AS68}	CD	Address setup time		0	-	nS
t _{AH68}	CD	Address hold time		20	-	nS
T _{CY68}		System cycle time			-	nS
		8 bits bus (read)		140		
		(write)		140		
		4 bits bus (read)		140		
		(write)		140		
t _{PWR68}	WR1	Pulse width 8 bits (read)		65	-	nS
		4 bits		65	-	nS
t _{PWW68}		Pulse width 8 bits (write)		35	-	nS
		4 bits		35	-	nS
t _{LPW68}		Low pulse width			-	nS
		8 bits bus (read)		65		
		(write)		35		
		4 bits bus (read)		65		
		(write)		35		
t _{DS68}	D0~D7	Data setup time		30	-	nS
t _{DH68}	D0~D7	Data hold time		20	-	nS
t _{ACC68}		Read access time	C _L = 100pF	-	60	nS
t _{OD68}		Output disable time		12	20	nS
t _{CSSA68}	CS1/CS0	Chip select setup time		10		nS
t _{CSSD68}	CS1/CS0	Chip select setup time		10		nS
t _{CSH68}	CS1/CS0	Chip select setup time		20		nS

Read/Write characteristics (6800 series MPU)

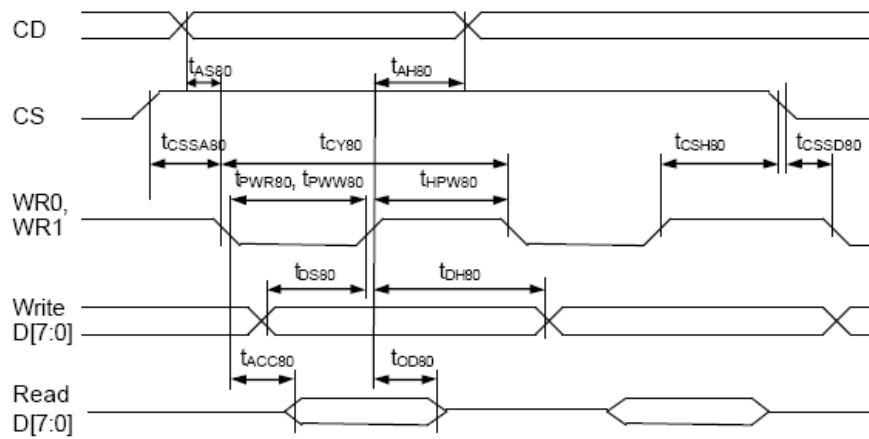

FIGURE 15: Parallel Bus Timing Characteristics (for 8080 MCU)

($2.7V \leq V_{DD} < 3.3V$, $T_a = -30$ to $+85^\circ C$)

Symbol	Signal	Description	Condition	Min.	Max.	Units
t_{AS80}	CD	Address setup time		0	-	nS
t_{AH80}		Address hold time		20	-	nS
t_{CY80}		System cycle time				nS
		8 bits bus (read)		140	-	nS
		(write)		140	-	nS
		4 bits bus (read)		140	-	nS
		(write)		140	-	nS
t_{PWR80}	WR1	Pulse width 8 bits (read)		65	-	nS
		4 bits		65	-	nS
t_{PWW80}	WR0	Pulse width 8 bits (write)		35	-	nS
		4 bits		35	-	nS
t_{HPW80}	WR0, WR1	High pulse width				nS
		8 bits bus (read)		65	-	nS
		(write)		35	-	nS
		4 bits bus (read)		65	-	nS
		(write)		35	-	nS
t_{DS80}	D0-D7	Data setup time		30	-	nS
t_{DH80}		Data hold time		20	-	nS
t_{ACC80}		Read access time	$C_L = 100pF$	-	60	nS
t_{OD80}		Output disable time		12	20	nS
t_{SSA80}	CS1/CS0	Chip select setup time		10		nS
t_{CSSD80}				10		nS
t_{CSH80}				20		nS

Read/Write characteristics (8080 series MPU)

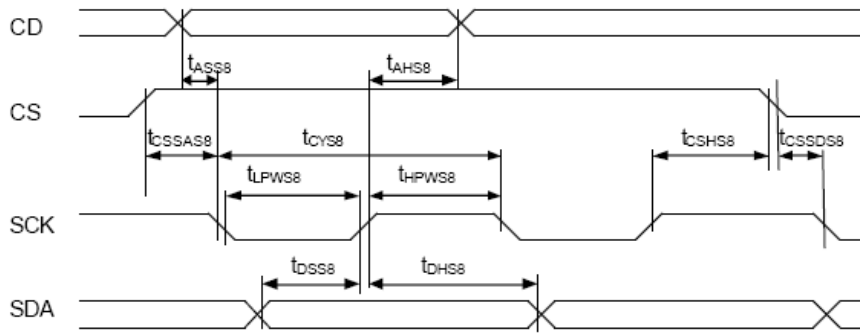

FIGURE 17: Serial Bus Timing Characteristics (for S8)

($2.7V \leq V_{DD} < 3.3V$, $T_a = -30$ to $+85^\circ C$)

Symbol	Signal	Description	Condition	Min.	Max.	Units
t_{ASS8}	CD	Address setup time		0	-	nS
t_{AHS8}		Address hold time		20	-	nS
t_{CYS8}	SCK	System cycle time		140	-	nS
t_{LPWS8}		Low pulse width		65	-	nS
t_{HPWS8}		High pulse width		65	-	nS
t_{DSS8}	SDA	Data setup time		30	-	nS
t_{DHS8}		Data hold time		20	-	nS
t_{CSSAS8}	CS	Chip select setup time		10		nS
t_{CSSDS8}				20		
t_{CSHS8}				10		

Read/Write characteristics (Serial Interface 4 Line)

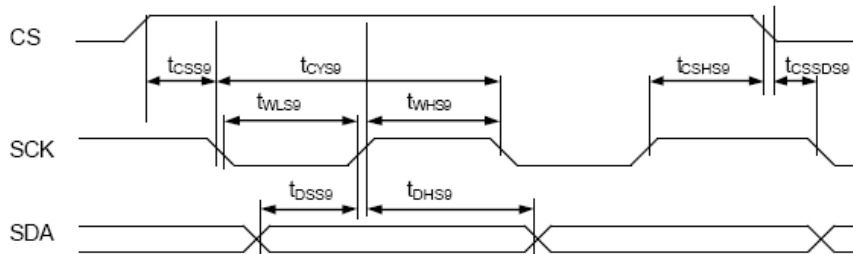

FIGURE 18: Serial Bus Timing Characteristics (for S9)

($2.7V \leq V_{DD} < 3.3V$, $T_a = -30$ to $+85^\circ C$)

Symbol	Signal	Description	Condition	Min.	Max.	Units
t_{CYS9}	SCK	System cycle time		140	-	nS
t_{LPWS9}		Low pulse width		65	-	nS
t_{HPWS9}		High pulse width		65	-	nS
t_{DSS9}	SDA	Data setup time		30	-	nS
t_{DHS9}		Data hold time		20	-	nS
t_{CSSAS9}	CS	Chip select setup time		10		nS
t_{CSSDS9}				20		
t_{CSHS9}				10		

Read/Write characteristics (Serial Interface 3 Line)

9.2 Application Circuits

9.2.1 6800 – Series Parallel Interface

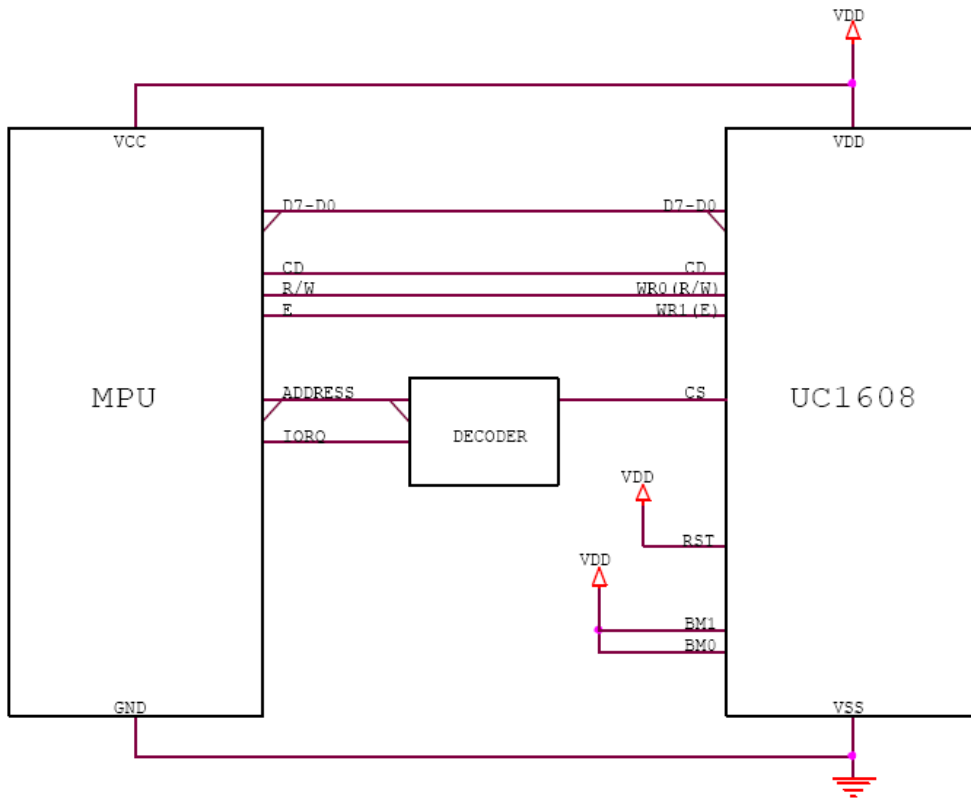

FIGURE 7 : 6800/8bit parallel mode reference circuit

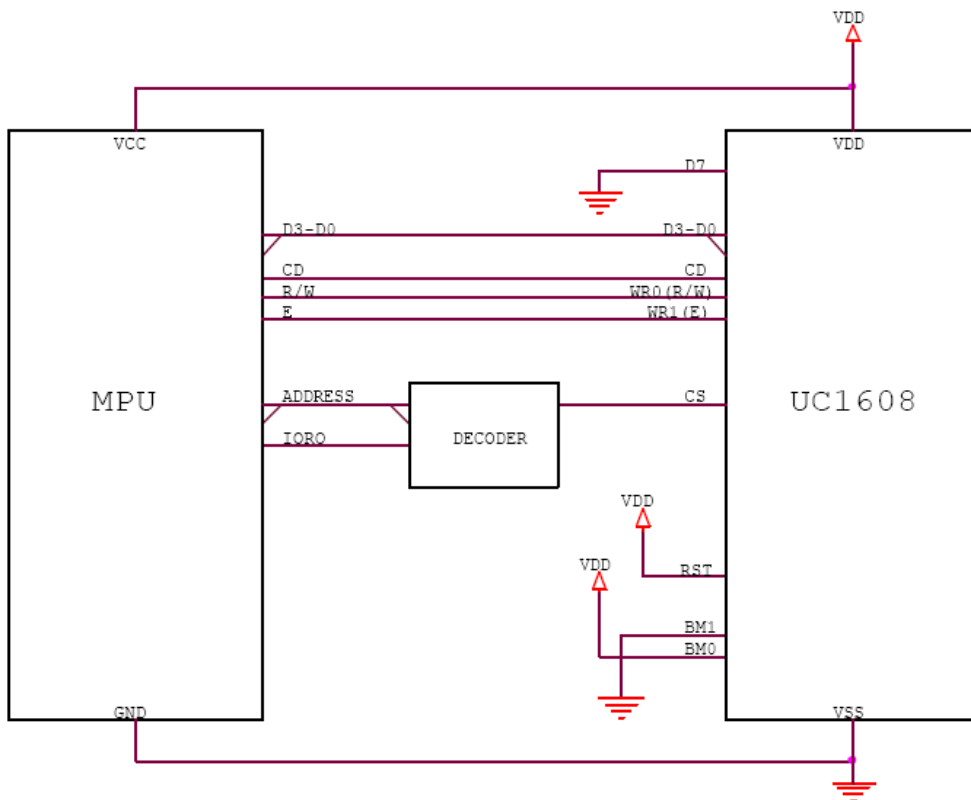

FIGURE 8 : 6800/4bit parallel mode reference circuit

9.2.2 8080 – Series Parallel Interface

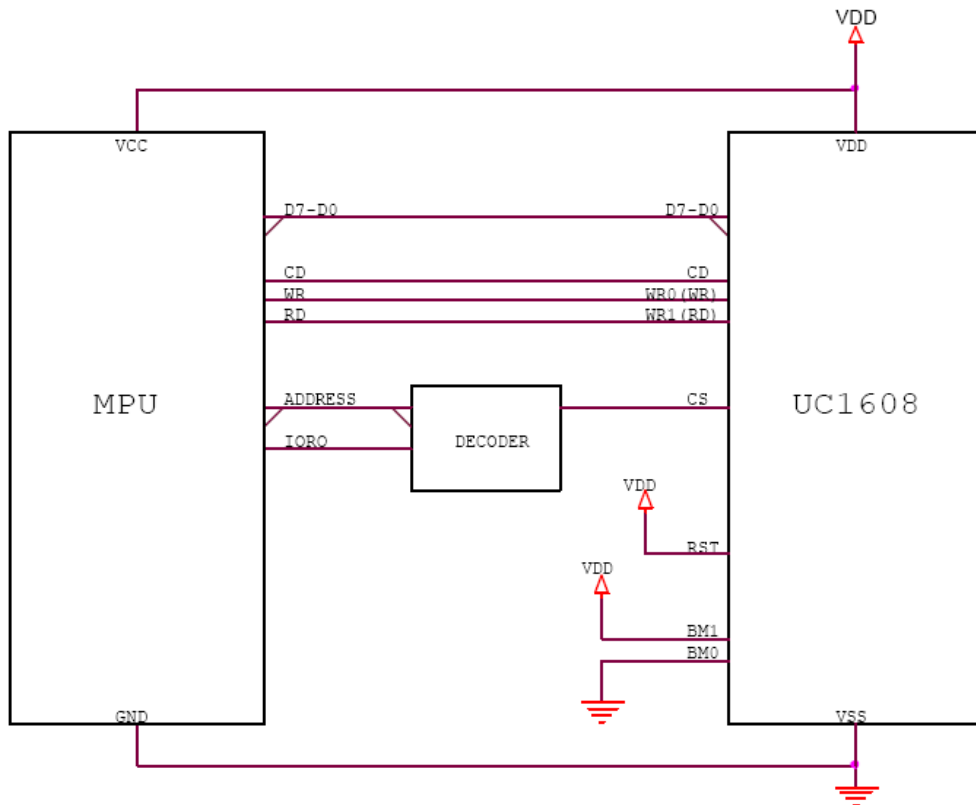

FIGURE 5: 8080/8bit parallel mode reference circuit

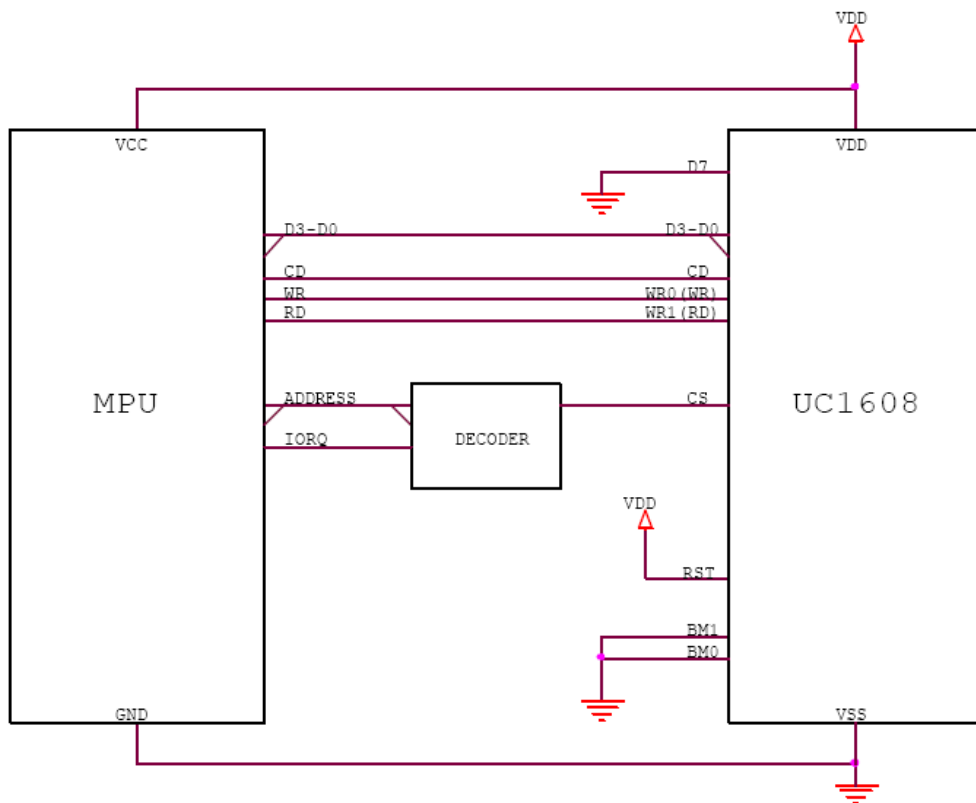

FIGURE 6: 8080/4bit parallel mode reference circuit

9.2.3 3 Lines Serial Interface

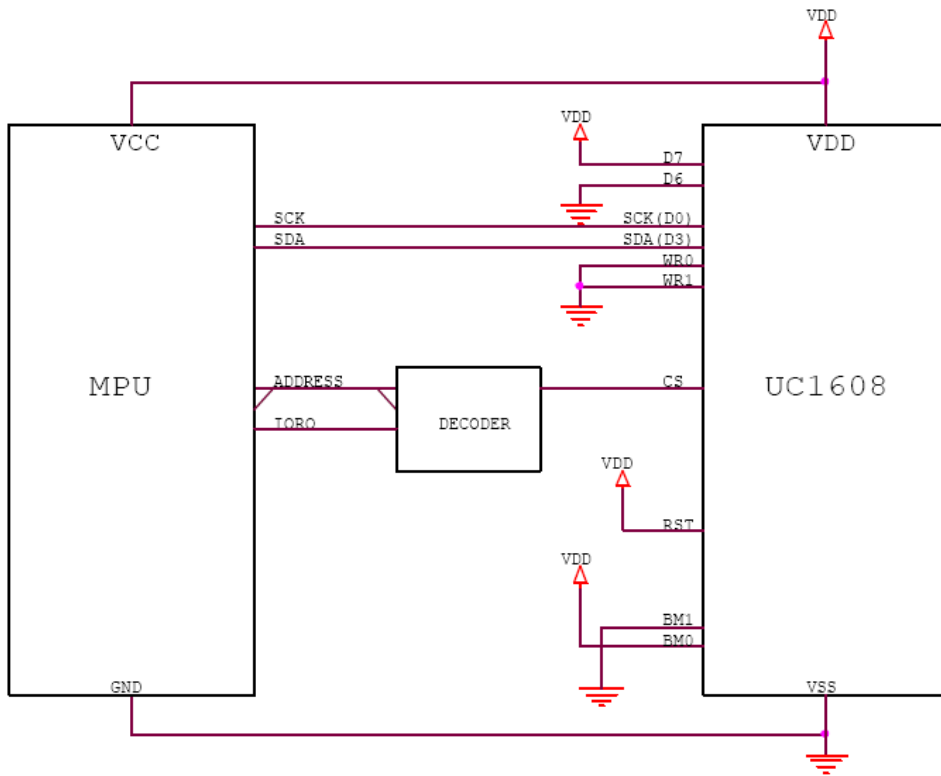

FIGURE 11 : 3-Wires SPI (S9) serial mode reference circuit

9.2.4 4 Lines Serial Interface

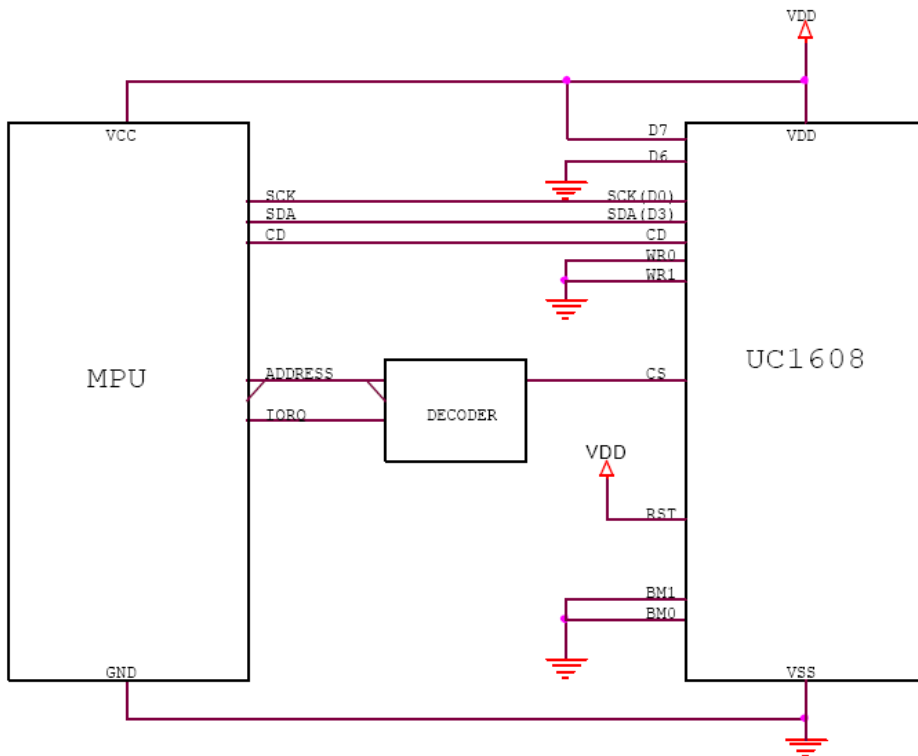

FIGURE 9 : 4-Wires SPI (S8) serial mode reference circuit



10. Instruction set

The following is a list of host commands supported by UC1608

C/D: 0: Control, 1: Data
 W/R: 0: Write Cycle, 1: Read Cycle
 # Useful Data bits
 – Don't Care

	Command	C/D	W/R	D7	D6	D5	D4	D3	D2	D1	D0	Action	Default
1	Write Data Byte	1	0	#	#	#	#	#	#	#	#	Write 1 byte	N/A
2	Read Data Byte	1	1	#	#	#	#	#	#	#	#	Read 1 byte	N/A
3	Get Status	0	1	BZ	MX	DE	RS	WA	GN1	GN0	1	Get Status	N/A
4	Set Column Address LSB	0	0	0	0	0	0	#	#	#	#	Set CA[3:0]	0
	Set Column Address MSB	0	0	0	0	0	1	#	#	#	#	Set CA[7:4]	0
5	Set Mux Rate and temperature compensation.	0	0	0	0	1	0	0	#	#	#	Set {MR, TC[1:0]}	MR: 1b TC: 00b
6	Set Power Control	0	0	0	0	1	0	1	#	#	#	Set PC[2:0]	101b
7	Set Adv. Program Control. (double byte command)	0	0	0	0	1	1	0	0	0	R	For UltraChip only. Do not use.	N/A
		0	0	#	#	#	#	#	#	#	#		
8	Set Start Line	0	0	0	1	#	#	#	#	#	#	Set SL[5:0]	0
9	Set Gain and Potentiometer (double-byte command)	0	0	1	0	0	0	0	0	0	1	Set {GN[1:0], PM[5:0]}	GN=3 PM=0
		0	0	#	#	#	#	#	#	#	#		
10	Set RAM Address Control	0	0	1	0	0	0	1	#	#	#	Set AC[2:0]	001b
11	Set All-Pixel-ON	0	0	1	0	1	0	0	1	0	#	Set DC[1]	0=disable
12	Set Inverse Display	0	0	1	0	1	0	0	1	1	#	Set DC[0]	0=disable
13	Set Display Enable	0	0	1	0	1	0	1	1	1	#	Set DC[2]	0=disable
14	Set Fixed Lines	0	0	1	0	0	1	#	#	#	#	Set FL[3:0]	0
15	Set Page Address	0	0	1	0	1	1	#	#	#	#	Set PA[3:0]	0
16	Set LCD Mapping Control	0	0	1	1	0	0	#	#	#	#	Set LC[3:0]	0
17	System Reset	0	0	1	1	1	0	0	0	1	0	System Reset	N/A
18	NOP	0	0	1	1	1	0	0	0	1	1	No operation	N/A
19	Set LCD Bias Ratio	0	0	1	1	1	0	1	0	#	#	Set BR[1:0]	10b=12
20	Reset Cursor Mode	0	0	1	1	1	0	1	1	1	0	AC[3]=0, CA=CR	N/A
21	Set Cursor Mode	0	0	1	1	1	0	1	1	1	1	AC[3]=1, CR=CA	N/A
22	Set Test Control (double byte command)	0	0	1	1	1	0	0	1	TT		For UltraChip only. Do not use.	N/A
		0	0	#	#	#	#	#	#	#	#		

* Other than commands listed above, all other bit patterns may result in undefined behavior.

11. Power Supply

HI-V GENERATOR CIRCUIT

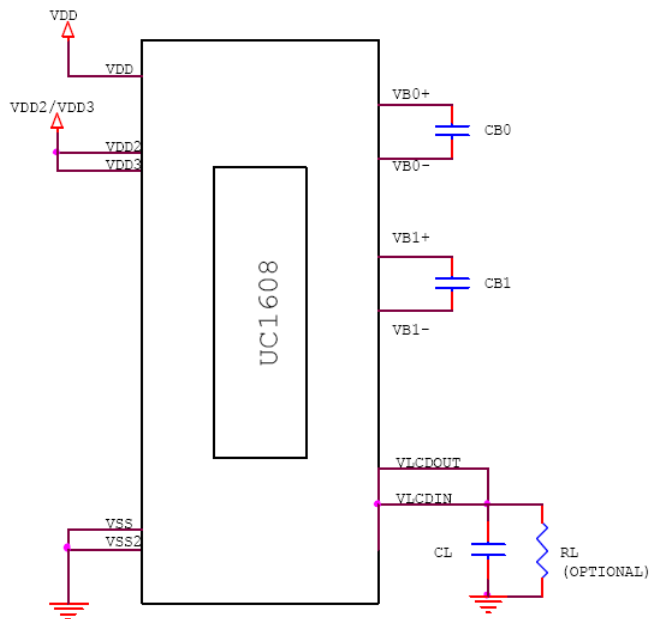

FIGURE 1: Reference circuit using internal Hi-V generator circuit

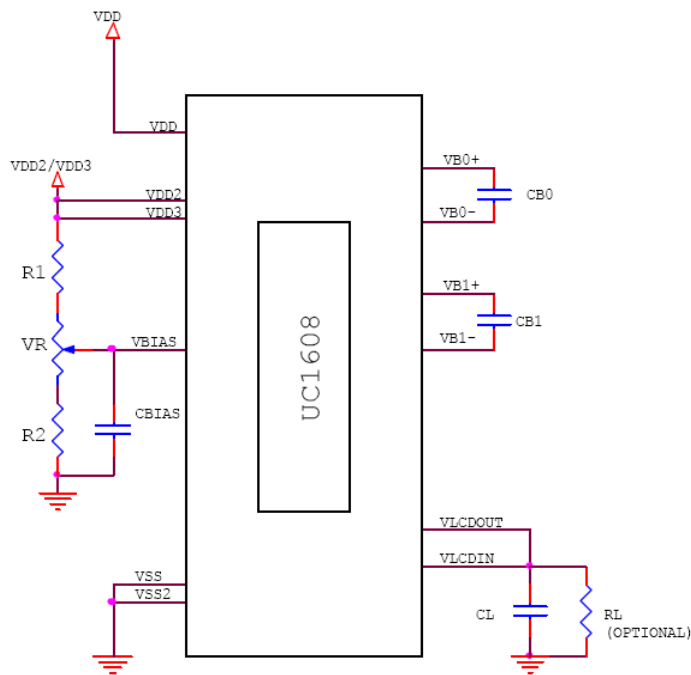
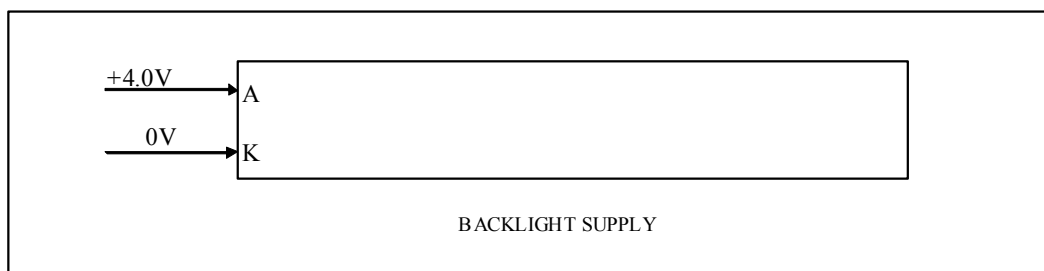

Figure 2: Reference circuit using external Bias source





12.0 Quality Assurance

12.1 ZONE DEFINITION

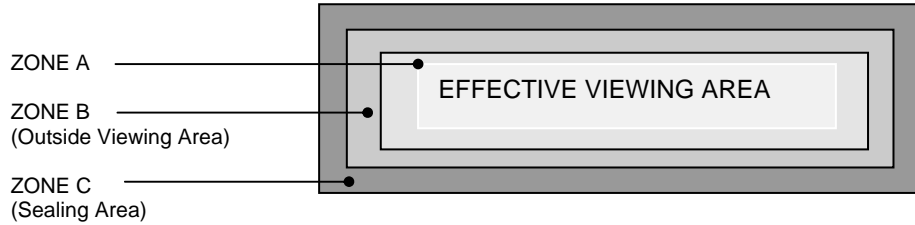

12.2 REJECTION CRITERIA

12.2.1 DIMENSIONAL DEFECTS

Defect Category	Defect Description	Criterion	Drawing Specification
Glass Size	Dimensions of LCD, do not conform to the drawing	Reject	Refer to LCD Physical Dimension Drawing
Perimeter Seal Extension	Perimeter seal epoxy enters the effective viewing area	Reject	
End Seal Size	Size of end seal does not meet drawing specification	Reject	Refer to LCD Physical Dimension Drawing

12.2.2 VISUAL DEFECTS

Defect Category	Defect Description	Criterion	Drawing Specification
Fracture	A type of glass breakage containing running cracks. Inspectors should attempt to remove it with fingernail. If removed, evaluate as chip	Reject – if the size is $\geq 30\%$ of the contact ledge width.	<p>The diagram shows a cross-section of a glass ledge with a fracture. A dimension line indicates the fracture length is $\leq 30\%$ of the ledge width. A note states 'Fracture does not penetrate through the whole glass thickness'.</p>



Defect Category	Defect Description	Criterion	Drawing Specification
Chip	Chip in cross over area	<p>1) Reject - if the chip causes crossover dot to be exposed</p> <p>2) Chip on outside edge of the glass plate but is greater than 50% of glass thickness at crossover dot is reject able.</p>	
Chip	Chip in contact pad area	Accept if:- a) $X \leq 2.0\text{mm}$ b) $Y \leq 0.5\text{mm}$ c) Z disregard	
	Chip in non-contact pad area	Accept if:- a) $X \leq 6.0\text{mm}$ b) $Y \leq 1.0\text{mm}$ c) Z disregard	
	Chip in perimeter seal area	Accept if:- a) $Y \leq 1/3$ of perimeter seal width (W) b) $X \leq 3.0\text{mm}$ c) Z disregard d) X and Y not touch crossover dot	
Corner Chip	Corner chip within seal area	Accept if:- a) $X \leq 1/3$ of perimeter seal width (W) b) $Y \leq 1/3$ of perimeter seal width (W) c) Z disregard	



Defect Category	Defect Description	Criterion	Drawing Specification
	Corner chip not effecting contact pad / ITO	Accept if:- a) $XY \leq 4\text{mm}^2$ AND b) $Y \leq D$ and $X \leq 2.0\text{mm}$ c) Z disregard	
	Corner chip effecting contact pad / ITO	A) Accept if:- a) $XY \leq 4\text{mm}^2$ AND b) $Y \leq D$ and $X \leq 2.0\text{mm}$ B) Accept if:- a) $X1 \leq 2.0\text{mm}$ b) $Y1 \leq 0.5\text{mm}$ Z disregard	
Glass flare	A thin layer of glass flare at contact area	Accept if:- a) Flare thickness $\leq \frac{1}{4}W$ when $W \leq 3\text{mm}$ b) Flare thickness $\leq 1\text{mm}$ when $W > 3\text{mm}$ W: Contact ledge width	
Glass burr	A rough edge(s) left along the scribing edge (i.e. along the edges of display)	Reject – if the burr cause undersize or oversize of the LCD	Refer to LCD Physical Dimension Drawing
Rainbow	Colored ring in sharp blotches observed	Reject – if 3 or more colored rings in sharp blotches of color are observed. (Limit samples should be used when applicable)	



Defect Category	Defect Description	Criterion	Drawing Specification
Discoloration		Reject - if the discolorations enter the active viewing area of LCD. Color of the LCD shall follow product specification as specified in the manufacturing specification	
Air Void	LC does not fulfill the display	Reject	
Fill end contamination	Discoloration at end seal area	Reject if discoloration exceeded the baffle (for display with baffle) or viewing area (for display without baffle)	

12.2.3 POLARIZER DEFECTS

Defect Category	Defect Description	Criterion	Drawing Specification
Polarizer defect	Polarizer coverage	1- Polarizer should cover effective viewing area of display. 2- It is acceptable if perimeter seal bolder at all sides could be seen. 3- It is acceptable if polarizer attaching position meeting the tolerance mentioned in the drawing. 4- It is reject able if polarizer edge jagged and not even	Refer to LCD Physical Dimension Drawing
	Polarizer Peeling / delamination	1- Reject if any edge or corner of the polarizer is lifted up or not adheres to the glass	
	Polarizer Scratches	1- Any scratch should be acceptable if it is not visible from viewing distance at head of position 2- Polarizer scratch in viewing area is reject able if it is visible from the specified viewing distance 3- Defect, which is visible under surface glare, should be disregard	



Defect Category	Defect Description	Criterion	Drawing Specification																				
	Polarizer damage	1-Stain mark or depression in front polarizer surface should be acceptable if it is not visible from viewing distance at head on position. 2-Defect, which is visible under surface glare, should be disregard																					
	Polarizer bubble / Foreign material	<table border="1"> <thead> <tr> <th rowspan="2">Zone / Dimension</th> <th colspan="3">Acceptable No.</th> </tr> <tr> <th>A</th> <th>B</th> <th>C</th> </tr> </thead> <tbody> <tr> <td>$D \leq 0.30\text{mm}$</td> <td>NC</td> <td>NC</td> <td rowspan="4">NC if the Polarizer not lifted up/ peel off</td> </tr> <tr> <td>$D \leq 0.50\text{mm}$</td> <td>2</td> <td>NC</td> </tr> <tr> <td>$0.50 < D \leq 0.60\text{mm}$</td> <td>1</td> <td>2</td> </tr> <tr> <td>$D > 0.60\text{mm}$</td> <td>0</td> <td>0</td> </tr> </tbody> </table> <p>NC: No count D: Mean Diameter of Defect</p> <p>3 are the totally permissible numbers of bubble</p>	Zone / Dimension	Acceptable No.			A	B	C	$D \leq 0.30\text{mm}$	NC	NC	NC if the Polarizer not lifted up/ peel off	$D \leq 0.50\text{mm}$	2	NC	$0.50 < D \leq 0.60\text{mm}$	1	2	$D > 0.60\text{mm}$	0	0	<p>$D = (A + B)/2$</p>
Zone / Dimension	Acceptable No.																						
	A	B	C																				
$D \leq 0.30\text{mm}$	NC	NC	NC if the Polarizer not lifted up/ peel off																				
$D \leq 0.50\text{mm}$	2	NC																					
$0.50 < D \leq 0.60\text{mm}$	1	2																					
$D > 0.60\text{mm}$	0	0																					

12.2.4 ELECTRICAL TEST DEFECTS

Defect Category	Defect Description	Criterion	Drawing Specification
Missing common	Part of the pattern does not light up	Reject	
Missing segment	One or few segment does not light up	Reject	
Common-common short	Common and common connected	Reject	
Segment-segment short	Segment and segment connected	Reject	
Common – segment short	Common and segment connected	Reject	
Wrong viewing angle	Wrong viewing angle	Reject if display viewing angle not conform to customer requirement	
Metal residue	Extra spot lights up at the border of the segment.	Accept if $\leq 0.20\text{mm}$ (mean diameter)	
Slow response	Response of the display on one side slower than the other side	Reject if it is visible at 30cm distance	



Defect Category	Defect Description	Criterion		Drawing Specification
Pin Hole	Pin hole / void at light up segment	Zone / Dimension	Acceptable No.	
		Located inside single pixel/dot:- $(X + Y)/2 \leq 0.20\text{mm}$	- 1 per pixel/dot - 3 per display (Active Area)	
		Laid over the plural pixel/dots: $(X + Y)/2 \leq 0.20\text{mm}$	- 1 per pixel/dot - 3 per display (Active Area)	
		<i>(3/4 or larger part of dot area has to be effective for display)</i>		
Deformed display dot	Lacked deformation	Accept if: i) $X \leq 0.15$ and ii) $Y \leq 0.15$		
	Added deformation	Accept if: i) $X < 0.02$ and ii) $Y < 0.02$		
Reverse twist/tilt	Segment are darker or clearer than other area of the same segment	Reject		
Misalignment	Segment fatter or smaller or extra segment	Reject if $> 10\%$ of designed segment width and visible at 30cm distance		
Segment Smearing	Light up segment smear	Reject		
Dim segment	Display shows poor contrast at pre set voltage	Reject		

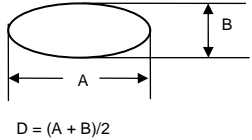

12.2.5 BLACK SPOT, WHITE SPOT AND FOREIGN MATERIAL (SOLID FIGURE)

Defect Category	Defect Description	Criterion			Drawing Specification	
Black Spot, White Spot and Foreign Material	Black Spot, White Spot and Foreign Material	Zone / Dimension	Acceptable No.			
			A	B	C	
		$D \leq 0.10\text{mm}$	NC	NC	NC	
		$0.10 < D \leq 0.15\text{mm}$	3	3	NC	
		$0.15 < D \leq 0.25\text{mm}$	1	2	NC	
		$0.25 < D \leq 0.35\text{mm}$	1	1	NC	
		$D > 0.35 \text{ mm}$	0	0	NC	
		NC: No count D: Mean Diameter of Defect				

NOTE: The 1/3 or larger parts of individual dot has to be lighted on.
The solid figure is that the defect has clear-cut outline at the optimum driving condition in both positive and negative, of which size does not change when the contrast changes.

12.2.6 BLACK SPOT, WHITE SPOT AND FOREIGN MATERIAL (FADED FIGURE)

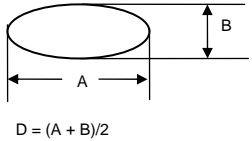
Defect Category	Defect Description	Criterion			Drawing Specification	
Black Spot, White Spot and Foreign Material	Black Spot, White Spot and Foreign Material	Zone / Dimension	Acceptable No.			
			A	B	C	
		$D \leq 0.60\text{mm}$	NC	NC	NC	
		$0.60 < D \leq 0.70\text{mm}$	3		NC	
		$0.70 < D \leq 0.80\text{mm}$	1		NC	
		$D > 0.80 \text{ mm}$	0		NC	
NC: No count D: Mean Diameter of Defect						

NOTE: Faded figure means that the defects has unclear outline at the optimum driving condition in both positive and negative, of which size seems to change when the contrast changes.



12.2.7 LINE SHAPE AND SCRATCHES

Defect Category	Defect Description	Criterion					Drawing Specification
Line shape and scratches	Line shape and scratches	Zone /Dimension		Acceptable No.			
		X	Y	A	B	C	
		NC	≤ 0.03mm	NC	NC	NC	
		≤ 2 mm	≤ 0.05mm	1	1	NC	
		≤ 1 mm	≤ 0.10mm	1	2	NC	
		NC	≥ 0.10mm	Due to (1) round defect			

NOTE: Length is X and Width is Y.

REMARK:

i) Total amount of spot defects including round and linear – A total of 5 permissible numbers of defects in Zone A & B including above (12.2.5), (12.2.6), (12.2.7). Regardless of number of defects, the minimum distance between individual defects have to be 5mm or larger.

ii) All the other items of inspection that are not included herein must be determined by the “Limit Standard” sample, which were occasionally set up with the mutual consent of both parties. In every case of the items set up with the Limit Standard, the Limit Standard always takes precedence over the other means of definition.



13. Precaution for using LCM

1. Liquid Crystal Display (LCD)

LCD is made up of glass, organic sealant, organic fluid and polymer based polarizers. The following precautions should be taken when handling.

- a) Keep the temperature within the range of use and storage. Excessive temperature and humidity could cause polarization degradation, polarizer peel off or bubble.
- b) Do not contact the exposed polarizer with anything harder than HB pencil lead. To clean dust off the display surface, wipe gently with cotton, chamois or other soft material soaked in petroleum benzine.
- c) Wipe off saliva or water drops immediately. Contact with water over a long period of time may cause polarizer deformation or colour fading, while an active LCD with water condensation on its surface will cause corrosion of ITO electrodes.
- d) Glass can be easily chipped or cracked from rough handling, especially at corners and edges.
- e) Do not drive LCD with DC voltage.

2. Liquid Crystal Display Modules.

2.1 Mechanical Considerations

LCM are assembled and adjusted with a high degree of precision. Avoid excessive shocks and do not make any alterations or modification. The following should be noted.

- a) Do not tamper in any way with the tabs on the metal frame.
- b) Do not modify the PCB by drilling extra holes, changing its outline, moving its component or modifying its pattern.
- c) Do not touch the elastomer connector, especially insert a backlight panel (for example, EL)
- d) When mounting a LCM make sure that the PCB is not under any stress such as bending or twisting. Elastomer contacts are very delicate and missing pixels could result from slight dislocation of any of the elements.

- e) Avoid pressing on the metal bezel, otherwise the elastomer connector could be deformed and lose contact, resulting in missing pixels.

2.2 Static Electricity

LCM contains CMOS LSI's and the same precaution for such devices should apply, namely

- a) The operator should be grounded whenever he/she comes into contact with the module. Never touch any of the conductive parts such as the LSI pads, the copper leads on the PCB and the interface terminals with any parts of the human body.
- b) The modules should be kept in antistatic bags or other containers to static for storage.
- c) Only properly grounded soldering irons should be used.
- d) If an electric screwdriver is used, it should be well grounded and shielded from commutator spark.
- e) The normal static prevention measures should be observed for work clothes and working benches, the latter conductive (rubber) mat is recommended.
- f) Since dry air is inductive to statics, a relative humidity of 50-60% is recommended.

2.3 Soldering

- a) Solder only to the I/O terminals.
- b) Use only soldering irons with proper grounding and no leakage.
- c) Soldering temperature: 280 °C
- d) Soldering time: 3 to 4 sec
- e) Use eutectic solder with resin flux fill.
- f) If flux is used, the LCD surface should be covered to avoid flux spatters. Flux residue should be removed afterwards.



2.4 Operation

- a) The contrast can be adjusted by varying the LCD driving voltage V_0
- b) Driving voltage should be kept within specified range, excess voltage shortens display life.
- c) Response time increases with decrease in temperature.
- d) Display may turn black or dark blue at temperature above its operational range, this is (however not pressing on the viewing area) may cause the segments to appear “fractured”.
- e) Mechanical disturbance during operation (such as pressing on the viewing area) may cause the segments to appear “fractured”.

2.5 Storage

If any fluid leaks out of the damaged glass cell, wash off any human part that comes into contact with soap and water. Never swallow the fluid. The toxicity is extremely low but caution should be exercised at all the time.

2.6 Limited Warranty

Unless otherwise agreed between Crystal Clear Technology and customer, Crystal Clear Technology will replace or repair any of its LCD and LCM which is found to be defective electrically and visually when inspected in accordance with Crystal Clear Technology acceptance standards, for a period of one year from date of shipment. Confirmation of such date shall be based on freight documents. The warranty liability of Crystal Clear Technology is limited to repair and/or replacement on the terms set forth above. Crystal Clear Technology will not be responsible for any subsequent or consequential events.

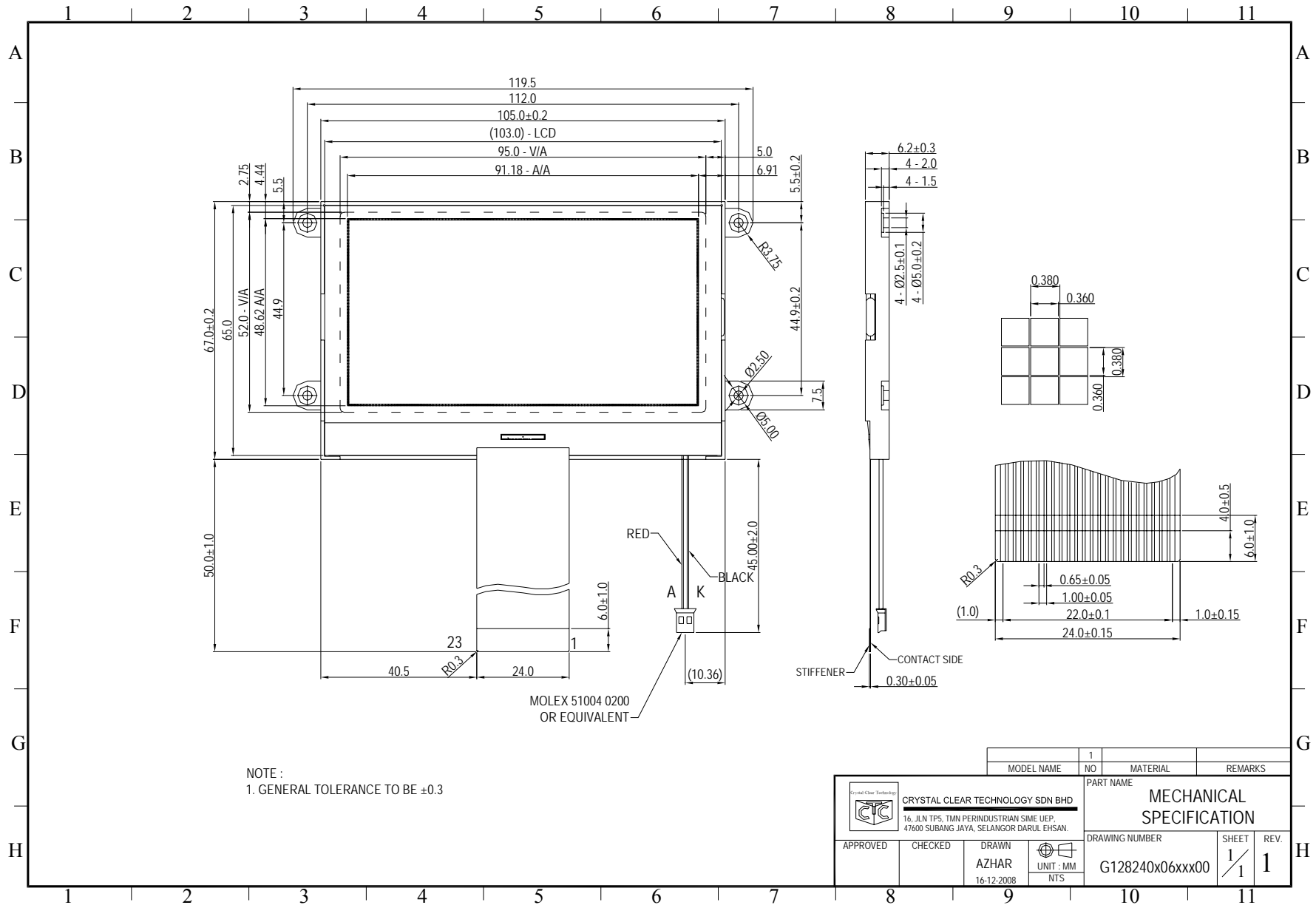

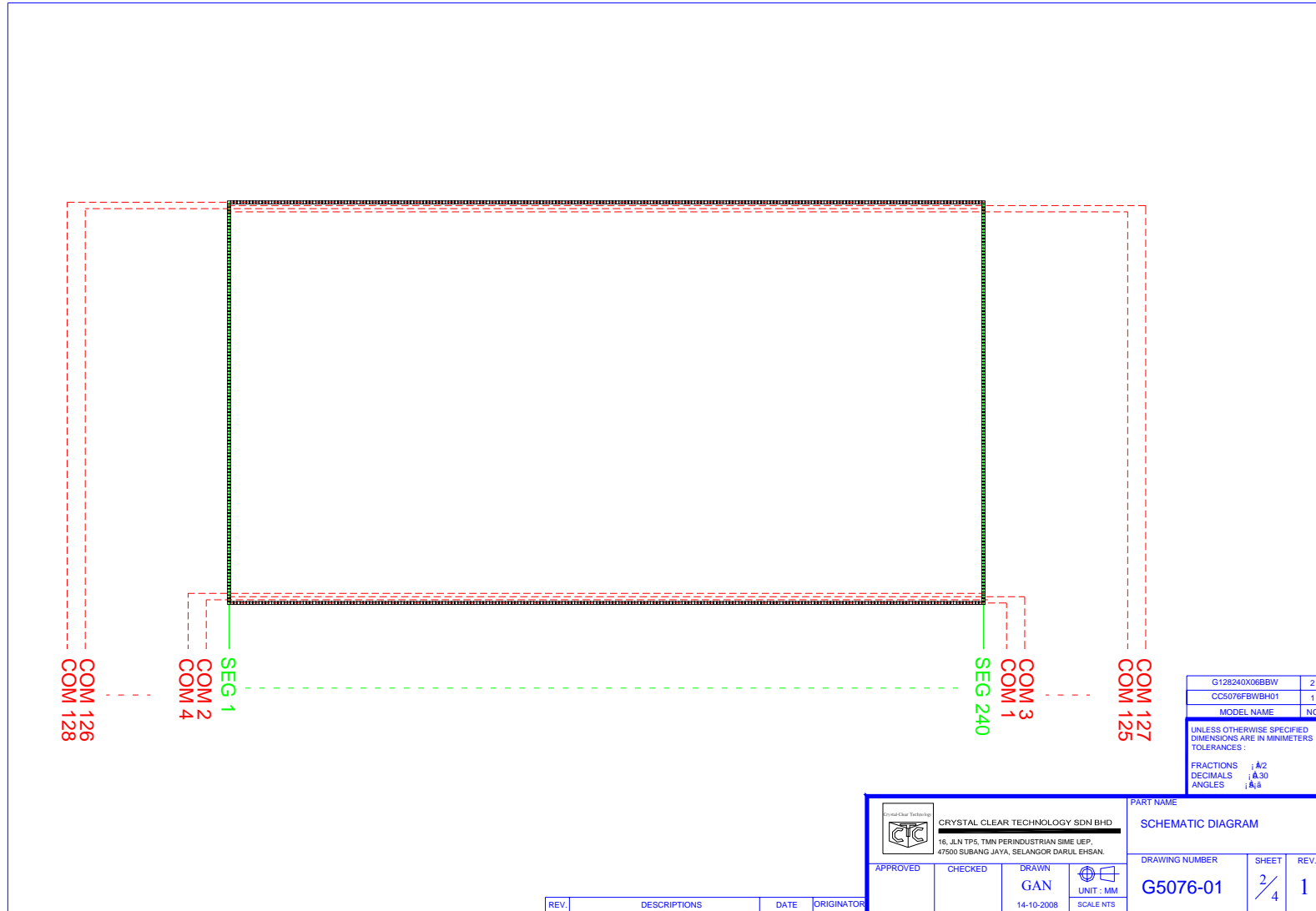

LCD Segment and Common Layout



Crystal Clear Technology
16 Jalan TP5—Taman Perindustrian Sime UEP
47600 Subang Jaya—Selangor DE
Malaysia