

Crystal Clear Technology

Product Specification

G64128X23XXW00

(REPLACEMENT FOR G64128X07XXW00)

Crystal Clear Technology sdn. bhd.

16Jalan TP5—Taman Perindustrian Sime UEP
47600 Subang Jaya—Selangor DE
Malaysia. T: +603 80247099 F: +603 80247098



1.0	Table of Contents	Page
1.	Table of Contents	1
2.	Record of revision	2
3.	General specification	3
4.	Absolute maximum ratings	4
5.	Electrical characteristics	4
6.	Environmental and Reliability Requirement	5
7.	LCD specification	6 ~ 8
8.	Interface	9
9.	Functional Description	10 ~ 14
10.	Instructions	15
11.	Power Supply	16
12.	Block Diagram	16
13.	Quality Assurance	17 ~22
14.	Precautions in use LCM	23 ~ 24
15.	Mechanical Specification	25



2.0 Record of revision

Rev	Date	Item	Page	Comment	Originator	Checked By
1.0	01/12/10			Initial Release	Thorn	Azhar
2.0	08/04/10	3	3	Update Module Numbering	Chong	Azhar



3.0 General specification

Display format: Graphics 128 (w) x 64 (h) dots

Dot size: 0.48 (w) x 0.48 (h) mm

Dot pitch: 0.52 (w) x 0.52 (h) mm

View area: 70.7 (w) x 38.8 (h) mm

Active area: 66.52 (w) x 33.24 (h) mm

General dimensions: 76.10 (w) x 53.80 (h) x 6.0 (t) mm

Controller/Driver: ST7565P or equivalent

Interface: Parallel

Driving method: 1/64 duty, 1/9 bias

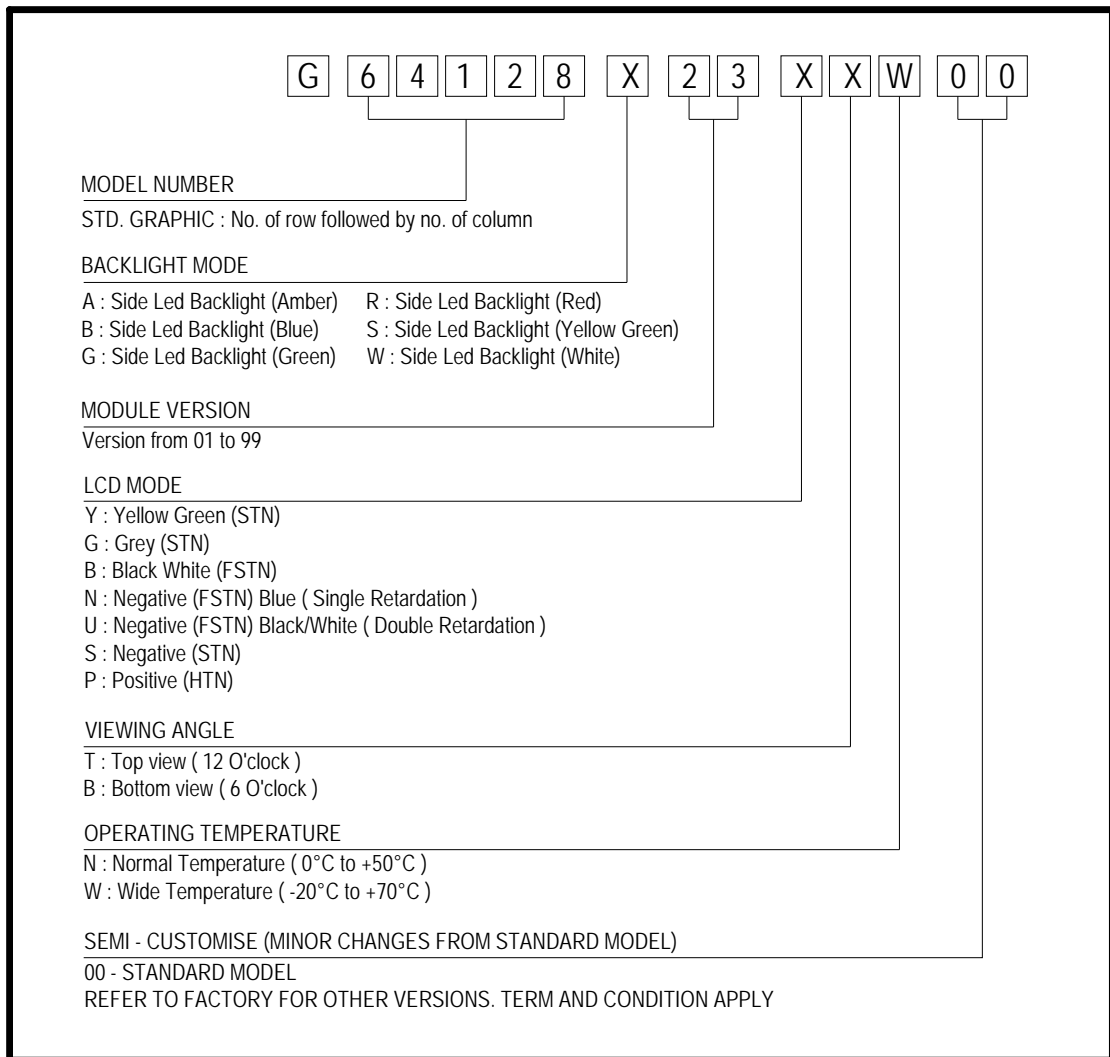

**4.0 Absolute maximum rating (at V_{SS} = 0V, Ambient temperature = 25°C)**

NO	ITEM	SIMBOL	MIN	MAX	UNIT
1.	Operating Voltage Range	V _{DD}	1.8	3.3	V
2.	Supply Voltage Range	V _{LCD}	-	10.2	V
3.	Input Voltage	V _{IN}	-	-	V
4.	Operating Temperature	T _{op}	Refer page 3		°C
5.	Storage Temperature	T _{st}	Refer page 3		°C

5.0 Electrical characteristics

NO	ITEM	SYMBOL	CONDITION	MIN	TYP	MAX	UNIT
1.	Power Supply voltage (Logic)	V _{DD} - V _{SS}	-	2.7	3.0	3.3	V
2.	Power Supply voltage for LCD	V ₀ - V _{SS}	25°C	9.6±5%			V
3.	Current Supply	I _{DD}	V _{DD} - V _{SS} = 3.0V	-	2.06	3.0	mA

*Note: Point 2, power supply voltage for LCD functions as a reference voltage. CCT is to set samples limit for contrast programming at factory level. This is to ensure consistent contrast ratio for all production LCD.

5.1 Backlight Option

NO	Color	Forward Voltage(V)			Forward Current(mA)			Min Brightness(cd/m2)*
		Min	Typ	Max	Min	Typ	Max	
1.	White	-	4.0	-	-	60	80	60
2.	Blue	-	4.0	-	-	60	80	30
3.	Green	6.2	6.6	7.0	-	60	-	150
4.	Yellow Green	-	4.0	-	-	60	120	40
5.	Amber	-	4.0	-	-	60	120	60
6.	Red	-	4.0	-	-	60	120	60

*Note : 1. Brightness Measured at backlight surface
 2. On LCD surface, brightness is only about 10% to 15 % of backlight brightness.
 3. Lifetime of backlight: For YG, Red, Amber = 50k hrs.
 For White, Blue, Green = 20K hrs.

**6.0 Environmental and Reliability requirements**

NO	ITEM	CONDITION
1.	Operating Temperature	Refer page 3
2.	Storage Temperature	Refer page 3
3.	Operating Humidity	Up to 90%RH
4.	Lifetime	50000 HOURS (excluding backlight)

Note: The background on LCD has the possibility to be changed in different temperature range.

TEST DESCRIPTION	TEST PARAMETERS	LCD	LCM
Temperature Cycle Operation	1 cycle = 0°C for 30 minutes, +70°C for 30minutes. Perform 10 cycles. LCM in operation.	N/A	Yes
Temperature Cycle Storage	1 cycle = -20°C for 30 minutes, +70°C for 30minutes. Perform 10 cycles. LCM in non-operation.	N/A	Yes
Boiling	LCD without polarizer. Boil LCD at 100°C @ 100% RH for 40 hours	Yes	N/A
Humidity Operation	+40°C at 90~95% RH for 250hours. *Applicable when fail boiling test	N/A	Yes

Note: Applicable to prototype and pre-production.



7.0 LCD specification

7.1 Electro-optical characteristics (at ambient temperature = 25°C)

NO	ITEM	SYMBOL	CONDITION	LCD TYPE							REF.
				STN YG	STN GREY	STN -VE BLUE/PURPLE	FSTN +VE B/W	FSTN -VE BLUE	FSTN -VE TRUE B/W	FSTN -VE TRI AXIS	
1	Operating Voltage (Volt)	V_{LCD}	$\theta = 0$ $Cr = \max$	9.6 ± 5%							7.1.1
2	Viewing Angle (Deg)	θ_{x1}	$CR \geq 2$ $V_{LCD} = 9.6V$	+25	+20	+35	+25	+35	+35	+40	7.1.2
		θ_{x2}		-25	-20	-35	-25	-35	-40	-40	
		θ_{y1}		-30	-25	-35	-30	-35	-35	-50	
		θ_{y2}		+30	+25	+35	+30	+35	+35	+30	
3	Contrast Ratio	CR	$\theta = 0^0$ $V_{LCD} = 9.6V$	3.0	2.3	6.0	3.0	6.0	20	20	7.1.3
4	Response Time (msec)	Rise Time (Tr)	$\theta = 0^0$	200							7.1.4
		Decay Time (Td)	$\theta = 0^0$	250							

Note:

1. Viewing angle data is based on bottom view product by default. Should it be a top view product, values are then swap.
2. Contrast ratio is based on typical data when using white colour as backlight.
3. Equipment Used Eldim; Ez Contrast 120R , Spot Size = 2mm

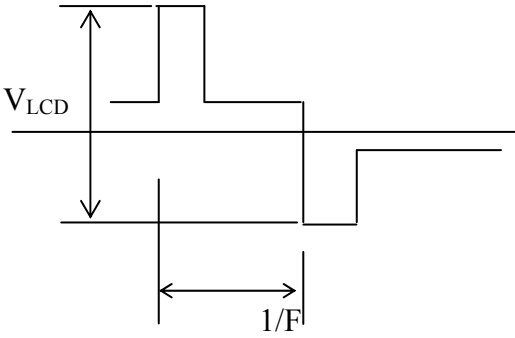
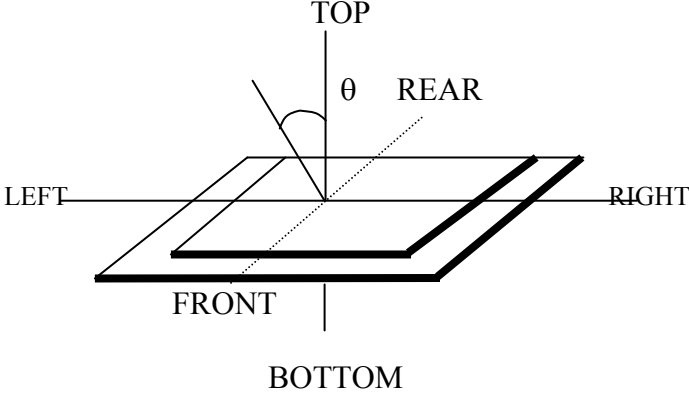
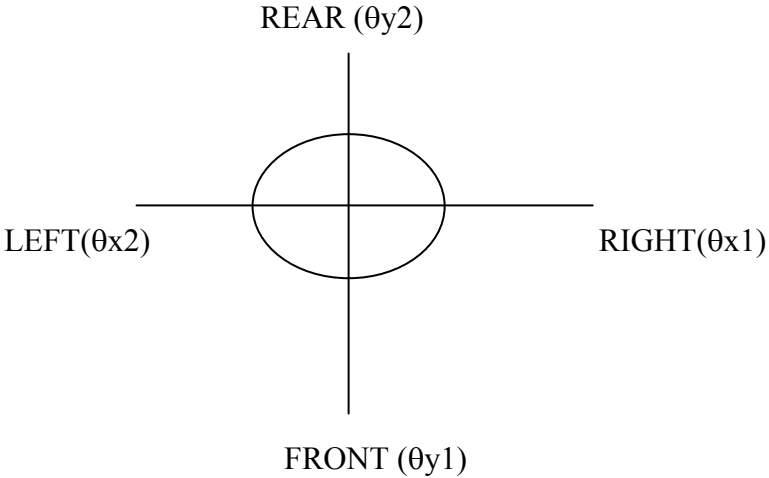

NO	CHARACTERISTICS	DEFINITIONS
7.1.1	Definition of Operating Voltage (V_{LCD})	 <p>V_{LCD} : Operating Voltage F : Frame Frequency</p>
7.1.2	Definition of Viewing Angle	 

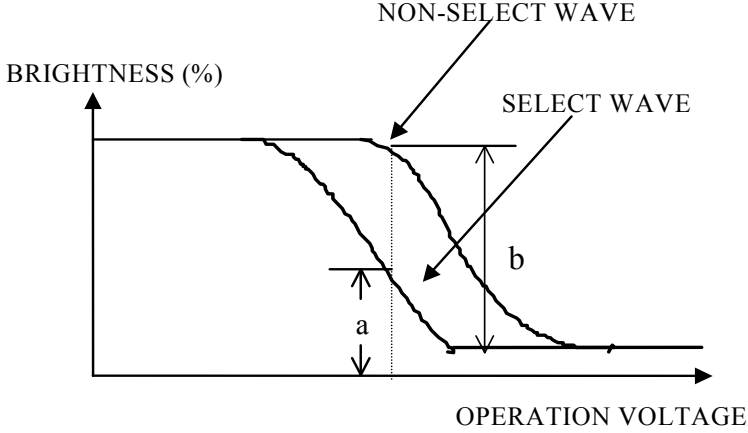
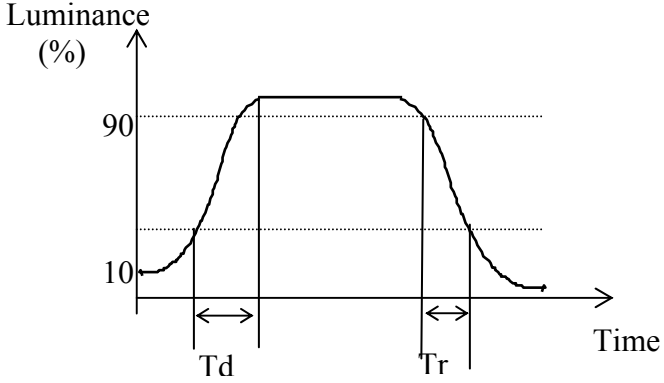

<p>7.1.3</p>	<p>Definition of Contrast Ratio</p>	 <p>Contrast Ratio = $\frac{\text{Brightness of non-selected state (b)}}{\text{Brightness of selected state (a)}}$</p> <p>Conditions</p> <ul style="list-style-type: none">(a) Operating Voltage: V_{LCD}(b) Temperature: $25^{\circ}C$(c) Viewing Angle, $\theta = 0^{\circ}$
<p>7.1.4</p>	<p>Response Time</p>	 <p>T_r: Measured between 10% and 90% of LCD segment maximum response with V_{ON}.</p> <p>T_d: With voltage switches to zero and the instant LCD segment reaches 10% of its maximum response.</p>



8.0 Interface

8.1	<i>Controller/Driver</i>	ST7565P	
8.2	<i>Duty Cycle</i>	1/64	
8.3	<i>Pin out Assignments</i>		
	Pin No	Symbol	Description
	1	Vss	Ground
	2	Vdd	Logic Power Supply
	3	Vout	Booster Output Voltage
	4	/Res	Read / Write execution control pin
	5	/CS1	Chip Select execution control pin
	6	A0	Data or Command execution control pin
	7	WR	Read / Write execution control pin
	8	E	Enable execution control pin
	9	D0	8-bit MPU bus via the 8-bit bi-directional bus
	10	D1	8-bit MPU bus via the 8-bit bi-directional bus
	11	D2	8-bit MPU bus via the 8-bit bi-directional bus
	12	D3	8-bit MPU bus via the 8-bit bi-directional bus
	13	D4	8-bit MPU bus via the 8-bit bi-directional bus
	14	D5	8-bit MPU bus via the 8-bit bi-directional bus
	15	D6	8-bit MPU bus via the 8-bit bi-directional bus
	16	D7	8-bit MPU bus via the 8-bit bi-directional bus
	17	A	Backlight Anode Terminal
	18	K	Backlight Cathode Terminal



9.0 Functional Descriptions

9.1 Read/Write timing characteristics

System Bus Read/Write Characteristics (For the 6800 Series MPU)

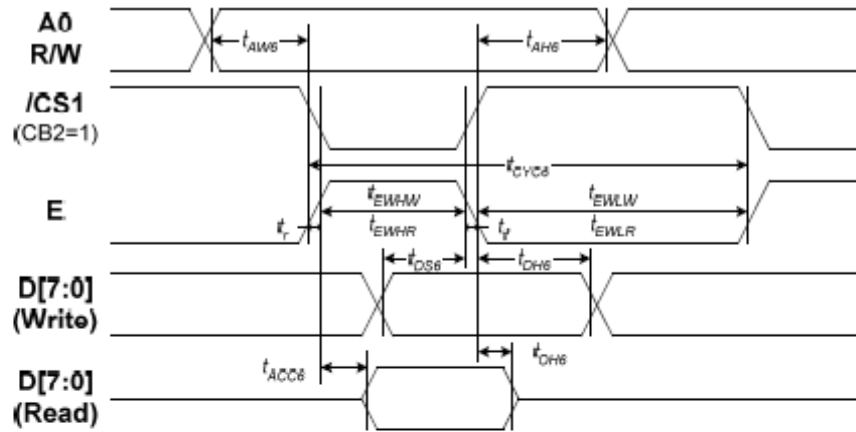

Figure 38

Table 27

(V_{DD} = 3.3V, T_a = -30 to 85°C)

Item	Signal	Symbol	Condition	Rating		Units
				Min.	Max.	
Address hold time	A0	t_{AHS}		0	—	ns
Address setup time		t_{AWS}		0	—	
System cycle time		t_{CYCS}		240	—	
Enable L pulse width (WRITE)	E	t_{EWLW}		80	—	
Enable H pulse width (WRITE)		t_{EWHW}		80	—	
Enable L pulse width (READ)		t_{EWLR}		80	—	
Enable H pulse width (READ)		t_{EWHR}		140	—	
WRITE Data setup time	D0 to D7	t_{DSS}		40	—	
WRITE Address hold time		t_{OHS}		0	—	
READ access time		t_{ACCS}	$C_L = 100 \text{ pF}$	—	70	
READ Output disable time		t_{OHS}	$C_L = 100 \text{ pF}$	5	50	



(V_{DD} = 2.7V, T_a = -30 to 85°C)

Item	Signal	Symbol	Condition	Rating		Units
				Min.	Max.	
Address hold time	A0	t _{AH5}		0	—	ns
Address setup time		t _{AW5}		0	—	
System cycle time		t _{CYC5}		400	—	
Enable L pulse width (WRITE)	E	t _{EWLW}		220	—	
Enable H pulse width (WRITE)		t _{EWHW}		180	—	
Enable L pulse width (READ)		t _{EWLR}		220	—	
Enable H pulse width (READ)		t _{EWHR}		180	—	
WRITE Data setup time	D0 to D7	t _{DS5}		40	—	
WRITE Address hold time		t _{DH5}		0	—	
READ access time		t _{ACC5}	C _L = 100 pF	—	140	
READ Output disable time		t _{OH5}	C _L = 100 pF	10	100	

Table 29

(V_{DD} = 1.8V, T_a = -30 to 85°C)

Item	Signal	Symbol	Condition	Rating		Units
				Min.	Max.	
Address hold time	A0	t _{AH5}		0	—	ns
Address setup time		t _{AW5}		0	—	
System cycle time		t _{CYC5}		640	—	
Enable L pulse width (WRITE)	E	t _{EWLW}		360	—	
Enable H pulse width (WRITE)		t _{EWHW}		280	—	
Enable L pulse width (READ)		t _{EWLR}		360	—	
Enable H pulse width (READ)		t _{EWHR}		280	—	
WRITE Data setup time	D0 to D7	t _{DS5}		80	—	
WRITE Address hold time		t _{DH5}		0	—	
READ access time		t _{ACC5}	C _L = 100 pF	—	240	
READ Output disable time		t _{OH5}	C _L = 100 pF	10	200	

*1 The input signal rise time and fall time (tr, tf) is specified at 15 ns or less. When the system cycle time is extremely fast, (tr + tr) ≤ (t_{CYC5} - t_{EWLW} - t_{EWHW}) for (tr + tr) ≤ (t_{CYC5} - t_{EWLR} - t_{EWHR}) are specified.

*2 All timing is specified using 20% and 80% of V_{DD} as the reference.

*3 t_{EWLW} and t_{EWLR} are specified as the overlap between CS1 being "L" (CS2 = "H") and E.

Read/Write characteristics (6800 series MPU)



System Bus Read/Write Characteristics (For the 8080 Series MPU)

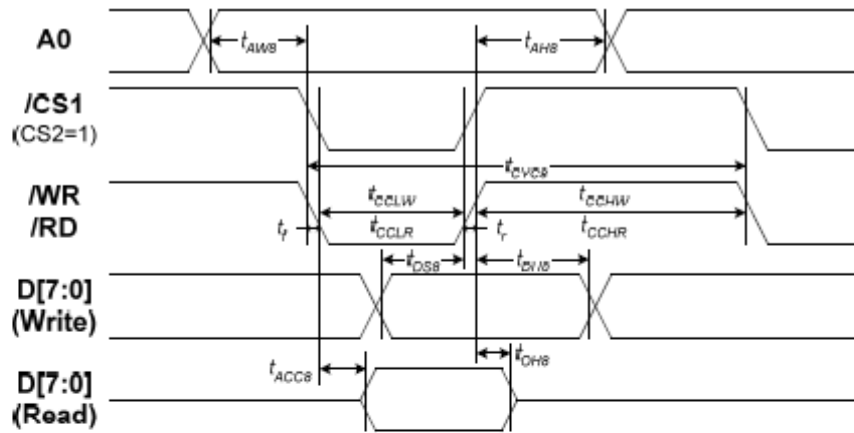

Figure 37

Table 24

(V_{DD} = 3.3V, T_a = -30 to 85°C)

Item	Signal	Symbol	Condition	Rating		Units
				Min.	Max.	
Address hold time	A0	t _{AHS}		0	—	Ns
Address setup time		t _{AWS}		0	—	
System cycle time		t _{CYCS}		240	—	
Write L pulse width	/WR	t _{CCLW}		80	—	
Write H pulse width		t _{CCHW}		80	—	
Read L pulse width	/RD	t _{CCLR}		140	—	
Read H pulse width		t _{CCHR}		80	—	
Write Data setup time	D0 to D7	t _{DSB}		40	—	
Write Address hold time		t _{DWB}		0	—	
Read access time		t _{ACC8}	CL = 100 pF	—	70	
Read Output disable time		t _{OHB}	CL = 100 pF	5	50	



(V_{DD} = 2.7V, T_a = -30 to 85°C)

Item	Signal	Symbol	Condition	Rating		Units
				Min.	Max.	
Address hold time	A0	t _{AH8}		0	—	ns
Address setup time		t _{AW8}		0	—	
System cycle time		t _{CY8}		400	—	
Write L pulse width	WR	t _{CLW}		220	—	
Write H pulse width		t _{CHW}		180	—	
Read L pulse width	RD	t _{CLR}		220	—	
Read H pulse width		t _{CHR}		180	—	
Write Data setup time	D0 to D7	t _{DS}		40	—	
Write Address hold time		t _{HS}		0	—	
Read access time		t _{ACC}	C _L = 100 pF	—	140	
Read Output disable time		t _{OH}	C _L = 100 pF	10	100	

Table 26

(V_{DD} = 1.8V, T_a = -30 to 85°C)

Item	Signal	Symbol	Condition	Rating		Units
				Min.	Max.	
Address hold time	A0	t _{AH8}		0	—	ns
Address setup time		t _{AW8}		0	—	
System cycle time		t _{CY8}		640	—	
Write L pulse width	WR	t _{CLW}		360	—	
Write H pulse width		t _{CHW}		280	—	
Read L pulse width	RD	t _{CLR}		360	—	
Read H pulse width		t _{CHR}		280	—	
Write Data setup time	D0 to D7	t _{DS}		80	—	
Write Address hold time		t _{HS}		0	—	
Read access time		t _{ACC}	C _L = 100 pF	—	240	
Read Output disable time		t _{OH}	C _L = 100 pF	10	200	

*1 The input signal rise time and fall time (t_r, t_f) is specified at 15 ns or less. When the system cycle time is extremely fast, (t_r + t_f) ≤ (t_{CY8} - t_{CLW} - t_{CHW}) for (t_r + t_f) ≤ (t_{CY8} - t_{CLR} - t_{CHR}) are specified.

*2 All timing is specified using 20% and 80% of V_{DD} as the reference.

*3 t_{CLW} and t_{CLR} are specified as the overlap between /CS1 being "L" (CS2 = "H") and /WR and /RD being at the "L" level.

Read/Write characteristics (8080 series MPU)



9.2 Application Circuits

9.2.1 6800 – Series Parallel Interface

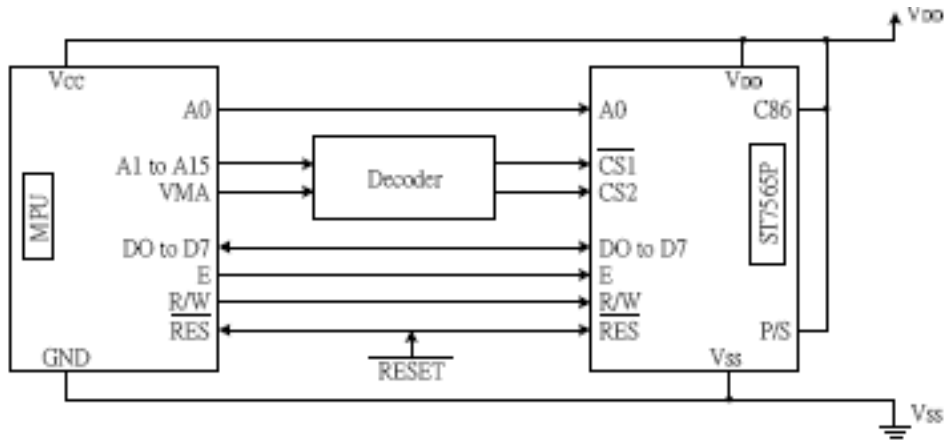

9.2.2 8080 – Series Parallel Interface

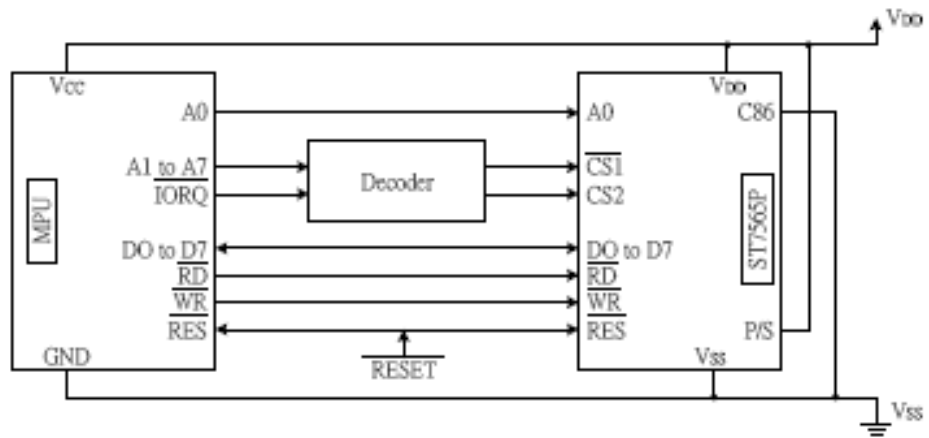



10. Instruction Set

Command	Command Code										Function		
	A0	/RD	/WR	D7	D6	D5	D4	D3	D2	D1		D0	
(1) Display ON/OFF	0	1	0	1	0	1	0	1	1	1	0	1	LCD display ON/OFF 0: OFF, 1: ON
(2) Display start line set	0	1	0	0	1	Display start address						Sets the display RAM display start line address	
(3) Page address set	0	1	0	1	0	1	1	Page address				Sets the display RAM page address	
(4) Column address set upper bit	0	1	0	0	0	0	1	Most significant column address				Sets the most significant 4 bits of the display RAM column address.	
Column address set lower bit	0	1	0	0	0	0	0	Least significant column address				Sets the least significant 4 bits of the display RAM column address.	
(5) Status read	0	0	1	Status				0	0	0	0	Reads the status data	
(6) Display data write	1	1	0	Write data								Writes to the display RAM	
(7) Display data read	1	0	1	Read data								Reads from the display RAM	
(8) ADC select	0	1	0	1	0	1	0	0	0	0	0	1	Sets the display RAM address SEG output correspondence 0: normal, 1: reverse
(9) Display normal/reverse	0	1	0	1	0	1	0	0	1	1	0	1	Sets the LCD display normal/reverse 0: normal, 1: reverse
(10) Display all points ON/OFF	0	1	0	1	0	1	0	0	1	0	0	1	Display all points 0: normal display 1: all points ON
(11) LCD bias set	0	1	0	1	0	1	0	0	0	1	0	1	Sets the LCD drive voltage bias ratio 0: 1/9 bias, 1: 1/7 bias (ST7565P)
(12) Read/modify/write	0	1	0	1	1	1	0	0	0	0	0	0	Column address increment At write: +1 At read: 0
(13) End	0	1	0	1	1	1	0	1	1	1	0	0	Clear read/modify/write
(14) Reset	0	1	0	1	1	1	0	0	0	1	0	0	Internal reset
(15) Common output mode select	0	1	0	1	1	0	0	0	0	*	*	*	Select COM output scan direction 0: normal direction 1: reverse direction
(16) Power control set	0	1	0	0	0	1	0	1	Operating mode			Select internal power supply operating mode	
(17) Vo voltage regulator internal resistor ratio set	0	1	0	0	0	1	0	0	Resistor ratio			Select internal resistor ratio(Rb/Ra) mode	
(18) Electronic volume mode set	0	1	0	1	0	0	0	0	0	0	0	1	Set the Vo output voltage electronic volume register
Electronic volume register set	0	1	0	0	0	Electronic volume value							
(20) Booster ratio set	0	1	0	1	1	1	1	1	1	0	0	0	select booster ratio 00: 2x,3x,4x 01: 5x 11: 6x
(21) Power saver													Display OFF and display all points ON compound command
(22) NOP	0	1	0	1	1	1	0	0	0	1	1	1	Command for non-operation
(23) Test	0	1	0	1	1	1	1	*	*	*	*	*	Command for IC test. Do not use this command



11. Power Supply

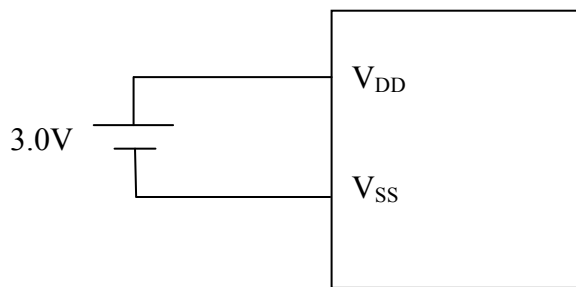

Note: This module must provide supply externally to VLCD pin (pin #7 – 15V Max). This module is not able to provide internal boosting.

12. Block Diagram

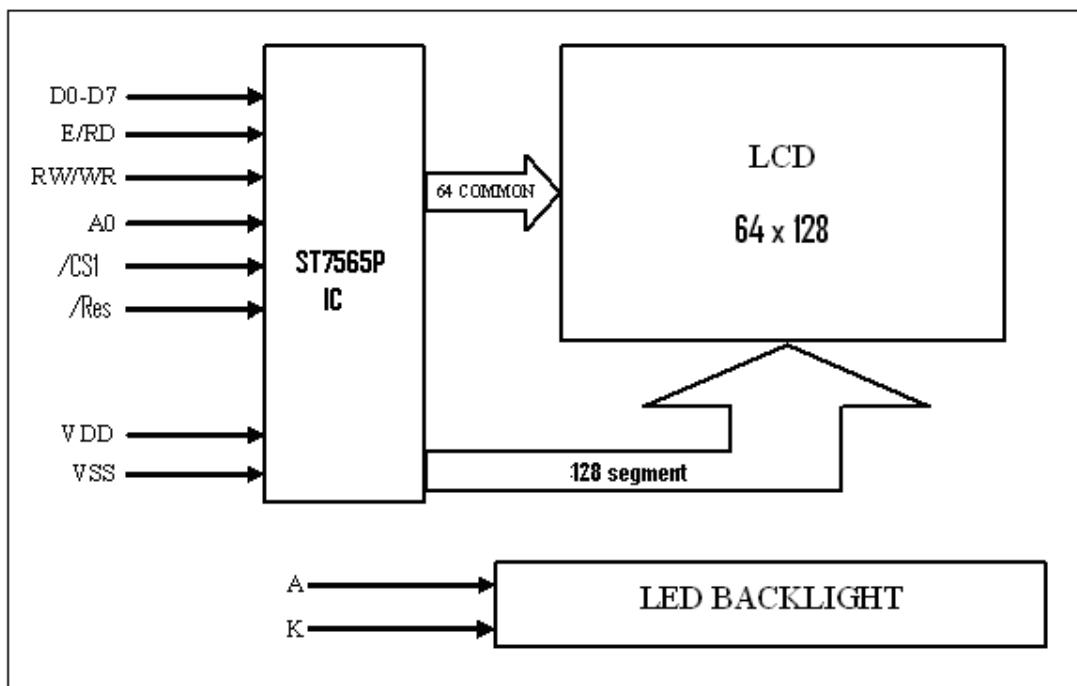



13.0 Quality Assurance

13.1 ZONE DEFINITION

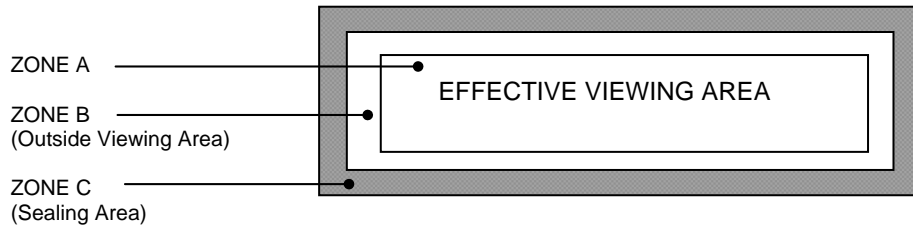

13.2 REJECTION CRITERIA

13.2.1 DIMENSIONAL DEFECTS

Defect Category	Defect Description	Criterion	Drawing Specification
Glass Size	Dimensions of LCD, do not conform to the drawing	Reject	Refer to LCD Physical Dimension Drawing
Perimeter Seal Extension	Perimeter seal epoxy enters the effective viewing area	Reject	
End Seal Size	Size of end seal does not meet drawing specification	Reject	Refer to LCD Physical Dimension Drawing

13.2.2 VISUAL DEFECTS

Defect Category	Defect Description	Criterion	Drawing Specification
Fracture	A type of glass breakage containing running cracks. Inspectors should attempt to remove it with fingernail. If removed, evaluate as chip	Reject – if the size is $\geq 30\%$ of the contact ledge width.	<p>The diagram shows a 3D perspective of a glass ledge. A crack is shown on the surface. A dimension line indicates the crack's length is $\leq 30\%$ of the ledge width. A note states 'Fracture does not penetrate through the whole glass thickness'.</p>



Defect Category	Defect Description	Criterion	Drawing Specification
Chip	Chip in cross over area	<p>1) Reject - if the chip causes crossover dot to be exposed</p> <p>2) Chip on outside edge of the glass plate but is greater than 50% of glass thickness at crossover dot is reject able.</p>	
Chip	Chip in contact pad area	<p>Accept if:-</p> <p>a) $X \leq 2.0\text{mm}$</p> <p>b) $Y \leq 0.5\text{mm}$</p> <p>c) Z disregard</p>	
	Chip in non-contact pad area	<p>Accept if:-</p> <p>a) $X \leq 6.0\text{mm}$</p> <p>b) $Y \leq 1.0\text{mm}$</p> <p>c) Z disregard</p>	
	Chip in perimeter seal area	<p>Accept if:-</p> <p>a) $Y \leq 1/3$ of perimeter seal width (W)</p> <p>b) $X \leq 3.0\text{mm}$</p> <p>c) Z disregard</p> <p>d) X and Y not touch crossover dot</p>	
Corner Chip	Corner chip within seal area	<p>Accept if:-</p> <p>a) $X \leq 1/3$ of perimeter seal width (W)</p> <p>b) $Y \leq 1/3$ of perimeter seal width (W)</p> <p>c) Z disregard</p>	



Defect Category	Defect Description	Criterion	Drawing Specification
	Corner chip not effecting contact pad / ITO	Accept if:- a) $XY \leq 4\text{mm}^2$ AND b) $Y \leq D$ and $X \leq 2.0\text{mm}$ c) Z disregard	
	Corner chip effecting contact pad / ITO	A) Accept if:- a) $XY \leq 4\text{mm}^2$ AND b) $Y \leq D$ and $X \leq 2.0\text{mm}$ B) Accept if:- a) $X1 \leq 2.0\text{mm}$ b) $Y1 \leq 0.5\text{mm}$ Z disregard	
Glass flare	A thin layer of glass flare at contact area	Accept if:- a) Flare thickness $\leq \frac{1}{4} W$ when $W \leq 3\text{mm}$ b) Flare thickness $\leq 1\text{mm}$ when $W > 3\text{mm}$ W: Contact ledge width	
Glass burr	A rough edge(s) left along the scribing edge (i.e. along the edges of display)	Reject – if the burr cause undersize or oversize of the LCD	Refer to LCD Physical Dimension Drawing
Rainbow	Colored ring in sharp blotches observed	Reject – if 3 or more colored rings in sharp blotches of color are observed. (Limit samples should be used when applicable)	



Defect Category	Defect Description	Criterion	Drawing Specification
Discoloration		Reject - if the discolorations enter the active viewing area of LCD. Color of the LCD shall follow product specification as specified in the manufacturing specification	
Air Void	LC does not fulfill the display	Reject	
Fill end contamination	Discoloration at end seal area	Reject if discoloration exceeded the baffle (for display with baffle) or viewing area (for display without baffle)	

13.2.3 POLARIZER DEFECT

Defect Category	Defect Description	Criterion	Drawing Specification
Polarizer defect	Polarizer coverage	1- Polarizer should cover effective viewing area of display. 2- It is acceptable if perimeter seal border at all sides could be seen. 3- It is acceptable if polarizer attaching position meeting the tolerance mentioned in the drawing. 4- It is reject able if polarizer edge jagged and not even	Refer to LCD Physical Dimension Drawing
	Polarizer Peeling / delamination	1- Reject if any edge or corner of the polarizer is lifted up or not adheres to the glass	
	Polarizer Scratches	1- Any scratch should be acceptable if it is not visible from viewing distance at head of position 2-Polarizer scratch in viewing area is reject able if it is visible from the specified viewing distance 3-Defect, which is visible under surface glare, should be disregard	
	Polarizer damage	1-Stain mark or depression in front polarizer surface should be acceptable if it is not visible from viewing distance at head on position. 2-Defect, which is visible under surface glare, should be disregard	



Defect Category	Defect Description	Criterion	Drawing Specification																												
	Polarizer bubble / Foreign material	<table border="1"> <thead> <tr> <th>Zone / Dimension</th> <th colspan="3">Acceptable No.</th> </tr> <tr> <th></th> <th>A</th> <th>B</th> <th>C</th> </tr> </thead> <tbody> <tr> <td>$D \leq 0.15\text{mm}$</td> <td>NC</td> <td>B</td> <td>C</td> </tr> <tr> <td>$0.15 < D \leq 0.30\text{mm}$</td> <td>3</td> <td>NC</td> <td>NC</td> </tr> <tr> <td>$0.30 < D \leq 0.50\text{mm}$</td> <td>2</td> <td>5</td> <td>NC</td> </tr> <tr> <td>$0.50 < D \leq 1.0\text{mm}$</td> <td>0</td> <td>3</td> <td>NC</td> </tr> <tr> <td>NC: No count</td> <td></td> <td>1</td> <td>NC</td> </tr> </tbody> </table> <p>D: Mean Diameter of Defect</p> <p>Accept - if air bubble at the seal area does not propagate into effective viewing area</p>	Zone / Dimension	Acceptable No.				A	B	C	$D \leq 0.15\text{mm}$	NC	B	C	$0.15 < D \leq 0.30\text{mm}$	3	NC	NC	$0.30 < D \leq 0.50\text{mm}$	2	5	NC	$0.50 < D \leq 1.0\text{mm}$	0	3	NC	NC: No count		1	NC	<p>Acceptable No.</p> <p>$D = (A + B)/2$</p>
Zone / Dimension	Acceptable No.																														
	A	B	C																												
$D \leq 0.15\text{mm}$	NC	B	C																												
$0.15 < D \leq 0.30\text{mm}$	3	NC	NC																												
$0.30 < D \leq 0.50\text{mm}$	2	5	NC																												
$0.50 < D \leq 1.0\text{mm}$	0	3	NC																												
NC: No count		1	NC																												

13.2.4 FUNCTIONAL DEFECT

Defect Category	Defect Description	Criterion	Drawing Specification																
Missing common	Part of the pattern does not light up	Reject																	
Missing segment	One or few segment does not light up	Reject																	
Common-common short	Common and common connected	Reject																	
Segment-segment short	Segment and segment connected	Reject																	
Common – segment short	Common and segment connected	Reject																	
Wrong viewing angle	Wrong viewing angle	Reject if display viewing angle not conform to customer requirement																	
Metal residue	Extra spot lights up at the border of the segment.	Accept if $\leq 0.20\text{mm}$ (mean diameter)																	
Slow response	Response of the display on one side slower than the other side	Reject if it is visible at 30cm distance																	
Reverse twist/ tilt	Segment are darker or clearer than other area of the same segment	Reject																	
Misalignment	Segment fatter or smaller or extra segment	Reject if $> 10\%$ of designed segment width and visible at 30cm distance																	
Pin Hole	Pin hole / void at light up segment	<table border="1"> <thead> <tr> <th>Zone / Dimension</th> <th colspan="3">Acceptable No.</th> </tr> <tr> <th></th> <th>A</th> <th>B</th> <th>C</th> </tr> </thead> <tbody> <tr> <td>$D \leq 0.10\text{mm}$</td> <td>NC</td> <td>NC</td> <td>NC</td> </tr> <tr> <td>$0.10 < D \leq 0.20\text{mm}$</td> <td>3</td> <td>3</td> <td>NC</td> </tr> </tbody> </table> <p>NC: No count</p> <p>D: Mean Diameter of Defect</p>	Zone / Dimension	Acceptable No.				A	B	C	$D \leq 0.10\text{mm}$	NC	NC	NC	$0.10 < D \leq 0.20\text{mm}$	3	3	NC	<p>$D = (A + B)/2$</p>
Zone / Dimension	Acceptable No.																		
	A	B	C																
$D \leq 0.10\text{mm}$	NC	NC	NC																
$0.10 < D \leq 0.20\text{mm}$	3	3	NC																



Defect Category	Defect Description	Criterion	Drawing Specification
Segment Smearing	Light up segment smear	Reject	
Dim segment	Display shows poor contrast at pre set voltage	Reject	

13.2.5 BLACK SPOT, WHITE SPOT AND FOEREIGN MATERIAL

Defect Category	Defect Description	Criterion	Drawing Specification
Black Spot, White Spot and Foreign Material	Black Spot, White Spot and Foreign Material	Zone / Dimension	Acceptable No.
			A B C
		$D \leq 0.10\text{mm}$	NC NC NC
		$0.10 < D \leq 0.20\text{mm}$	3 3 NC
		$0.20 < D \leq 0.30\text{mm}$	1 2 NC
		$D > 0.30 \text{ mm}$	0 0 NC
		NC: No count D: Mean Diameter of Defect	
			<p>$D = (A + B)/2$</p>

13.2.6 LINE SHAPE AND SCRATCHES

Defect Category	Defect Description	Criterion	Drawing Specification
Line shape and scratches	Line shape and scratches	Zone /Dimension	Acceptable No.
		X Y	A B C
		- <0.01mm	NC NC NC
		< 2 mm < 0.02mm	1 1 NC
		<1 mm < 0.0 2mm	1 2 NC

Note: Total defects shall not exceed five



14. Precaution for using LCM

1. Liquid Crystal Display (LCD)

LCD is made up of glass, organic sealant, organic fluid and polymer based polarizers. The following precautions should be taken when handling.

- b) Keep the temperature within the range of use and storage. Excessive temperature and humidity could cause polarization degradation, polarizer peel off or bubble.
- c) Do not contact the exposed polarizer with anything harder than HB pencil lead. To clean dust off the display surface, wipe gently with cotton, chamois or other soft material soaked in petroleum benzin.
- d) Wipe off saliva or water drops immediately. Contact with water over a long period of time may cause polarizer deformation or colour fading, while an active LCD with water condensation on its surface will cause corrosion of ITO electrodes.
- e) Glass can be easily chipped or cracked from rough handling, especially at corners and edges.
- f) Do not drive LCD with DC voltage.

2. Liquid Crystal Display Modules.

2.1 Mechanical Considerations

LCM are assembled and adjusted with a high degree of precision. Avoid excessive shocks and do not make any alterations or modification. The following should be noted.

- a) Do not tamper in any way with the tabs on the metal frame.
- b) Do not modify the PCB by drilling extra holes, changing its outline, moving its component or modifying its pattern.
- c) Do not touch the elastomer connector, especially insert a backlight panel (for example, EL)
- d) When mounting a LCM make sure that the PCB is not under any stress such as bending or twisting. Elastomer contacts are very delicate and missing pixels could result from slight dislocation of any of the elements.

- a) Avoid pressing on the metal bezel, otherwise the elastomer connector could be deformed and lose contact, resulting in missing pixels.

2.2 Static Electricity

LCM contains CMOS LSI's and the same precaution for such devices should apply, namely

- a) The operator should be grounded whenever he/she comes into contact with the module. Never touch any of the conductive parts such as the LSI pads, the copper leads on the PCB and the interface terminals with any parts of the human body.
- b) The modules should be kept in antistatic bags or other containers to static for storage.
- c) Only properly grounded soldering irons should be used.
- d) If an electric screwdriver is used, it should be well grounded and shielded from commutator spark.
- e) The normal static prevention measures should be observed for work clothes and working benches, the latter conductive (rubber) mat is recommended.
- f) Since dry air is inductive to statics, a relative humidity of 50-60% is recommended.

2.3 Soldering

- a) Solder only to the I/O terminals.
- b) Use only soldering irons with proper grounding and no leakage.
- c) Soldering temperature: 280 °C
- d) Soldering time: 3 to 4 sec
- e) Use eutectic solder with resin flux fill.
- f) If flux is used, the LCD surface should be covered to avoid flux spatters. Flux residue should be removed afterwards.



2.4 Operation

- a) The contrast can be adjusted by varying the LCD driving voltage V_0
- b) Driving voltage should be kept within specified range, excess voltage shortens display life.
- c) Response time increases with decrease in temperature.
- d) Display may turn black or dark blue at temperature above its operational range, this is (however not pressing on the viewing area) may cause the segments to appear “fractured”.
- e) Mechanical disturbance during operation (such as pressing on the viewing area) may cause the segments to appear “fractured”.

2.5 Storage

If any fluid leaks out of the damaged glass cell, wash off any human part that comes into contact with soap and water. Never swallow the fluid. The toxicity is extremely low but caution should be exercised at all the time.

2.6 Limited Warranty

Unless otherwise agreed between Crystal Clear Technology and customer, Crystal Clear Technology will replace or repair any of its LCD and LCM which is found to be defective electrically and visually when inspected in accordance with Crystal Clear Technology acceptance standards, for a period of one year from date of shipment. Confirmation of such date shall be based on freight documents. The warranty liability of Crystal Clear Technology is limited to repair and/or replacement on the terms set forth above. Crystal Clear Technology will not be responsible for any subsequent or consequential events.



Crystal Clear Technology
16 Jalan TP5—Taman Perindustrian Sime UEP
47600 Subang Jaya—Selangor DE
Malaysia