

# CRYSTAL CLEAR TECHNOLOGY

## Product Specification

**T500T02X00**

(REVISION 5)

**Crystal Clear Technology Sdn. Bhd.**

16 Jalan TP5, Taman Perindustrian Sime UEP,

47600 Subang Jaya, Selangor DE

Tel: +603-80247099

Website: [www.cct.com.my](http://www.cct.com.my)

---





2.0 Records of Revision

Rev	Date	Item	Page	Comment	Originator	Checked By
1.0	11-11-15			Initial Release	Azhar	Liew
2.0	28.01.16			Change model name T500B02N00 to T500X02X00	Azhar	Azhar
3.0	10.05.16			Change model name T500X02X00 to T500B02X00, change reliability test condition, change inspection criteria.	Adam	Azhar
4.0	10.10.16	3	3	Add Surface Treatment Change angle (T500B02X00 change to T500T02X00)	Azhar	Azhar
		12	21	Add RTP version		



3.0 General Specification

T500T02X00 is 5.0" color TFT-LCD (Thin Film Transistor Liquid Crystal Display) module composed of LCD panel, driver ICs control circuit, LED backlight. This display area contains 480(RGB) X 272 pixels and can display up to 16.7M colors. This product compliant with RoHS environmental requirement.

Item	Contents	Unit	Note
LCD Type	5.0" TFT	-	
Display color	16.7M		1
Viewing Direction (Optimum View)	12	O 'Clock	
Module size	120.70(W) x 75.80(H) x 3.25 (D)	mm	2
Active Area(W×H)	110.88(W) x 62.832(H)	mm	
Number of Dots	480×RGB×272	dots	
Controller	ILI6480B	-	
Backlight	12 White LEDs	pcs	
Brightness	500	cd/m2	
Surface Treatment	Anti-Glare		
Interface Mode	RGB – 24bit	-	

Note1: Color tone is slightly changed by temperature and driving voltage.

Note2: FPC or wire are not included.

Note3: Brightness on LCD surface. Module with CTP or RTP, brightness will be about 20% (max) lower on the touch panel surface.

AVAILABLE OPTION

X  0  0  X

TOUCH PANEL  
 N : Without Touch Panel  
 C : Capacitive Touch Panel  
 R : Resistive Touch Panel

SEMI - CUSTOMISE (MINOR CHANGES FROM STANDARD MODEL)  
 00 - STANDARD SPECIFICATION MODEL

OTHER OPTION  
 C : STANDARD COVER LENS

REFER TO FACTORY FOR FURTHER INFORMATION.  
 TERMS AND CONDITIONS APPLY



4.0 Absolute Maximum Ratings

Parameter	Symbol	Values		Unit	Remarks
		Min	Max		
Power Voltage	V <sub>DD</sub>	-0.5	5.0	V	
Input Signal Voltage	V <sub>CC</sub>	-0.5	IOV <sub>CC</sub> +0.3	V	
Operation Temperature	T <sub>OP</sub>	-10	60	°C	Note 2,3
Storage Temperature	T <sub>ST</sub>	-20	70	°C	Note 2,3
Humidity	RH	-	90%	%	Note 2

Note1: The absolute maximum rating values of this product are not allowed to be exceeded at any times. A module should be used with any of the absolute maximum ratings exceeded, the characteristics of the module may not be recovered, or in an extreme condition, the module may be permanently destroyed.

Note2: 90% RH max (Max wet temp is 40°C)

Maximum wet-bulb temperature is at 38°C or less and no condensation (no drops of dew)

Note 3: In case of temperature below 0°C, the response time of liquid crystal (LC) becomes slower and the color of panel darker than normal one.

**5.0 Electrical Characteristics and Instruction Code****5.1 Electrical Characteristics (V<sub>ss</sub> = 0V, T<sub>a</sub> = 25°C)**

Parameter	Symbol	Min	Typ	Max	Unit
Power supply	VCC/VCI	3.0	3.3	3.6	V
I/O Power Supply	IOVCC	3.0	3.3	3.6	mA
Input Voltage 'H' level	VIH	0.7IOVCC	-	IOVCC	V
Input Voltage 'L' level	VIL	-0.3	-	0.3IOVCC	V
Output Voltage 'H' level	VOH	0.8IOVCC	-	-	V
Output Voltage 'L' level	VOL	-	-	0.2IOVCC	

**Note:**

- 1: When an optimum contrast is obtained in transmissive mode.
- 2: Tested in 1X1 chessboard pattern.

**5.2 LED Backlight Specification (V<sub>ss</sub> = 0V, T<sub>a</sub> = 25°C)**

Item	Symbol	Condition	Min	Typ	Max	Unit	Note
Supply Voltage	V <sub>LED</sub>	T <sub>a</sub> = 25°C I <sub>f</sub> = 40mA	18.6	19.2	21	V	1
Supply Current	I <sub>f</sub>	-	-	40	-	mA	2
Led lifetime			50000				3

**Note:**

1. V<sub>LED</sub> = V<sub>LED</sub> (+) - V<sub>LED</sub> (-).
2. Using Condition: Constant current driving method I<sub>f</sub> = 40(±10%)mA
3. Definition of Lifetime: Luminance < 50% of initial Luminance  
(Test condition: T<sub>a</sub> = 25°C, Constant current supply (typical Value))

**5.3 Interface Signal**

Pin No.	Symbol	I/O	Function
1	VLED-	I	LED back light(Cathode)
2	VLED+	I	LED back light(Anode)
3	GND		GND
4	VDD	I	Power supply
5-12	R0~R7	I	Red data bus
13-20	G0~G7	I	Green data bus
21-28	B0~B7	I	Blue data bus
29	GND		GND
30	PCLK	I	Data clock
31	DISP	I	Standby mode select pin
32	HSYNC	I	Line SYNC signal
33	VSYNC	I	Frame SYNC signal
34	END(DEN)	I	Data Enable
35	NC	O	No Connection
36	GND		GND
37	XR/NC	O	For Resistive Touch panel only
38	YD/NC	O	
39	XL/NC	O	
40	YU/NC	O	



6.0 Optical Characteristics

Items	Symbol	Condition	Min	Typ	Max	Unit	Remark	
Response Time	Tr + Tf	$\Theta = 0^\circ$ $\emptyset = 0^\circ$ $T_a = 25^\circ\text{C}$	-	30	50	Ms	Fig.1	Note4
Contrast Ratio	Cr		350	500	-	-	Fig.2	Note1
Uniformity	$\Delta$ White		70	80	-	%	Fig2	Note3
Surface Luminance	Lv			500		Cd/m <sup>2</sup>	Fig.2	Note2
Viewing Angles	$\theta_3 = 90$	CR>10	40	55	-	°	Fig.3	Note6
	$\theta_9 = 270$		55	65	-			
	$\theta_{12} = 0$		55	65	-			
	$\theta_6 = 180$		55	65	-			
CIE (x,y) chromaticity	Red	X <sub>R</sub>	0.558	0.608	0.658	-	Fig.2	Note5
		Y <sub>R</sub>	0.255	0.334	0.384	-		
	Green	X <sub>G</sub>	0.255	0.305	0.355	-		
		Y <sub>G</sub>	0.506	0.556	0.606	-		
	Blue	X <sub>B</sub>	0.085	0.135	0.185	-		
		Y <sub>B</sub>	0.087	0.138	0.187	-		
	White	X <sub>w</sub>	0.26	0.31	0.36	-		
		Y <sub>w</sub>	0.26	0.31	0.36	-		

Note1: Contrast Ratio (CR) is defined mathematically by the following formula. For more information see FIG 2:

$$\text{Contrast Ratio} = \frac{\text{Average Surface Luminance with all white pixels (P 1 ~ P9)}}{\text{Average Surface Luminance with all black pixels (P 1 ~ P9)}}$$

Note 2: Surface luminance is the LCD surface from the surface with all pixels displaying white. For more information see FIG 2.

Lv = Average Surface Luminance with all white pixels (P1 ~ P9)

Note 3: The uniformity in surface luminance (WHITE) is determined by measuring luminance at each test position 1 through 9, and then dividing the maximum





luminance of 9 points luminance by minimum luminance of 9 points luminance. For more information see FIG 2.

$$\Delta \text{ WHITE} = \frac{\text{Minimum Surface Luminance with all white pixels (P1 ~ P9)}}{\text{Minimum Surface Luminance with all white pixels (P1 ~ P9)}}$$

Note 4: Response time is the time required for the display to transition from White to black (Rise Time, Tr) and from black to white (Decay Time, Tf). For additional information see FIG 1.

Note 5: CIE (x, y) chromaticity, The x,y value is determined by screen active area position 5. For more information see FIG 2.

Note 6: Viewing angle is the angle at which the contrast ratio is greater than 2. For TFT module the contrast ratio is greater than 10. The angles are determined for the horizontal or x axis and the vertical or y axis with respect to the z axis which is normal to the LCD surface. For more information see FIG 3.

Note 7: For viewing angle and response time testing, the testing data is based on Autronic-Melchers's ConoScope. Series Instruments. For contrast ratio, Surface Luminance, Luminance uniformity and CIE, the testing data is based on TOPCON's BM-5 photo detector.

Note 8: For TFT module, Grey scale reverse occurs in the direction of panel viewing angle

Note 9: Definition of optical measurement system. The optical characteristics should be measured in dark room. After 30 minutes operation, the optical properties are measured at the center point of the LCD screen. (Response time is measured by Photo detector TOPCON BM-7, other items are measured by BM-5A/Field of view: 1° /Height: 500mm.)

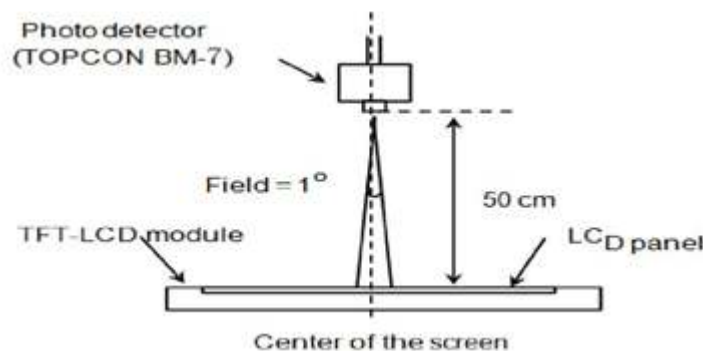



Fig.1: The Definition of Response Time

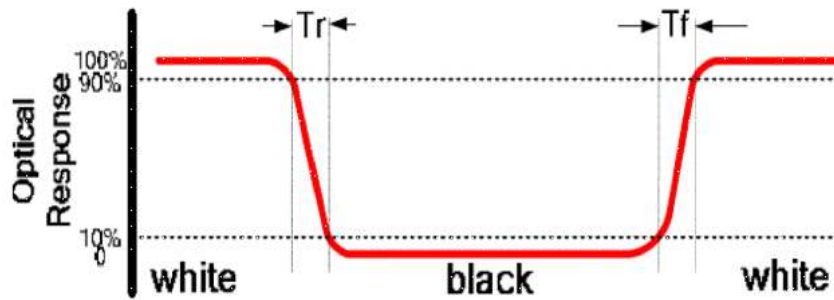

Fig.2: Measuring method for Contrast Ration surface luminance, Luminance uniformity, CIE (x,y) chromaticity

A: 5 mm

B: 5 mm

H, V: Active Area

Light spot size = 5mm,

500 mm distance from the LCD surface to detector lens

Measurement Instrument is TOPCON's luminance meter BM-7

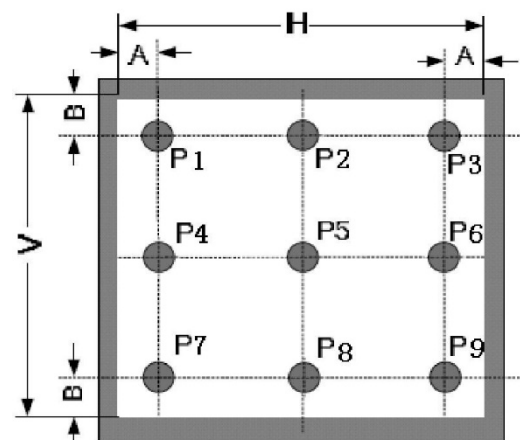
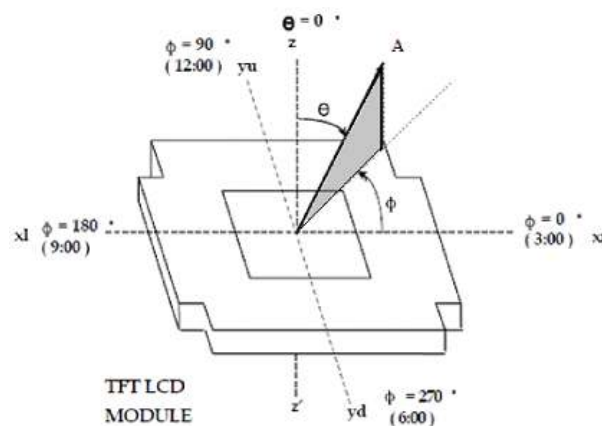

Fig.3: The definition of viewing angle





### 7.0 Power Sequence

To prevent a latch-up or DC operation of the LCD module, the power on/off sequence shall be as shown below:-

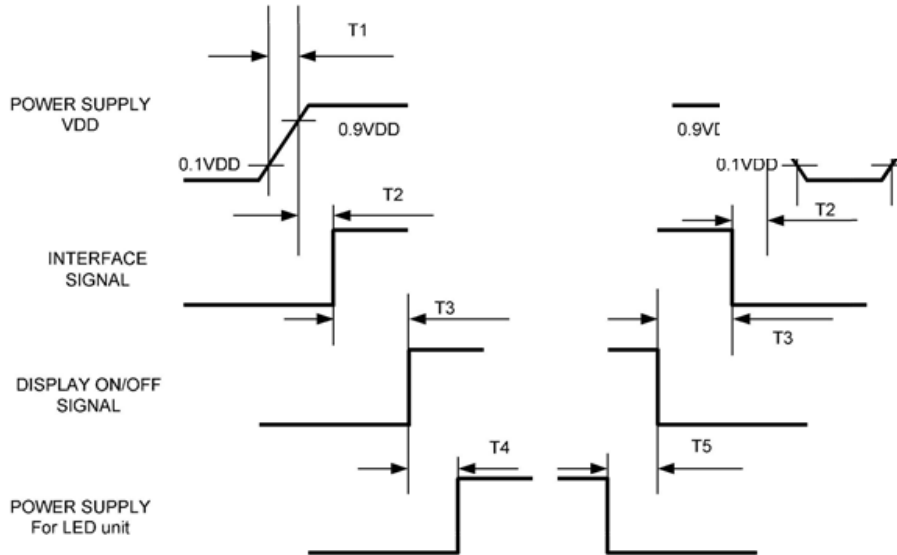

### 8.0 Timing Characteristics

#### 8.1 Timing Conditions

Item	Symbol	Values			Unit	Remark
		Min.	Typ.	Max.		
Horizontal display area	thdisp	480			DCLK	
DCLK frequency	Fclk	5	9	12	MHZ	
1 Horizontal line	th	520	525	800	DCLK	
HSYNC pulse width	thw	1	2	-		
HSYNC Back Porch (blanking)	thbp	36	40	255		
HSYNC front porch	thfp	4	5	65		
Vertical display area	tvdsp	272			H	
VSD period time	tv	275	288	335		
VSD pulse width	tw	1	10	-		
VSD Back Porch (blanking)	tvbp	3	8	31		
VSD front porch	tvfp	4	5	65		

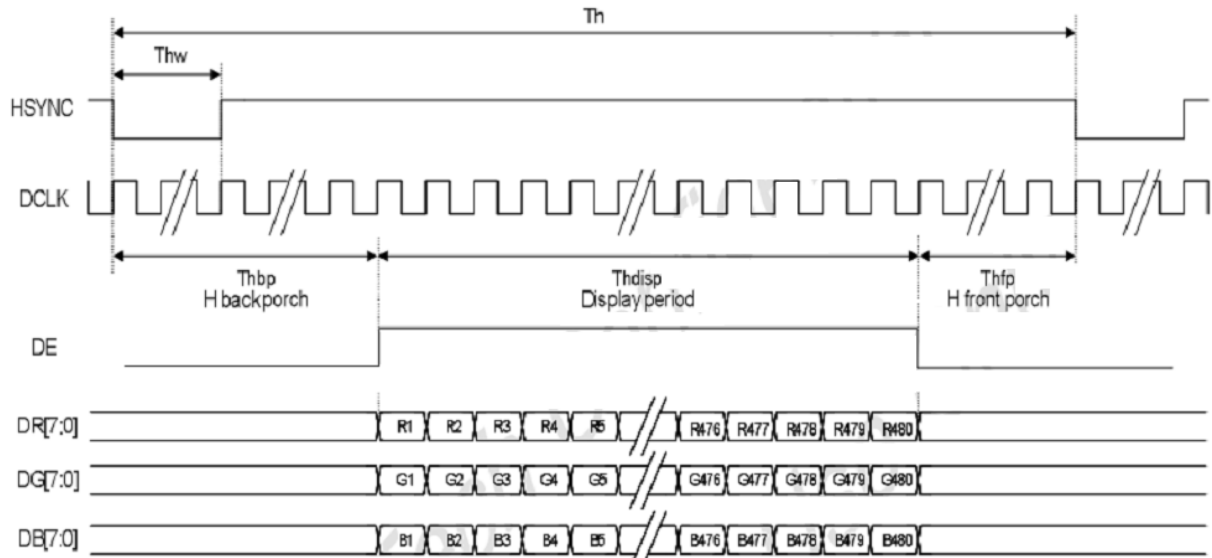

### 8.2 Timing Diagram

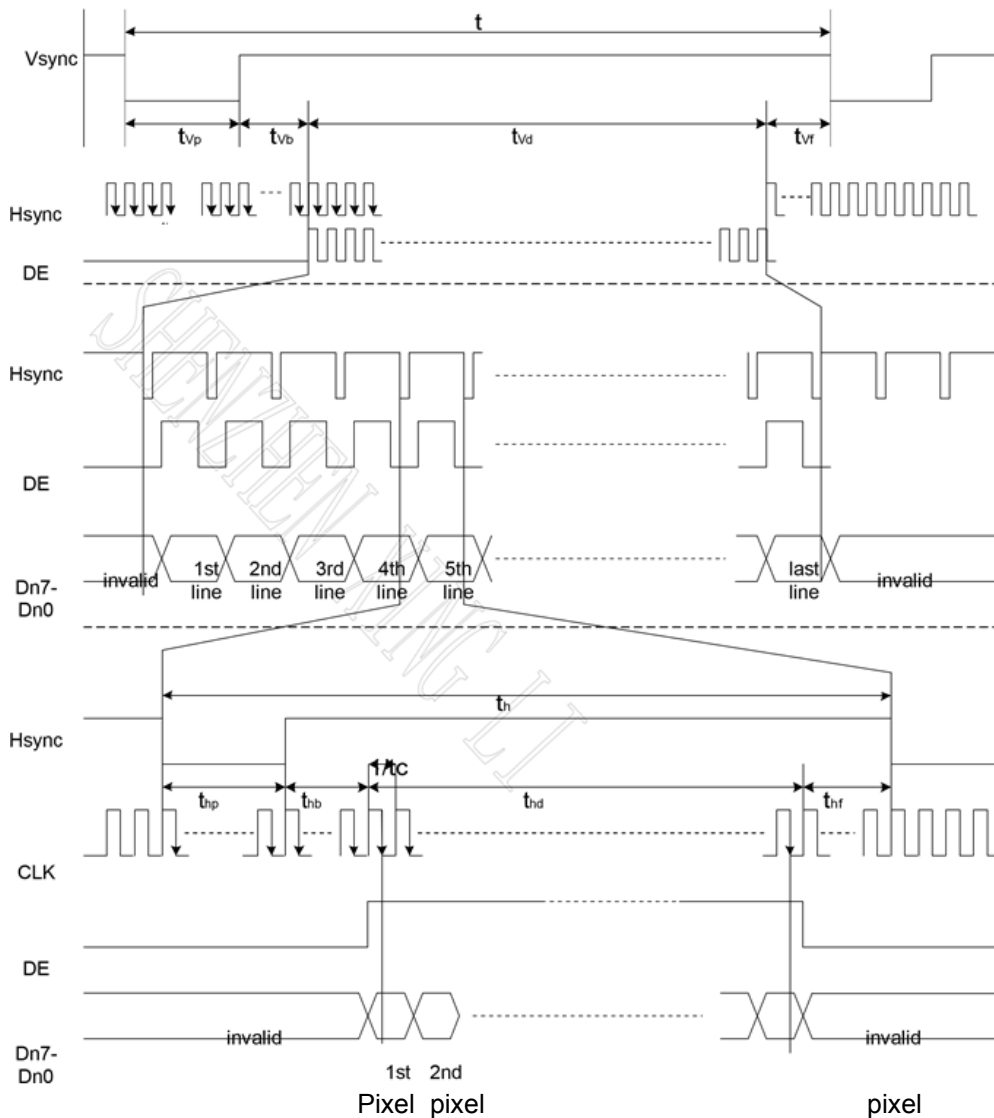

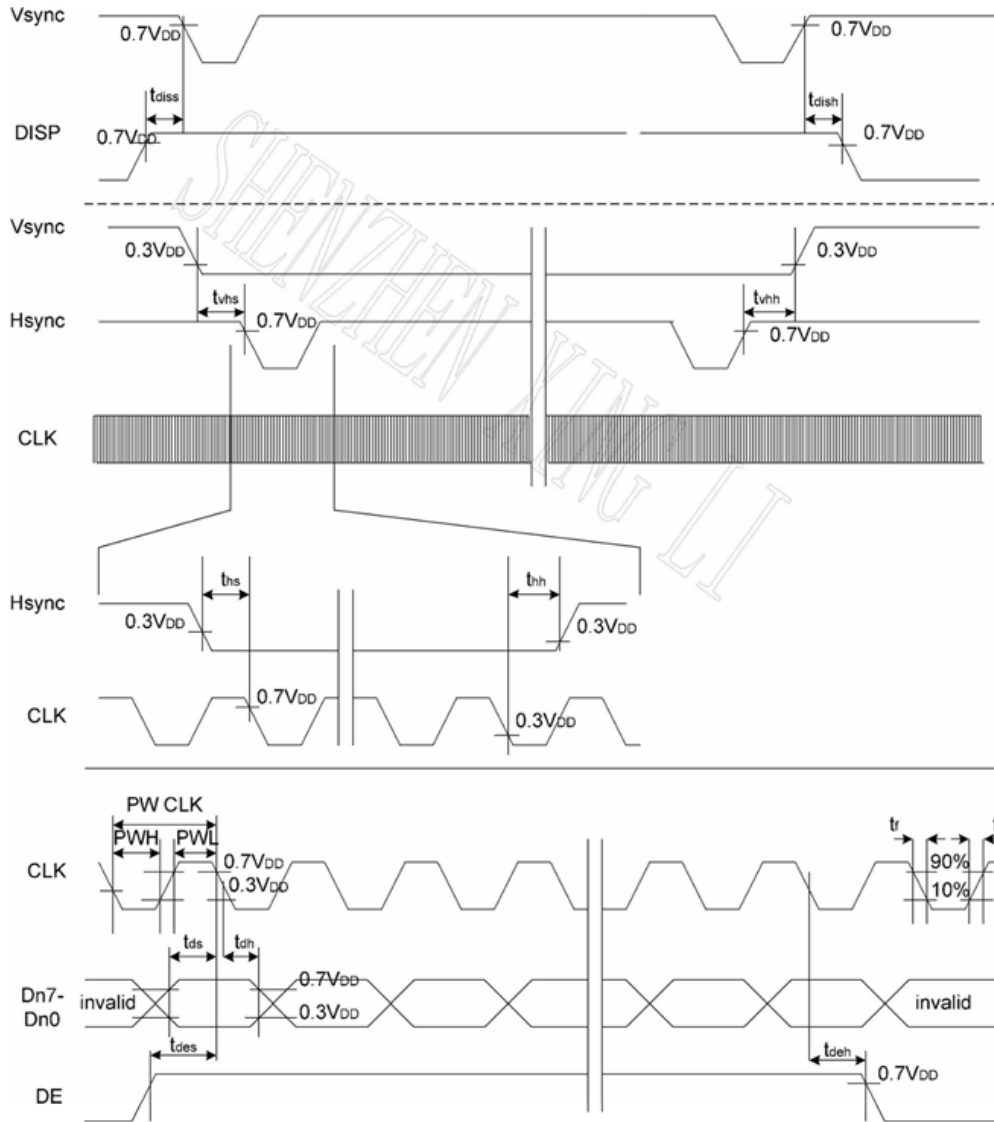



**9.0 Reliability Test Condition**

Item		Test Condition
Operating	High Temperature	60degC, 240 hrs
	Low Temperature	-10degC,240 hrs
Storage	High Temperature	70degC, 240hrs and recovery for 2hrs
	Low Temperature	-20degC, 240hrs and recovery for 2hrs
	High Temperature and High Humidity	50degC, 90%RH, 240hrs and recovery for 2 hrs
Thermal	Cycle	RT → -10degC → Rt → 60degC → RT 0min 30min 5min 30min 5min 50 cycles (Power off)
	Shock	RT → -10degV → 60degC 0min 30min 30min 50 cycles (Power off)

Note: RT means Room temperature



10.0 Inspection Criteria

No	Defect	Definition of defect	Inspection Criteria														
1	a) Definition of dot	<p>The size of defective dot over 1/2 of whole is regards as one defective dot.</p> <p>Smaller than 1/2      Larger than 1/2</p> <p>'No dot defect' (ignore)      '1 dot defect' (counted)</p>	<p>A – Viewing area B – Viewing area C – Outside Viewing area</p>														
	b) Bright Dot	Dot appear bright and unchanged in size when LCD panel is displaying black pattern	<table border="1"> <tr> <th>Defect</th> <th>A</th> <th>B</th> <th>C</th> </tr> <tr> <td>Bright Dot</td> <td>1</td> <td>1</td> <td rowspan="3">NC</td> </tr> <tr> <td>Dark Dot</td> <td>2</td> <td>2</td> </tr> <tr> <td>Total</td> <td colspan="2">4</td> </tr> </table> <p>NC – Not Count</p>	Defect	A	B	C	Bright Dot	1	1	NC	Dark Dot	2	2	Total	4	
	Defect	A	B	C													
	Bright Dot	1	1	NC													
Dark Dot	2	2															
Total	4																
c) Dark Dot	Dot appear dark and unchanged in size when LCD panel is displaying pure color (RED, GREEN or BLUE) pattern	<table border="1"> <tr> <th>Defect</th> <th>A</th> <th>B</th> <th>C</th> </tr> <tr> <td>Bright Dot</td> <td>1</td> <td>1</td> <td rowspan="3">NC</td> </tr> <tr> <td>Dark Dot</td> <td>2</td> <td>2</td> </tr> <tr> <td>Total</td> <td colspan="2">4</td> </tr> </table> <p>NC – Not Count</p>	Defect	A	B	C	Bright Dot	1	1	NC	Dark Dot	2	2	Total	4		
Defect	A	B	C														
Bright Dot	1	1	NC														
Dark Dot	2	2															
Total	4																
d) 2 dot adjacent	<p>1 pair = 2 dots</p> <p>Type 1      Type 2</p> <p>or</p> <p>Type 3</p>	<table border="1"> <tr> <th>Defect</th> <th>Acc. Count</th> </tr> <tr> <td>2 Bright dot Adjacent</td> <td>0</td> </tr> <tr> <td>2 Dark dot Adjacent</td> <td>1</td> </tr> </table>	Defect	Acc. Count	2 Bright dot Adjacent	0	2 Dark dot Adjacent	1									
Defect	Acc. Count																
2 Bright dot Adjacent	0																
2 Dark dot Adjacent	1																
2	<p>Black spot White Spot Bright spot Pin Hole Foreign Particle</p>	<p>-Black/Dark/Bright Spot is points on display which appear dark/bright and usually result from contamination - These defect do not vary in size intensity (contrast) when kontras is varied.</p> <p><math>D=(a+b)/2(mm)</math></p>	<table border="1"> <tr> <th>Defect Category</th> <th>A</th> <th>B</th> </tr> <tr> <td><math>D \leq 0.10</math></td> <td>NC</td> <td rowspan="4">NC</td> </tr> <tr> <td><math>0.10 \leq D \leq 0.20</math></td> <td>2</td> </tr> <tr> <td><math>0.20 \leq D \leq 0.30</math></td> <td>1</td> </tr> <tr> <td><math>D \geq 0.30</math></td> <td>0</td> </tr> </table>	Defect Category	A	B	$D \leq 0.10$	NC	NC	$0.10 \leq D \leq 0.20$	2	$0.20 \leq D \leq 0.30$	1	$D \geq 0.30$	0		
Defect Category	A	B															
$D \leq 0.10$	NC	NC															
$0.10 \leq D \leq 0.20$	2																
$0.20 \leq D \leq 0.30$	1																
$D \geq 0.30$	0																
3	<p>Black Line White line Particle between POL and Glass Scratch on Glass</p>		<table border="1"> <tr> <th>Defect Category</th> <th>A</th> <th>B</th> </tr> <tr> <td><math>W \leq 0.03</math></td> <td>NC</td> <td rowspan="3">NC</td> </tr> <tr> <td><math>0.03 \leq W \leq 0.08, L \leq 2.0</math></td> <td>2</td> </tr> <tr> <td><math>W \geq 0.08</math></td> <td>0</td> </tr> </table>	Defect Category	A	B	$W \leq 0.03$	NC	NC	$0.03 \leq W \leq 0.08, L \leq 2.0$	2	$W \geq 0.08$	0				
Defect Category	A	B															
$W \leq 0.03$	NC	NC															
$0.03 \leq W \leq 0.08, L \leq 2.0$	2																
$W \geq 0.08$	0																
4	<p>POL Bubble POL Dented</p>		<table border="1"> <tr> <th>Defect Category</th> <th>A</th> <th>B</th> </tr> <tr> <td><math>D \leq 0.20</math></td> <td>NC</td> <td rowspan="4">NC</td> </tr> <tr> <td><math>0.20 \leq D \leq 0.30</math></td> <td>3</td> </tr> <tr> <td><math>0.30 \leq D \leq 0.50</math></td> <td>2</td> </tr> <tr> <td><math>D \geq 0.5</math></td> <td>0</td> </tr> </table>	Defect Category	A	B	$D \leq 0.20$	NC	NC	$0.20 \leq D \leq 0.30$	3	$0.30 \leq D \leq 0.50$	2	$D \geq 0.5$	0		
Defect Category	A	B															
$D \leq 0.20$	NC	NC															
$0.20 \leq D \leq 0.30$	3																
$0.30 \leq D \leq 0.50$	2																
$D \geq 0.5$	0																
5	<p>Mura (50% Grey)</p>		<p>Judged by Limit sample</p>														



11.0 Precaution for Using TFT Modules

1. Handling Precautions

- a. The display panel is made of glass and polarizer. As glass is fragile. It tends to chip during handling especially on the edges. Please avoid dropping or jarring. Do not subject it to a mechanical shock of impact or by dropping it.
- b. If the display panel is damaged and the liquid crystal substance leaks out, be sure not to get any in your mouth. If the substance is in contact with your skin or clothes, wash it off using soap and water.
- c. Do not apply excessive force to the display surface or the adjoining areas since this may cause the color tone to vary. Do not touch the display with bare hands. This will stain the display area and degrade the insulation between terminals. Scratch and dents may occur on polarizer too.
- d. The polarizer covering the display surface of the LCD module is soft and easily scratched. Handle this polarizer carefully. Do not touch, push or rub the exposed polarizers with anything harder than a HB pencil lead (glass, tweezers, etc.). Do not put or attach anything on the display area to avoid leaving marks on it. Condensation on the surface and contact with terminals due to cold will damage, stain or dirty the polarizer. After products are tested at low temperature they must be warmed up in a container before coming in to contact with room temperature air.
- e. If the display surface becomes contaminated, breathe on the surface and gently wipe it with a soft dry cloth. If it is heavily contaminated, moisten cloth with one of the following solvents
  - Isopropyl alcohol
  - Ethyl alcohol
  - Do not scrub hard to avoid damaging the display surface.
- f. Solvents other than those above-mentioned may damage the polarizer. Especially, do not use the following.
  - Water
  - Ketone
  - Aromatic solvents
  - Wipe off saliva or water drops immediately, contact with water over a long period of time may cause deformation or color fading. Avoid contact with oil and fats.
- g. Exercise care to minimize corrosion of the electrode. Corrosion of the electrodes is accelerated by water droplets, moisture condensation or a current flow in a high-humidity environment.
- h. Install the LCD Module by using the mounting holes. When mounting the LCD module make sure it is free of twisting, warping and distortion. In particular, do not forcibly pull or bend the I/O cable or the backlight cable.
- i. Do not attempt to disassemble or process the LCD module.
- j. NC terminal should be open. Do not connect anything.
- k. If the logic circuit power is off, do not apply the input signals.
- l. Electro-Static Discharge Control. Since this module uses a CMOS LSI, the same careful attention should be paid to electrostatic discharge as for an ordinary CMOS IC. To prevent destruction of the elements by static electricity, be careful to maintain an optimum work environment.
  - Before removing LCM from its packing case or incorporating it into a set, be sure the module and your body have the same electric potential. Be sure to ground the body when handling the LCD modules.
  - Tools required for assembly, such as soldering irons, must be properly grounded. Make certain the AC power source for the soldering iron does not leak. When using an electric screwdriver to attach LCM, the screw driver





should be of ground potentiality to minimize as much as possible any transmission of electromagnetic waves produced sparks coming from the commutator of the motor.

- To reduce the amount of static electricity generated, do not conduct assembly and other work under dry conditions. To reduce the generation of static electricity be careful that the air in the work environment is not too dry. A relative humidity of 50%-60% is recommended. As far as possible make the electric potential of your work clothes and that of the work bench the ground potential.
  - The LCD module is coated with a film to protect the display surface. Exercise care when peeling off this protective film since static electricity may be generated.
- m. Since LCM has been assembled and adjusted with a high degree of precision, avoid applying excessive shocks to the module or making any alterations or modifications to it.
- Do not alter, modify or change the shape of the tab on the metal frame.
  - Do not make extra holes on the printed circuit board, modify its shape or change the positions of components to be attached.
  - Do not damage or modify the pattern writing on the printed circuit board.
  - Absolutely do not modify the zebra rubber strip (conductive rubber) or heat seal connector.
  - Except for soldering the interface, do not make any alterations or modifications with a soldering iron.
  - Do not drop, bend or twist the LCM.

## 2. Storage Precautions

When storing the LCD modules, the following precaution are necessary.

- a. Store them in a sealed polyethylene bag. If properly sealed, there is no need for the desiccant.
- b. Store them in a dark place. Do not expose to sunlight or fluorescent light, keep the temperature between 0°C and 35°C, and keep the relative humidity between 40%RH and 60%RH.
- c. The polarizer surface should not come in contact with any other objects.

## 3. Others

- a. Liquid crystals solidify under low temperature (below the storage temperature range) leading to defective orientation or the generation of air bubbles (black or white). Air bubbles may also be generated if the module is subject to a low temperature.
- b. If the LCD modules have been operating for a long time showing the same display patterns, the display patterns may remain on the screen as ghost images and a slight contrast irregularity may also appear. A normal operating status can be regained by suspending use for some time. It should be noted that this phenomenon does not adversely affect performance reliability.
- c. To minimize the performance degradation of the LCD modules resulting from destruction caused by static electricity etc. Exercise care to avoid holding the following sections when handling the modules.
  - Exposed area of the printed circuit board.
  - Terminal electrode sections.

## 4. Using LCD Modules

### a. Installing LCD Modules

The hole in the printed circuit board is used to fix LCM as shown in the picture below.

Attend to the following items when installing the LCM.



- b. Cover the surface with a transparent protective plate to protect the polarizer and LC cell.

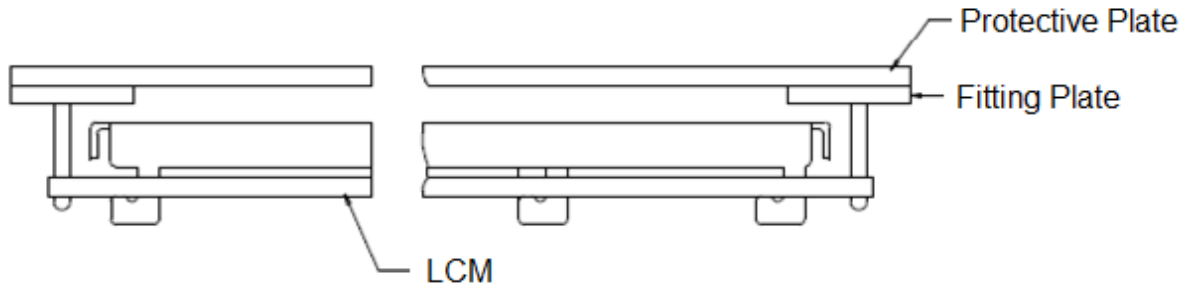

- c. When assembling the LCM into other equipment, the spacer to the bit between the LCM and the fitting plate should have enough height to avoid causing stress to the module surface, refer to the individual specifications for measurements. The measurement tolerance should be 0.1mm.
- d. Precaution for assemble the module with BTB connector:  
Please note the position of the male and female connector position, don't assemble or assemble like the method which the following picture shows



**5. Precaution for soldering the LCM**

	Manual soldering	Machine drag soldering	Machine press soldering
No RoHS Product	290°C ~350°C. Time: 3-5S.	330°C ~350°C. Speed: 4-8 mm/s.	300°C ~330°C. Time: 3-6S. Press: 0.8~1.2Mpa
RoHS Product	340°C ~370°C. Time: 3-5S.	350°C ~370°C. Time: 4-8 mm/s.	330°C ~360°C. Time: 3-6S. Press: 0.8~1.2Mpa

- a. If soldering flux is used, be sure to remove any remaining flux after finishing the soldering operation (This does not apply in the case of a non-halogen type of flux). It is recommended that you protect the LCD surface with a cover during soldering to prevent any damage due to flux spatters.
- b. When soldering the electroluminescent panel and PC board, the panel and board should not be detached more than three times. This maximum number is determined by the temperature and time conditions mentioned above, though there may be some variance depending on the temperature of the soldering iron.
- c. When removing the electroluminescent panel from the PC board, be sure the solder has completely melted, the soldered pad on the PC board could be damaged.

**6. Precautions for Operation**

- a. Viewing angle varies with the change of liquid crystal driving voltage (VLCD).  
Adjust VLCD to show the best contrast.



- b. It is recommended to drive LCD's within the specified voltage limit since over limit will cause shorter LCD life. An electrochemical reaction due to direct current causes LCD-deterioration. Avoid the use of direct current drive.
- c. Response time will be extremely delayed at lower temperature compared to room operating temperature range and on the other hand, at higher temperature LCD shows dark color in them. However those phenomena do not mean malfunction. The LCD will return to normal performance when ambient temperature revert to room condition.
- d. If the display area is pushed hard during operation, the display will become abnormal. However, it will return to normal if it is turned off and on.
- e. A slight dew depositing on terminals is a cause for electro-chemical reaction resulting in terminal open circuit.
- f. Input logic voltage before apply analogue high voltage such as LCD driving voltage when power on. Remove analogue high voltage before logic voltage when power off the module. Input each signal after the positive/negative voltage becomes stable.
- g. Please keep the temperature within the specified range for use and storage. Polarization degradation, bubble generation or polarizer peel-off may occur with high temperature and high humidity.

**7. Safety**

- a. It is recommended to crush damaged or unnecessary LCDs into pieces and wash them off with solvents such as acetone and ethanol, which should later be burned.
- b. If any liquid leaks out of a damaged glass cell and comes in contact with the hands, wash off thoroughly with soap and water.

**8. Limited Warranty**

Unless otherwise agreed between Crystal Clear Technology and customer, Crystal Clear Technology will replace or repair any of its LCD and LCM which is found to be defective electrically and visually when inspected in accordance with Crystal Clear Technology acceptance standards, for a period of one year from date of shipment. Confirmation of such date shall be based on freight documents. The warranty liability of Crystal Clear Technology is limited to repair and/or replacement on the terms set forth above. Crystal Clear Technology will not responsible for any subsequent or consequential events.

**9. Return LCM under Warranty**

No warranty can be granted if the precautions stated above have been disregarded. The typical examples of violations are:

- Broken LCD glass
- PCB eyelet's damaged or modified
- PCB conductors damaged
- Circuit modified in any way, including addition of components.
- PCB tampered with by grinding, engraving or painting varnish.
- Soldering to, or modifying the bezel in any manner.

Module repairs will be invoiced to customer upon mutual agreement. Modules must be returned with sufficient description of failure or defects. Any connectors or cable installed by customer must be removed completely without damaging the PCB eyelet's, conductors and terminals.

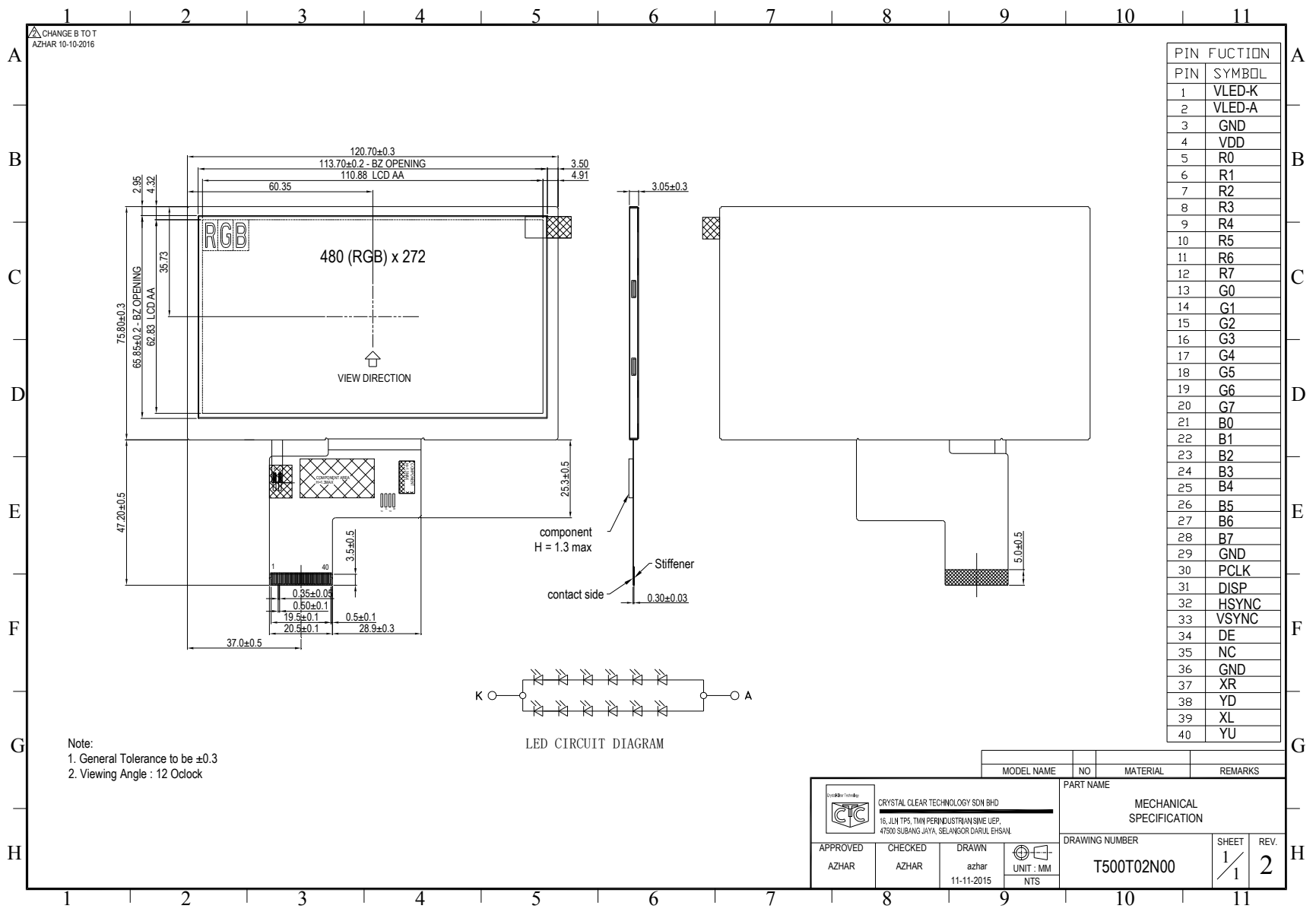

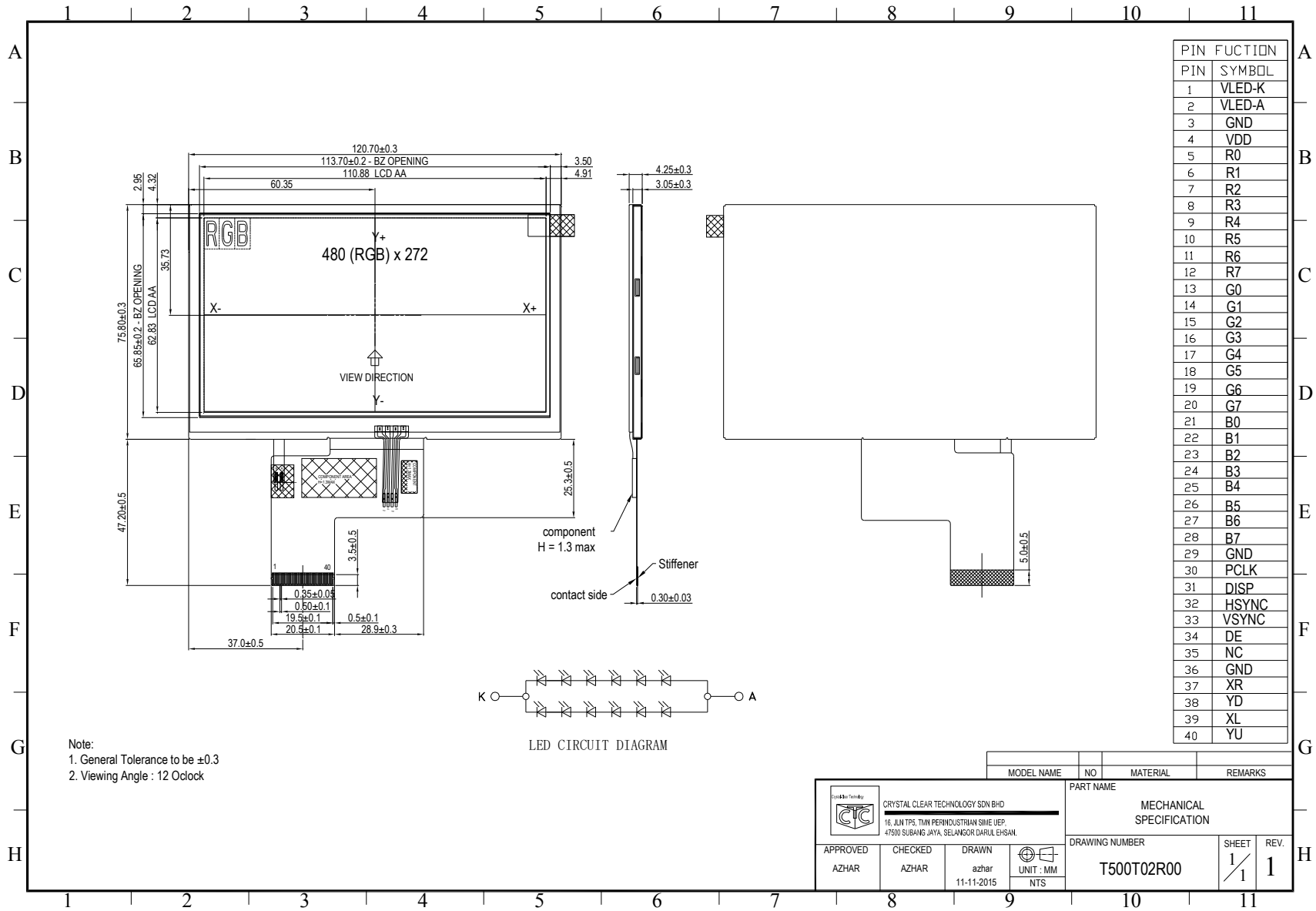

PIN	FUNCTION
1	VLED-K
2	VLED-A
3	GND
4	VDD
5	R0
6	R1
7	R2
8	R3
9	R4
10	R5
11	R6
12	R7
13	G0
14	G1
15	G2
16	G3
17	G4
18	G5
19	G6
20	G7
21	B0
22	B1
23	B2
24	B3
25	B4
26	B5
27	B6
28	B7
29	GND
30	PCLK
31	DISP
32	HSYNC
33	VSYNC
34	DE
35	NC
36	GND
37	XR
38	YD
39	XL
40	YU

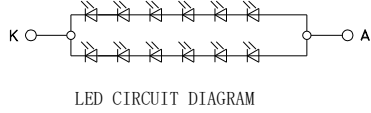

Note:  
 1. General Tolerance to be ±0.3  
 2. Viewing Angle : 12 Oclock

MODEL NAME		NO	MATERIAL	REMARKS																									
<table border="1"> <tr> <td colspan="2"> </td> <td colspan="3">           CRYSTAL CLEAR TECHNOLOGY SDN BHD            15, JLN TFS, TANI PERINDUSTRIAN SIME UEP,            47500 SUBANG JAYA, SELANGOR DARUL EHSAN.         </td> </tr> <tr> <td>APPROVED</td> <td>CHECKED</td> <td>DRAWN</td> <td colspan="2">           PART NAME  <b>MECHANICAL SPECIFICATION</b> </td> </tr> <tr> <td>AZHAR</td> <td>AZHAR</td> <td>azhar 11-11-2015</td> <td>DRAWING NUMBER</td> <td>SHEET</td> </tr> <tr> <td></td> <td></td> <td>UNIT : MM NTS</td> <td>T500T02R00</td> <td>1 / 1</td> </tr> <tr> <td></td> <td></td> <td></td> <td></td> <td>REV. 1</td> </tr> </table>							CRYSTAL CLEAR TECHNOLOGY SDN BHD 15, JLN TFS, TANI PERINDUSTRIAN SIME UEP, 47500 SUBANG JAYA, SELANGOR DARUL EHSAN.			APPROVED	CHECKED	DRAWN	PART NAME <b>MECHANICAL SPECIFICATION</b>		AZHAR	AZHAR	azhar 11-11-2015	DRAWING NUMBER	SHEET			UNIT : MM NTS	T500T02R00	1 / 1					REV. 1
		CRYSTAL CLEAR TECHNOLOGY SDN BHD 15, JLN TFS, TANI PERINDUSTRIAN SIME UEP, 47500 SUBANG JAYA, SELANGOR DARUL EHSAN.																											
APPROVED	CHECKED	DRAWN	PART NAME <b>MECHANICAL SPECIFICATION</b>																										
AZHAR	AZHAR	azhar 11-11-2015	DRAWING NUMBER	SHEET																									
		UNIT : MM NTS	T500T02R00	1 / 1																									
				REV. 1																									

