

# **CRYSTAL CLEAR TECHNOLOGY**

## **Product Specification**

**T700A04X00**

(REVISION 6)

**Crystal Clear Technology Sdn. Bhd.**

16 Jalan TP5, Taman Perindustrian Sime UEP,

47600 Subang Jaya, Selangor DE

Tel: +603-80247099

Website: [www.cct.com.my](http://www.cct.com.my)

---



1.0 Table of Contents

No	Title	Page
1	Table of Contents	1
2	Record of revision	2
3	General Specification	3
4	Absolute Maximum Ratings	4
5	Electrical Characteristics and Instruction Code	5
6	Optical Characteristics	9
7	Signal Timing Specification	13
8	Power Sequence	16
9	RA Test Condition	17
10	Inspection Criteria	18
11	Precaution and Limited Warranty	19
12	Mechanical Specification	23
13	Attachment:-	
	1. Capacitive touch panel	



2.0 Records of Revision

Rev	Date	Item	Page	Comment	Originator	Checked By
1.0	25.11.15			Initial Release	Azhar Adam	Liew Azhar
2.0	21.12.16			Revise drawing	Azhar	Azhar
3.0	21.04.17			Revise drawing T700A04C00C - CTP pin out		
4.0	17/11/17	3 5	3 5	Add Pixel Pitch Revise Electrical Characteristics	Azhar	Azhar
5.0	05/12/17	12	24	Update Mechanical Specification	Azhar	Azhar
6.0	07/01/19	12	24	Update Mechanical Specification	Azhar	Azhar



### 3.0 General Specification

T700A04X00 is a color active matrix TFT LCD module using amorphous silicon TFT's (Thin Film Transistors) as an active switching devices. This module has a 7.0inch diagonally measured active area with WSVGA resolutions (1024 horizontal by 600 vertical pixel array). Each pixel is divided into RED, GREEN, BLUE dots which are arranged in vertical stripe and this module can display 16.7M colors. The TFT-LCD panel used for this module is adapted for a low reflection and higher color type.

Item	Contents	Unit	Note
LCD Type	7.0" TFT	-	
Display color	16.7M	-	1
Viewing Direction (Optimum View)	All angle	-	
Operating temperature	-20~+65	°C	
Storage temperature	-30~+80	°C	
Module size	164.05 x 100.86 x 2.35	mm	2
Active Area (W×H)	153.6 x 90.0	mm	
Number of Dots	1024(RGB) × 600	dots	
Pixel Pitch	0.15 x 0.15	mm	
Controller	-	-	
Backlight	20 White LEDs	pcs	
Brightness	400 (typ)	cd/m2	
Interface Mode	LVDS	-	
Technology Type	a-Si		
Surface Treatment	3H HC + LR	-	

Note 1: Color tone is slightly changed by temperature and driving voltage.

Note 2: FPC or wire are not included.



### 4.0 Absolute Maximum Ratings

#### 4.1 Electrical Absolute Maximum ratings (Vss = 0V, Ta = 25°C)

Item	Symbol	Min.	Max.	Unit	Note
Power Supply Voltage	VDD	-0.3	4.2	V	1, 2
Power Supply for LED	VLED	-0.3	40	V	

Notes:

1. If the module is above these absolute maximum ratings. It may become permanently damaged.
2. VDD >VSS must be maintained.
3. Please be sure users are grounded when handing LCD Module.

#### 4.2 Environmental Absolute Maximum Ratings

Item	Storage		Operating		Note
	MIN.	MAX.	MIN.	MAX.	
Ambient Temperature	-30°C	80°C	-20°C	65°C	1,2
Humidity	-	-	-	-	3

1. The response time will become lower when operated at low temperature.
2. Background color changes slightly depending on ambient temperature. The phenomenon is reversible.
3. Ta ≤ 40°C and 85%RH MAX.  
(Ta > 40°C. Absolute humidity must be lower than the humidity of 85%RH at 40°C)

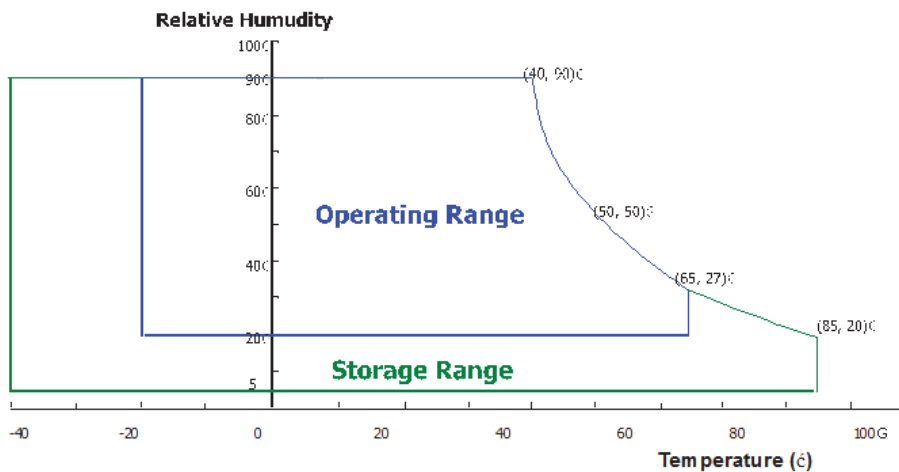

**5.0 Electrical Characteristics and Instruction Code****5.1 Electrical Characteristics (V<sub>SS</sub> = 0V, T<sub>a</sub> = 25°C)**

Parameter	Symbol	Values			Unit	Condition
		Min	Typ	Max		
Power Supply Input Voltage*1	V <sub>DD</sub>	3.2	3.7	4.2	V	
Power Supply Current*1	I <sub>DD</sub>	-	550	-	mA	V <sub>DD</sub> = 3.7V
		-	650	-	mA	V <sub>DD</sub> = 3.3V
LED Driver Efficiency*2		-	84	-	%	
Positive-going Input Threshold Voltage	V <sub>IT+</sub>	-	-	+100	mV	V <sub>COM</sub> = 1.2V (typ)
Negative-going Input Threshold Voltage	V <sub>IT-</sub>	-100	-	-	mV	
Differential input Common mode Voltage	V <sub>com</sub>	-	1.2	-	V	V <sub>IH</sub> = 100mV V <sub>IL</sub> = -100mV
Power Consumption	P <sub>D</sub>	-	0.56	0.65	W	White Pattern
	P <sub>BL</sub>	-	1.50	1.55	W	
	P <sub>TOTAL</sub>	-	2.06	2.2	W	

(\*) Notes:

1. The supply voltage is measured and specified at the interface connector of LCM. The current draw and power consumption specified is for 3.7V at 25°C
2. Calculated value for reference (V<sub>LED</sub> X I<sub>LED</sub>)
3. CTF of Power Supply Current: P<sub>D</sub> /P<sub>BL</sub>



5.2 Recommended Driving Condition for Backlight

ITEM	Symbol	Min	Typ	Max	Unit	Note
Current for each LED	I <sub>LED</sub>	-		20	mA	
Voltage for each LED	V <sub>LED</sub>		3	3.3	V	
Input Current	I <sub>B</sub>	-		80	mA	Total 20 LEDs, 4 Strings, 5 EA each string
Input Voltage	V <sub>B</sub>		15	16.5	V	
Power Consumption for Backlight	P <sub>B</sub>		1.50	1.55	W	

With LED driver on customer system, we only have one connector on FPC

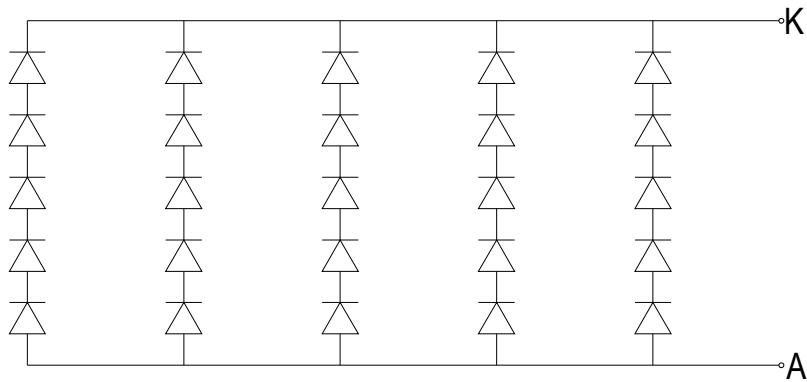



5.3 Interface Connection

The electronics interface recommended connector is PF030-B31B-N09

5.3.1 The connector pin assignment are listed below:-

No.	Symbol	Description
1	VDDIN	Power Supply VDDIN = 3.7V (typ)
2	VDDIN	
3	VDDIN	
4	VDDIN	
5	VDDIN	
6	VDDIN	
7	VDDIN	
8	NC	No connection
9	NC	No connection
10	NC	No connection
11	GND	Ground
12	GND	Ground
13	RIN0-	-LVDS differential data input
14	RIN0+	+LVDS differential data input
15	GND	Ground
16	RIN1-	-LVDS differential data input
17	RIN1+	+LVDS differential data input
18	GND	Ground
19	RIN2-	-LVDS differential data input
20	RIN2+	+LVDS differential data input
21	GND	Ground
22	LVDS_CLK-	-LVDS differential clock input
23	LVDS_CLK+	+LVDS differential clock input
24	GND	Ground
25	RIN3-	-LVDS differential clock input
26	RIN3+	+LVDS differential clock input
27	GND	Ground
28	LED_EN	LED Enable
29	GND	Ground
30	DVDDT	Only for SEC test. Other customers NC
31	GND	Ground





5.3.2 LVDS Interface

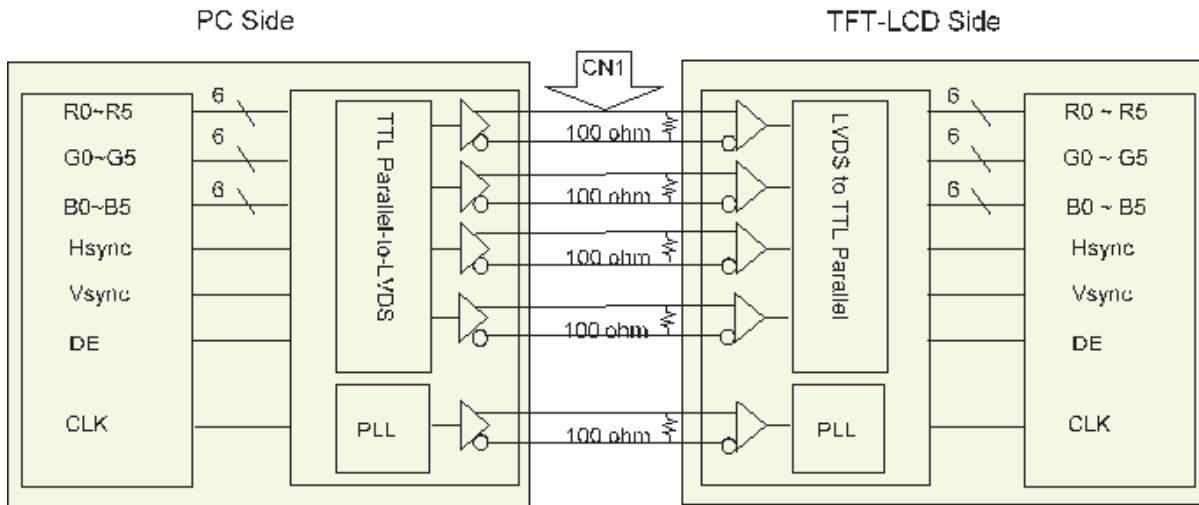

5.3.3 LVDS Input Signal

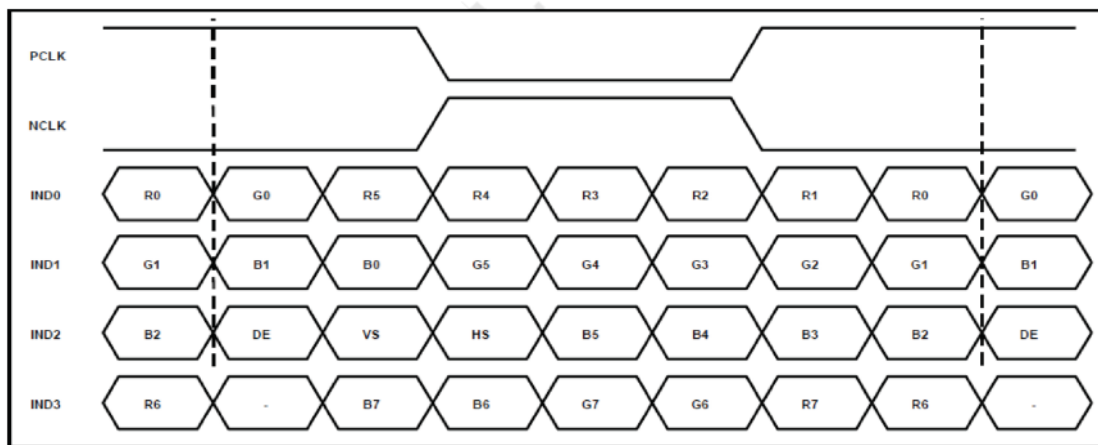

5.3.4 Data Input Format

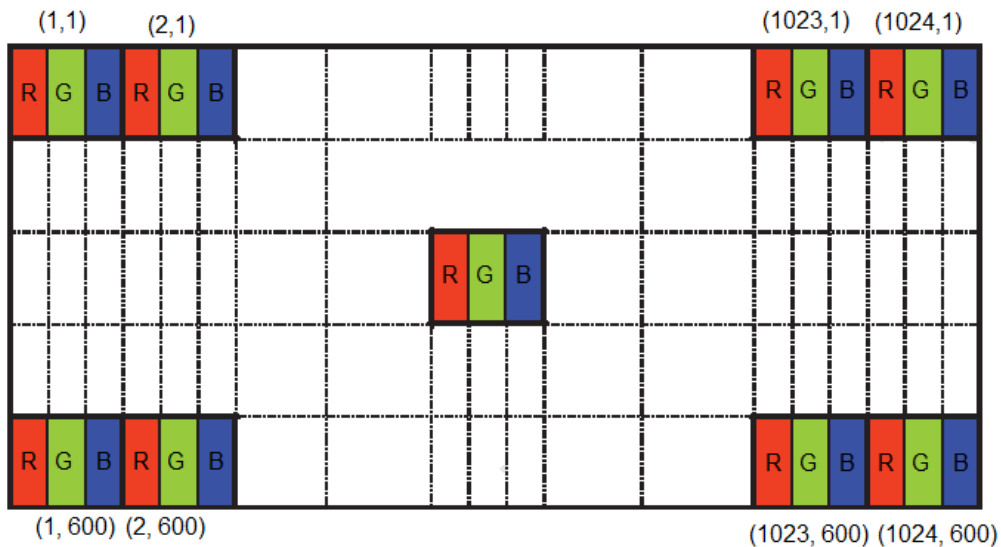

Display Position of Input Data (V-H)



6.0 Optical Characteristics

Items	Symbol	Condition	Min	Typ		Unit	Remark
Response Time	Tr + Tf	$\Theta = 0^\circ$ $\emptyset = 0^\circ$ Ta = 25°C	-	30	-	ms	Note5
Contrast Ratio	Cr		700	900	-	-	Note4
Uniformity	$\Delta$ White		70	-	-	%	Note2
Surface Luminance	Lv		340	400	-	cd/m2	Note1
Viewing Angle	$\theta_3 = 90$	CR>10	-	80	-	°	Note3
	$\theta_9 = 270$		-	80	-		
	$\theta_{12} = 0$		-	80	-		
	$\theta_6 = 180$		-	80	-		
CIE (X, Y) Chromaticity	White	$X_W$	-0.02	0.303	+0.02	-	Note6
		$Y_W$		0.333		-	
	Red	$X_R$		0.600		-	
		$Y_R$		0.340		-	
	Green	$X_G$		0.345		-	
		$Y_G$		0.565		-	
	Blue	$X_B$		0.145		-	
		$Y_B$		0.125		-	
Gamma Scale			2.0	2.2	2.4		

Note: The parameter is slightly changed by temperature, driving voltage and materiel



Note 1: The data are measured after LEDs are turned on for 5 minutes. LCM displays full white. The brightness is the average value of 9 measured spots. Measurement equipment PR-705 (Φ8mm)

Measuring condition:

- Measuring surroundings: Dark room.
- Measuring temperature: Ta=25°C.
- Adjust operating voltage to get optimum contrast at the center of the display.

Measured value at the center point of LCD panel after more than 5 minutes while backlight turning on.

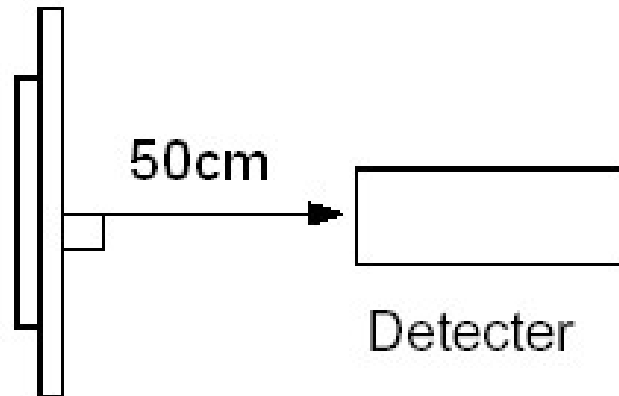

Note 2: The luminance uniformity is calculated by using following formula.

$$\Delta Bp = Bp (\text{Min.}) / Bp (\text{Max.}) \times 100 (\%)$$

Bp (Max.) = Maximum brightness in 9 measured spots  
Bp (Min.) = Minimum brightness in 9 measured spots.

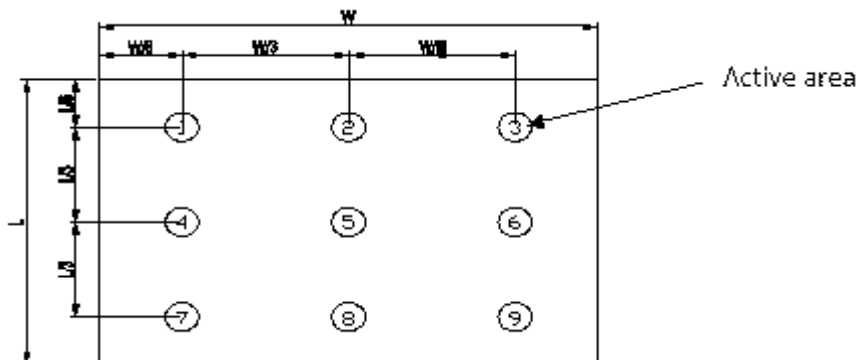

Note 3: The definition of viewing angle:

Refer to the graph below marked by  $\theta$  and  $\Phi$

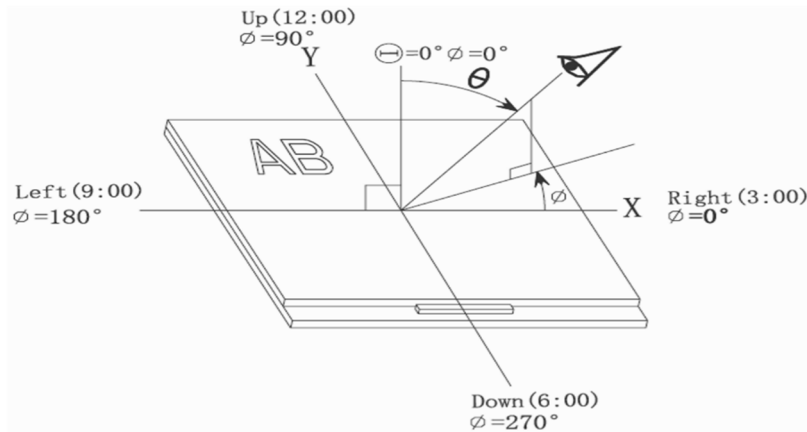

Note 4: Definition of contrast ratio. (Test LCD using DMS501)

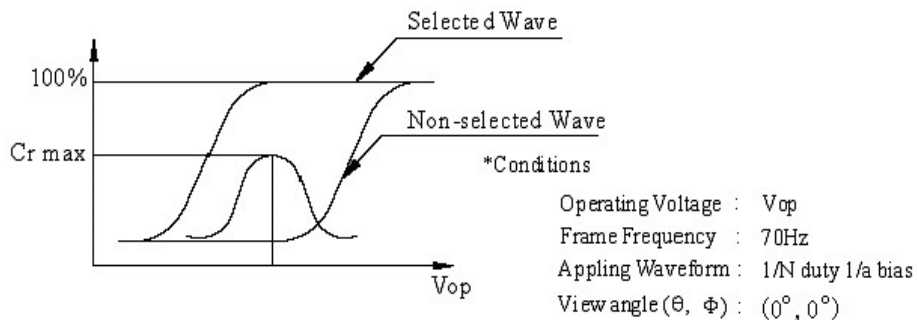

$$\text{Contrast ratio (Cr)} = \frac{\text{Brightness of selected dots}}{\text{Brightness of non-selected dots}}$$

Note 5: Definition of Response time. (Test LCD using DMS501):

The output signals of photo detector are measured when the input signals are changed from “black” to “white” (falling time) and from “white” to “black”(rising time), respectively. The response time is defined as the time interval between the 10% and 90% of amplitudes. Refer to figure as below.

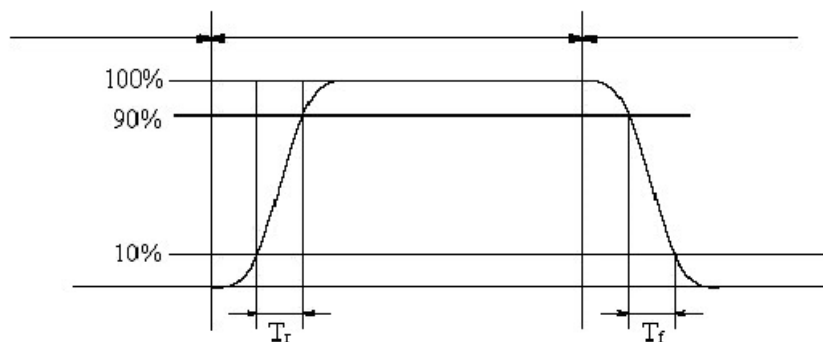

The Definition of response time



Note 6: Definition of Color of CIE Coordinate and NTSC Ratio.

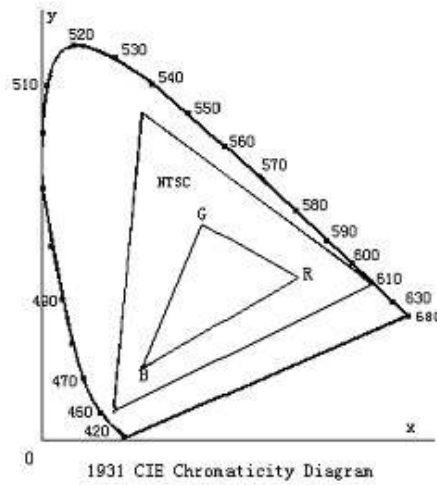

Note 7: Definition of cross talk.

$$\text{Cross talk ratio (\%)} = \frac{[\text{pattern A Brightness} - \text{pattern B Brightness}]}{\text{pattern A}}$$

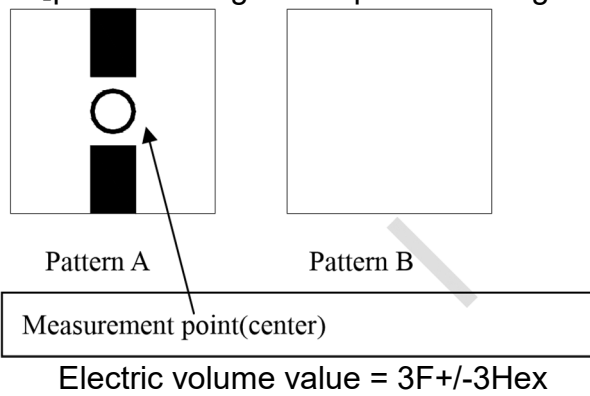

**7.0 Signal Timing Specification****7.1 Operated by DE only**

Item		Symbols	Min	Typ	Max	Unit
Clock	Frequency	1/Tc	40.8	51.2	67.2	MHz
	High Time	Tch	40%	50%	60%	Tc
	Low Time	Tcl	60%	50%	40%	Tc
Frame Period		Tv	610	635	800	Lines
			60	60	60	Hz
			16.6	16.6	16.6	Ms
Vertical Display Period		Tvd	600	600	600	Lines
One Line Scanning Period		Th	1114	1344	1400	clocks
Horizontal Display Period		Thd	1024	1024	1024	clocks

**7.2 LVDS Rx Interface Timing Parameter**

The specification of the LVDS Rx interface timing parameter is shown in table below

Item	Symbol	Min	Typ	Max	Unit	Remarks
CLKIN Period	tRCIP	14.88	19.53	24.51	nsec	
Input Data 0	tRIP1	-0.4	0.0	+0.4	nsec	
Input Data 1	tRIP0	tRICP/7-0.4	tRICP/7	tRICP/7+0.4	nsec	
Input Data 2	tRIP7	2 X tRICP/7-0.4	2 X tRICP/7	2 X tRICP/7+0.4	nsec	
Input Data 3	tRIP6	3 X tRICP/7-0.4	3 X tRICP/7	3 X tRICP/7+0.4	nsec	
Input Data 4	tRIP5	4 X tRICP/7-0.4	4 X tRICP/7	4 X tRICP/7+0.4	nsec	
Input Data 5	tRIP4	5 X tRICP/7-0.4	5 X tRICP/7	5 X tRICP/7+0.4	nsec	
Input Data 6	tRIP3	6 X tRICP/7-0.4	6 X tRICP/7	6 X tRICP/7+0.4	nsec	
Input Data 7	tRIP2	7 X tRICP/7-0.4	7 X tRICP/7	7 X tRICP/7+0.4	nsec	

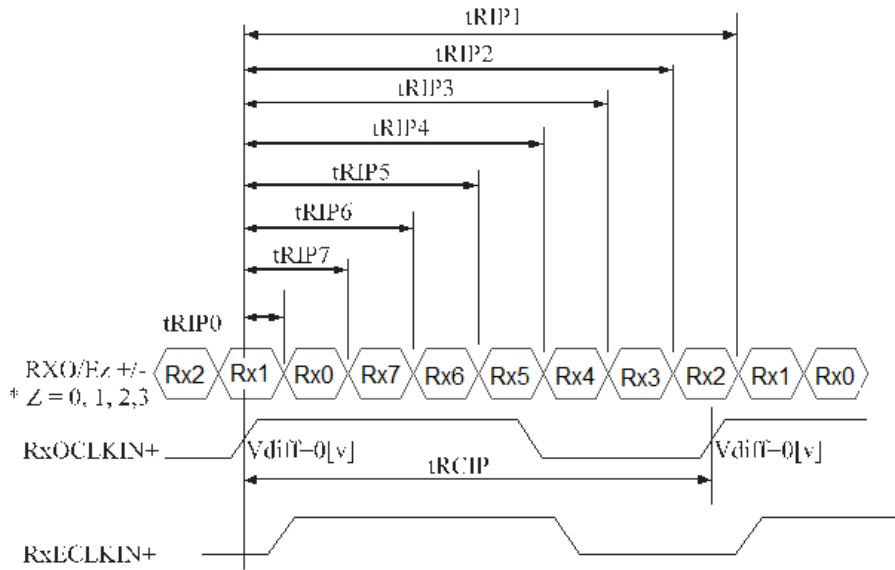

\*  $V_{diff} = (RXO/Ez+) - (RXO/Ez-), f., (RXO/ECLK+) - (RXO/ECLK-)$

### 7.3 Signal Timing Waveforms of Interface Signal

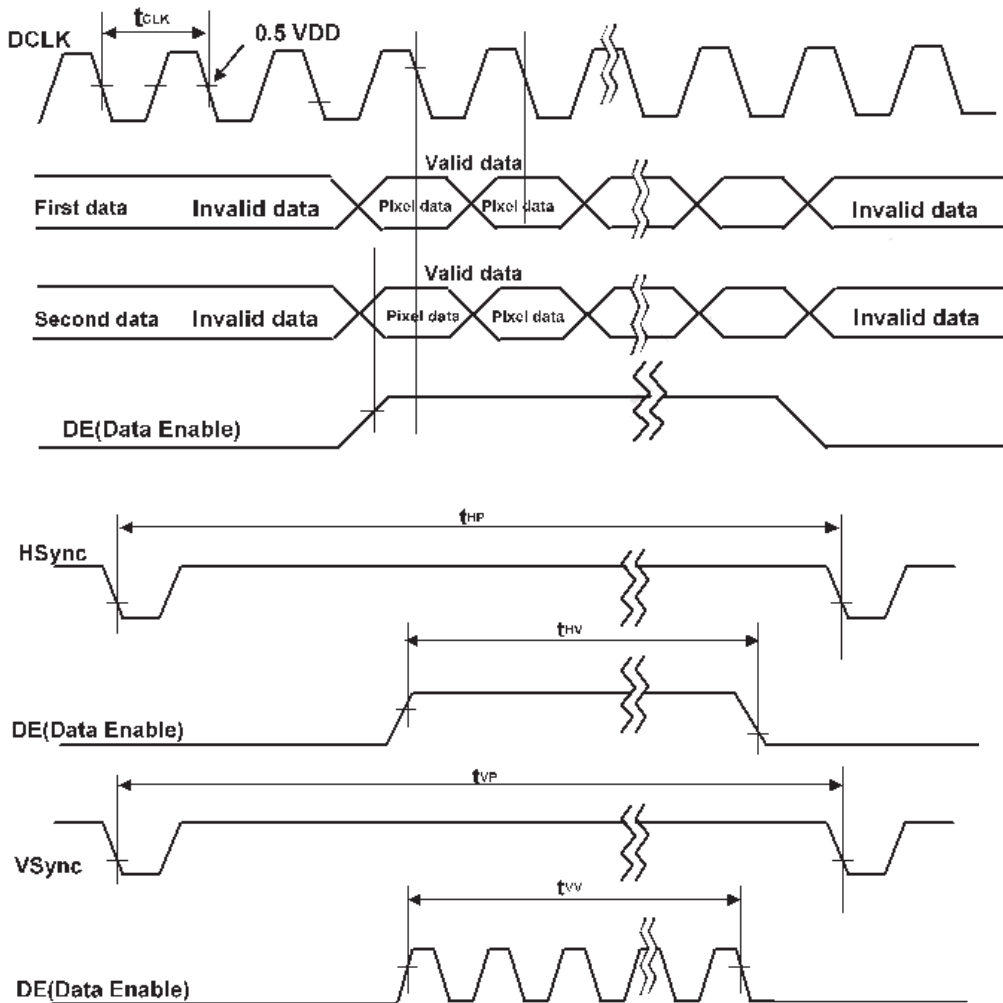



7.4 Input signals, basic display colors and grey scale of colors

Color & Gray Scale		Input Data Signal																							
		Red Data								Green Data								Blue Data							
		R7	R6	R5	R4	R3	R2	R1	R0	G7	G6	G5	G4	G3	G2	G1	G0	B7	B6	B5	B4	B3	B2	B1	B0
Basic Colors	Black	0	0	0	0	0	0	0	0	0	0	0	0	0	0	0	0	0	0	0	0	0	0	0	
	Blue	0	0	0	0	0	0	0	0	0	0	0	0	0	0	0	0	1	1	1	1	1	1	1	
	Green	0	0	0	0	0	0	0	0	1	1	1	1	1	1	1	1	0	0	0	0	0	0	0	
	Cyan	0	0	0	0	0	0	0	0	1	1	1	1	1	1	1	1	1	1	1	1	1	1	1	
	Red	1	1	1	1	1	1	1	1	0	0	0	0	0	0	0	0	0	0	0	0	0	0	0	
	Magenta	1	1	1	1	1	1	1	1	0	0	0	0	0	0	0	0	0	1	1	1	1	1	1	
	Yellow	1	1	1	1	1	1	1	1	1	1	1	1	1	1	1	1	0	0	0	0	0	0	0	
	White	1	1	1	1	1	1	1	1	1	1	1	1	1	1	1	1	1	1	1	1	1	1	1	
Gray Scale of Red	Black	0	0	0	0	0	0	0	0	0	0	0	0	0	0	0	0	0	0	0	0	0	0		
	△	0	0	0	0	0	0	0	1	0	0	0	0	0	0	0	0	0	0	0	0	0	0		
	Darker	0	0	0	0	0	0	1	0	0	0	0	0	0	0	0	0	0	0	0	0	0	0		
	△	↑								↑								↑							
	▽	↓								↓								↓							
	Brighter	1	1	1	1	1	1	0	1	0	0	0	0	0	0	0	0	0	0	0	0	0	0	0	
	▽	1	1	1	1	1	1	1	0	0	0	0	0	0	0	0	0	0	0	0	0	0	0	0	
	Red	1	1	1	1	1	1	1	1	0	0	0	0	0	0	0	0	0	0	0	0	0	0	0	
Gray Scale of Green	Black	0	0	0	0	0	0	0	0	0	0	0	0	0	0	0	0	0	0	0	0	0	0		
	△	0	0	0	0	0	0	0	0	0	0	0	0	0	0	0	1	0	0	0	0	0	0		
	Darker	0	0	0	0	0	0	0	0	0	0	0	0	0	0	1	0	0	0	0	0	0	0		
	△	↑								↑								↑							
	▽	↓								↓								↓							
	Brighter	0	0	0	0	0	0	0	0	1	1	1	1	1	1	0	1	0	0	0	0	0	0		
	▽	0	0	0	0	0	0	0	0	1	1	1	1	1	1	1	0	0	0	0	0	0	0		
	Green	0	0	0	0	0	0	0	0	1	1	1	1	1	1	1	1	0	0	0	0	0	0	0	
Gray Scale of Blue	Black	0	0	0	0	0	0	0	0	0	0	0	0	0	0	0	0	0	0	0	0	0	0		
	△	0	0	0	0	0	0	0	0	0	0	0	0	0	0	0	0	0	0	0	0	0	1		
	Darker	0	0	0	0	0	0	0	0	0	0	0	0	0	0	0	0	0	0	0	0	0	1		
	△	↑								↑								↑							
	▽	↓								↓								↓							
	Brighter	0	0	0	0	0	0	0	0	0	0	0	0	0	0	0	0	1	1	1	1	1	1	0	
	▽	0	0	0	0	0	0	0	0	0	0	0	0	0	0	0	0	1	1	1	1	1	1	0	
	Blue	0	0	0	0	0	0	0	0	0	0	0	0	0	0	0	0	1	1	1	1	1	1	1	
Gray Scale of White	Black	0	0	0	0	0	0	0	0	0	0	0	0	0	0	0	0	0	0	0	0	0	0		
	△	0	0	0	0	0	0	1	0	0	0	0	0	0	0	1	0	0	0	0	0	0	1		
	Darker	0	0	0	0	0	0	1	0	0	0	0	0	0	1	0	0	0	0	0	0	0	1		
	△	↑								↑								↑							
	▽	↓								↓								↓							
	Brighter	1	1	1	1	1	1	0	1	1	1	1	1	1	1	0	1	1	1	1	1	1	0	1	
	▽	1	1	1	1	1	1	1	0	1	1	1	1	1	1	1	0	1	1	1	1	1	1	0	
	White	1	1	1	1	1	1	1	1	1	1	1	1	1	1	1	1	1	1	1	1	1	1	1	





### 8.0 Power Sequence

To prevent a latch-up or DC operation of the LCD module, the power on/off sequence shall be as shown below:-

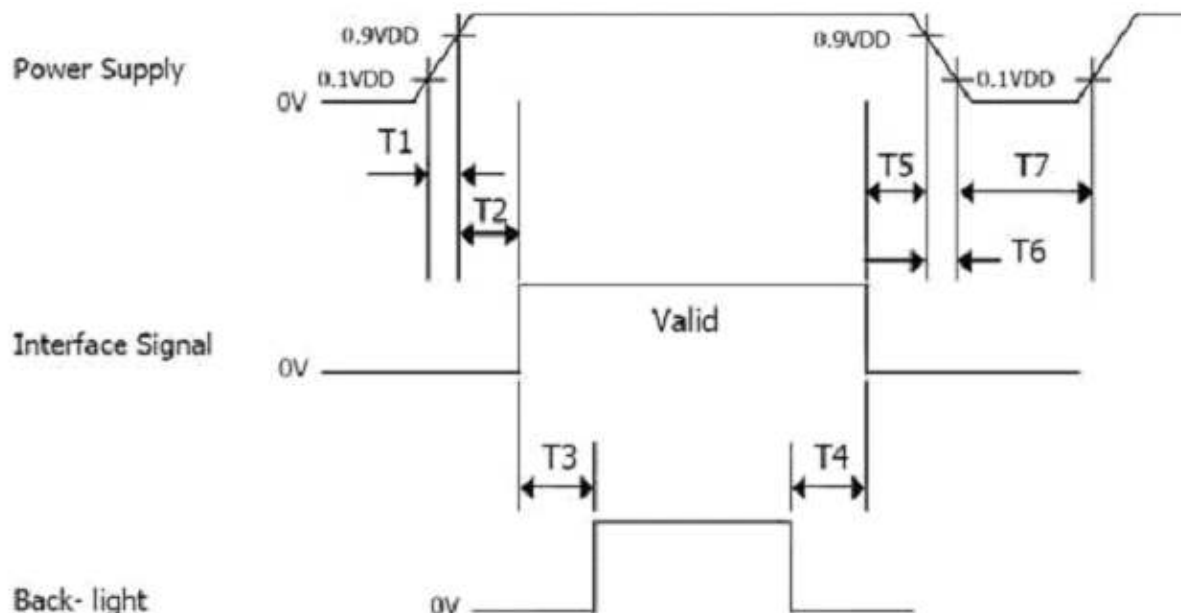

Parameter	Values			Units
	Min	Typ	Max	
T1	0.5	-	10	ms
T2	0	-	50	ms
T3	200	-	-	ms
T4	200	-	-	ms
T5	0.5	-	50	ms
T6	0	-	10	ms
T7	500	-	-	ms

Notes:

1. When the power supply VDD is 0V, keep the level of input signals on the low or keep high impedance.
2. Do not keep the interface signal high impedance when power is on. Backlight must be turn on after power for logic and interface signal are valid.



9.0 Reliability Test Condition

Item		Test Condition
Operating	High Temperature	65degC, 240 hrs
	Low Temperature	-20degC,240 hrs
Storage	High Temperature	80degC, 240hrs and recovery for 2hrs
	Low Temperature	-30degC, 240hrs and recovery for 2hrs
	High Temperature and High Humidity	50degC, 90%RH, 240hrs and recovery for 2 hrs
Thermal	Cycle	RT → 30degC → Rt → 80degC → RT 0min 30min 5min 30min 5min 50 cycles (Power off)
	Shock	RT → 30degV → 80degC 0min 30min 30min 50 cycles (Power off)

Note: Rt means Room temperature



10.0 Inspection Criteria

No	Defect	Definition of defect	Inspection Criteria														
1	a) Definition of dot	<p>The size of defective dot over 1/2 of whole is regards as one defective dot.</p> <p>Smaller than 1/2      Larger than 1/2</p> <p>R G B      R G B</p> <p>'No dot defect' (ignore)      '1 dot defect' (counted)</p>	<p>A – Viewing area B – Viewing area C – Outside Viewing area</p>														
	b) Bright Dot	Dot appear bright and unchanged in size when LCD panel is displaying black pattern	<table border="1"> <thead> <tr> <th>Defect</th> <th>A</th> <th>B</th> <th>C</th> </tr> </thead> <tbody> <tr> <td>Bright Dot</td> <td>1</td> <td>1</td> <td rowspan="3">NC</td> </tr> <tr> <td>Dark Dot</td> <td>2</td> <td>2</td> </tr> <tr> <td>Total</td> <td colspan="2">4</td> </tr> </tbody> </table> <p>NC – Not Count</p>	Defect	A	B	C	Bright Dot	1	1	NC	Dark Dot	2	2	Total	4	
	Defect	A	B	C													
	Bright Dot	1	1	NC													
Dark Dot	2	2															
Total	4																
c) Dark Dot	Dot appear dark and unchanged in size when LCD panel is displaying pure color (RED, GREEN or BLUE) pattern	<table border="1"> <thead> <tr> <th>Defect</th> <th>A</th> <th>B</th> <th>C</th> </tr> </thead> <tbody> <tr> <td>Bright Dot</td> <td>1</td> <td>1</td> <td rowspan="3">NC</td> </tr> <tr> <td>Dark Dot</td> <td>2</td> <td>2</td> </tr> <tr> <td>Total</td> <td colspan="2">4</td> </tr> </tbody> </table> <p>NC – Not Count</p>	Defect	A	B	C	Bright Dot	1	1	NC	Dark Dot	2	2	Total	4		
Defect	A	B	C														
Bright Dot	1	1	NC														
Dark Dot	2	2															
Total	4																
d) 2 dot adjacent	<p>1 pair = 2 dots</p> <p>Type 1      Type 2</p> <p>Type 3</p>	<table border="1"> <thead> <tr> <th>Defect</th> <th>Acc. Count</th> </tr> </thead> <tbody> <tr> <td>2 Bright dot Adjacent</td> <td>0</td> </tr> <tr> <td>2 Dark dot Adjacent</td> <td>1</td> </tr> </tbody> </table>	Defect	Acc. Count	2 Bright dot Adjacent	0	2 Dark dot Adjacent	1									
Defect	Acc. Count																
2 Bright dot Adjacent	0																
2 Dark dot Adjacent	1																
2	<p>Black spot White Spot Bright spot Pin Hole Foreign Particle</p> <p>-Black/Dark/Bright Spot is points on display which appear dark/bright and usually result from contamination - These defect do not vary in size intensity (contrast) when contras is varied.</p> <p><math>D=(a+b)/2(mm)</math></p>	<table border="1"> <thead> <tr> <th>Defect Category</th> <th>A</th> <th>B</th> </tr> </thead> <tbody> <tr> <td><math>D &lt; 0.10</math></td> <td>NC</td> <td rowspan="4">NC</td> </tr> <tr> <td><math>0.10 \leq D \leq 0.20</math></td> <td>2</td> </tr> <tr> <td><math>0.20 \leq D \leq 0.30</math></td> <td>1</td> </tr> <tr> <td><math>D &gt; 0.30</math></td> <td>0</td> </tr> </tbody> </table>	Defect Category	A	B	$D < 0.10$	NC	NC	$0.10 \leq D \leq 0.20$	2	$0.20 \leq D \leq 0.30$	1	$D > 0.30$	0			
Defect Category	A	B															
$D < 0.10$	NC	NC															
$0.10 \leq D \leq 0.20$	2																
$0.20 \leq D \leq 0.30$	1																
$D > 0.30$	0																
3	<p>Black Line White line Particle between POL and Glass Scratch on Glass</p>	<table border="1"> <thead> <tr> <th>Defect Category</th> <th>A</th> <th>B</th> </tr> </thead> <tbody> <tr> <td><math>W &lt; 0.03</math></td> <td>NC</td> <td rowspan="3">NC</td> </tr> <tr> <td><math>0.03 \leq W \leq 0.08, L \leq 2.0</math></td> <td>2</td> </tr> <tr> <td><math>W &gt; 0.08</math></td> <td>0</td> </tr> </tbody> </table>	Defect Category	A	B	$W < 0.03$	NC	NC	$0.03 \leq W \leq 0.08, L \leq 2.0$	2	$W > 0.08$	0					
Defect Category	A	B															
$W < 0.03$	NC	NC															
$0.03 \leq W \leq 0.08, L \leq 2.0$	2																
$W > 0.08$	0																
4	<p>POL Bubble POL Dented</p>	<table border="1"> <thead> <tr> <th>Defect Category</th> <th>A</th> <th>B</th> </tr> </thead> <tbody> <tr> <td><math>D &lt; 0.20</math></td> <td>NC</td> <td rowspan="4">NC</td> </tr> <tr> <td><math>0.20 \leq D \leq 0.30</math></td> <td>3</td> </tr> <tr> <td><math>0.30 \leq D \leq 0.50</math></td> <td>2</td> </tr> <tr> <td><math>D &gt; 0.5</math></td> <td>0</td> </tr> </tbody> </table>	Defect Category	A	B	$D < 0.20$	NC	NC	$0.20 \leq D \leq 0.30$	3	$0.30 \leq D \leq 0.50$	2	$D > 0.5$	0			
Defect Category	A	B															
$D < 0.20$	NC	NC															
$0.20 \leq D \leq 0.30$	3																
$0.30 \leq D \leq 0.50$	2																
$D > 0.5$	0																
5	<p>Mura (50% Grey)</p>	<p>Judged by Limit sample</p>															



## 11.0 Precaution and Limited Warranty

### 1. Handling Precautions

- a. The display panel is made of glass and polarizer. As glass is fragile. It tends to chip during handling especially on the edges. Please avoid dropping or jarring. Do not subject it to a mechanical shock of impact or by dropping it.
- b. If the display panel is damaged and the liquid crystal substance leaks out, be sure not to get any in your mouth. If the substance is in contact with your skin or clothes, wash it off using soap and water.
- c. Do not apply excessive force to the display surface or the adjoining areas since this may cause the color tone to vary. Do not touch the display with bare hands. This will stain the display area and degrade the insulation between terminals. Scratch and dents may occur on polarizer too.
- d. The polarizer covering the display surface of the LCD module is soft and easily scratched. Handle this polarizer carefully. Do not touch, push or rub the exposed polarizers with anything harder than a HB pencil lead (glass, tweezers, etc.). Do not put or attach anything on the display area to avoid leaving marks on it. Condensation on the surface and contact with terminals due to cold will damage, stain or dirty the polarizer. After products are tested at low temperature they must be warmed up in a container before coming in to contact with room temperature air.
- e. If the display surface becomes contaminated, breathe on the surface and gently wipe it with a soft dry cloth. If it is heavily contaminated, moisten cloth with one of the following solvents
  - Isopropyl alcohol
  - Ethyl alcohol
  - Do not scrub hard to avoid damaging the display surface.
- f. Solvents other than those above-mentioned may damage the polarizer. Especially, do not use the following.
  - Water
  - Ketone
  - Aromatic solvents
  - Wipe off saliva or water drops immediately, contact with water over a long period of time may cause deformation or colour fading. Avoid contact with oil and fats.
- g. Exercise care to minimize corrosion of the electrode. Corrosion of the electrodes is accelerated by water droplets, moisture condensation or a current flow in a high-humidity environment.
- h. Install the LCD Module by using the mounting holes. When mounting the LCD module make sure it is free of twisting, warping and distortion. In particular, do not forcibly pull or bend the I/O cable or the backlight cable.
- i. Do not attempt to disassemble or process the LCD module.
- j. NC terminal should be open. Do not connect anything.
- k. If the logic circuit power is off, do not apply the input signals.
- l. Electro-Static Discharge Control. Since this module uses a CMOS LSI, the same careful attention should be paid to electrostatic discharge as for an ordinary CMOS IC. To prevent destruction of the elements by static electricity, be careful to maintain an optimum work environment.
  - Before removing LCM from its packing case or incorporating it into a set, be sure the module and your body have the same electric potential. Be sure to ground the body when handling the LCD modules.
  - Tools required for assembly, such as soldering irons, must be properly grounded. Make certain the AC power source for the soldering iron does not leak. When using an electric screwdriver to attach LCM, the screw driver should be of ground potentiality to minimize as much as possible any



transmission of electromagnetic waves produced sparks coming from the commutator of the motor.

- To reduce the amount of static electricity generated, do not conduct assembly and other work under dry conditions. To reduce the generation of static electricity be careful that the air in the work environment is not too dry. A relative humidity of 50%-60% is recommended. As far as possible make the electric potential of your work clothes and that of the work bench the ground potential.
  - The LCD module is coated with a film to protect the display surface. Exercise care when peeling off this protective film since static electricity may be generated.
- m. Since LCM has been assembled and adjusted with a high degree of precision, avoid applying excessive shocks to the module or making any alterations or modifications to it.
- Do not alter, modify or change the shape of the tab on the metal frame.
  - Do not make extra holes on the printed circuit board, modify its shape or change the positions of components to be attached.
  - Do not damage or modify the pattern writing on the printed circuit board.
  - Absolutely do not modify the zebra rubber strip (conductive rubber) or heat seal connector.
  - Except for soldering the interface, do not make any alterations or modifications with a soldering iron.
  - Do not drop, bend or twist the LCM.

**2. Storage Precautions**

When storing the LCD modules, the following precaution are necessary.

- a. Store them in a sealed polyethylene bag. If properly sealed, there is no need for the desiccant.
- b. Store them in a dark place. Do not expose to sunlight or fluorescent light, keep the temperature between 0°C and 35°C, and keep the relative humidity between 40%RH and 60%RH.
- c. The polarizer surface should not come in contact with any other objects.

**3. Others**

- a. Liquid crystals solidify under low temperature (below the storage temperature range) leading to defective orientation or the generation of air bubbles (black or white). Air bubbles may also be generated if the module is subject to a low temperature.
- b. If the LCD modules have been operating for a long time showing the same display patterns, the display patterns may remain on the screen as ghost images and a slight contrast irregularity may also appear. A normal operating status can be regained by suspending use for some time. It should be noted that this phenomenon does not adversely affect performance reliability.
- c. To minimize the performance degradation of the LCD modules resulting from destruction caused by static electricity etc. Exercise care to avoid holding the following sections when handling the modules.
  - Exposed area of the printed circuit board.

Terminal electrode sections.

**4. Using LCD Modules**

- a. Installing LCD Modules

The hole in the printed circuit board is used to fix LCM as shown in the picture below.

Attend to the following items when installing the LCM.



- b. Cover the surface with a transparent protective plate to protect the polarizer and LC cell.

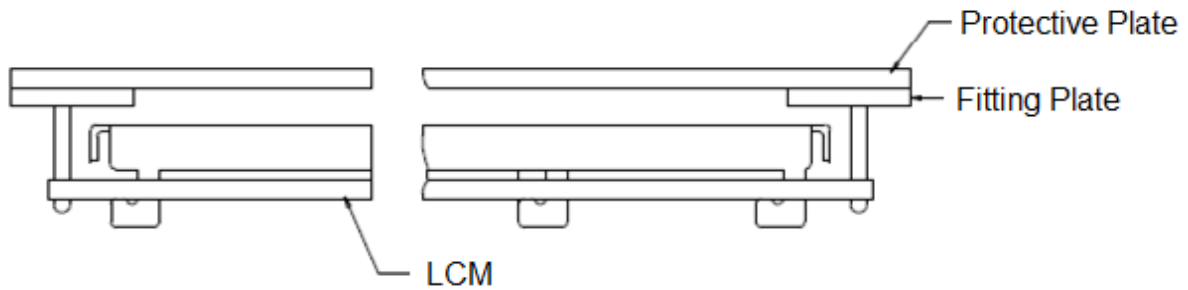

- c. When assembling the LCM into other equipment, the spacer to the bit between the LCM and the fitting plate should have enough height to avoid causing stress to the module surface, refer to the individual specifications for measurements. The measurement tolerance should be 0.1mm.
- d. Precaution for assemble the module with BTB connector:  
Please note the position of the male and female connector position, don't assemble or assemble like the method which the following picture shows

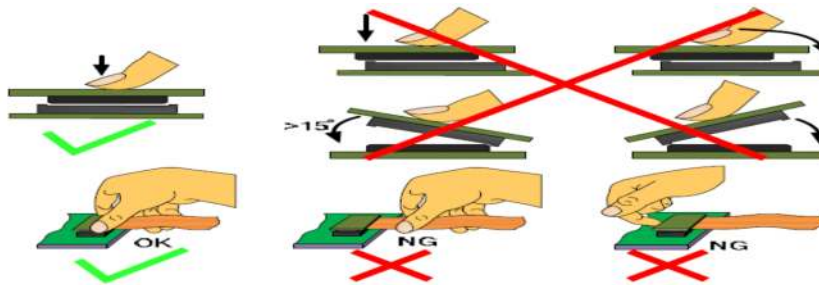

5. Precaution for soldering the LCM

	Manual soldering	Machine drag soldering	Machine press soldering
No RoHS Product	290°C ~350°C. Time: 3-5S.	330°C ~350°C. Speed: 4-8 mm/s.	300°C ~330°C. Time: 3-6S. Press: 0.8~1.2Mpa
RoHS Product	340°C ~370°C. Time: 3-5S.	350°C ~370°C. Time: 4-8 mm/s.	330°C ~360°C. Time: 3-6S. Press: 0.8~1.2Mpa

- a. If soldering flux is used, be sure to remove any remaining flux after finishing the soldering operation (This does not apply in the case of a non-halogen type of flux). It is recommended that you protect the LCD surface with a cover during soldering to prevent any damage due to flux spatters.
- b. When soldering the electroluminescent panel and PC board, the panel and board should not be detached more than three times. This maximum number is determined by the temperature and time conditions mentioned above, though there may be some variance depending on the temperature of the soldering iron.
- c. When removing the electroluminescent panel from the PC board, be sure the solder has completely melted, the soldered pad on the PC board could be damaged.



6. Precautions for Operation

- a. Viewing angle varies with the change of liquid crystal driving voltage (VLCD). Adjust VLCD to show the best contrast.
- b. It is recommended to drive LCD's within the specified voltage limit since over limit will cause shorter LCD life. An electrochemical reaction due to direct current causes LCD-deterioration. Avoid the use of direct current drive.
- c. Response time will be extremely delayed at lower temperature compared to room operating temperature range and on the other hand, at higher temperature LCD shows dark color in them. However those phenomena do not mean malfunction. The LCD will return to normal performance when ambient temperature revert to room condition.
- d. If the display area is pushed hard during operation, the display will become abnormal. However, it will return to normal if it is turned off and on.
- e. A slight dew depositing on terminals is a cause for electro-chemical reaction resulting in terminal open circuit.
- f. Input logic voltage before apply analogue high voltage such as LCD driving voltage when power on. Remove analogue high voltage before logic voltage when power off the module. Input each signal after the positive/negative voltage becomes stable.
- g. Please keep the temperature within the specified range for use and storage. Polarization degradation, bubble generation or polarizer peel-off may occur with high temperature and high humidity.

7. Safety

- a. It is recommended to crush damaged or unnecessary LCDs into pieces and wash them off with solvents such as acetone and ethanol, which should later be burned.
- b. If any liquid leaks out of a damaged glass cell and comes in contact with the hands, wash off thoroughly with soap and water.

8. Limited Warranty

Unless otherwise agreed between Crystal Clear Technology and customer, Crystal Clear Technology will replace or repair any of its LCD and LCM which is found to be defective electrically and visually when inspected in accordance with Crystal Clear Technology acceptance standards, for a period of one year from date of shipment. Confirmation of such date shall be based on freight documents. The warranty liability of Crystal Clear Technology is limited to repair and/or replacement on the terms set forth above. Crystal Clear Technology will not responsible for any subsequent or consequential events.

9. Return LCM under Warranty

No warranty can be granted if the precautions stated above have been disregarded. The typical examples of violations are:

- Broken LCD glass
- PCB eyelet's damaged or modified
- PCB conductors damaged
- Circuit modified in any way, including addition of components.
- PCB tampered with by grinding, engraving or painting varnish.
- Soldering to, or modifying the bezel in any manner.

Module repairs will be invoiced to customer upon mutual agreement. Modules must be returned with sufficient description of failure or defects. Any connectors or cable installed by customer must be removed completely without damaging the PCB eyelet's, conductors and terminals.

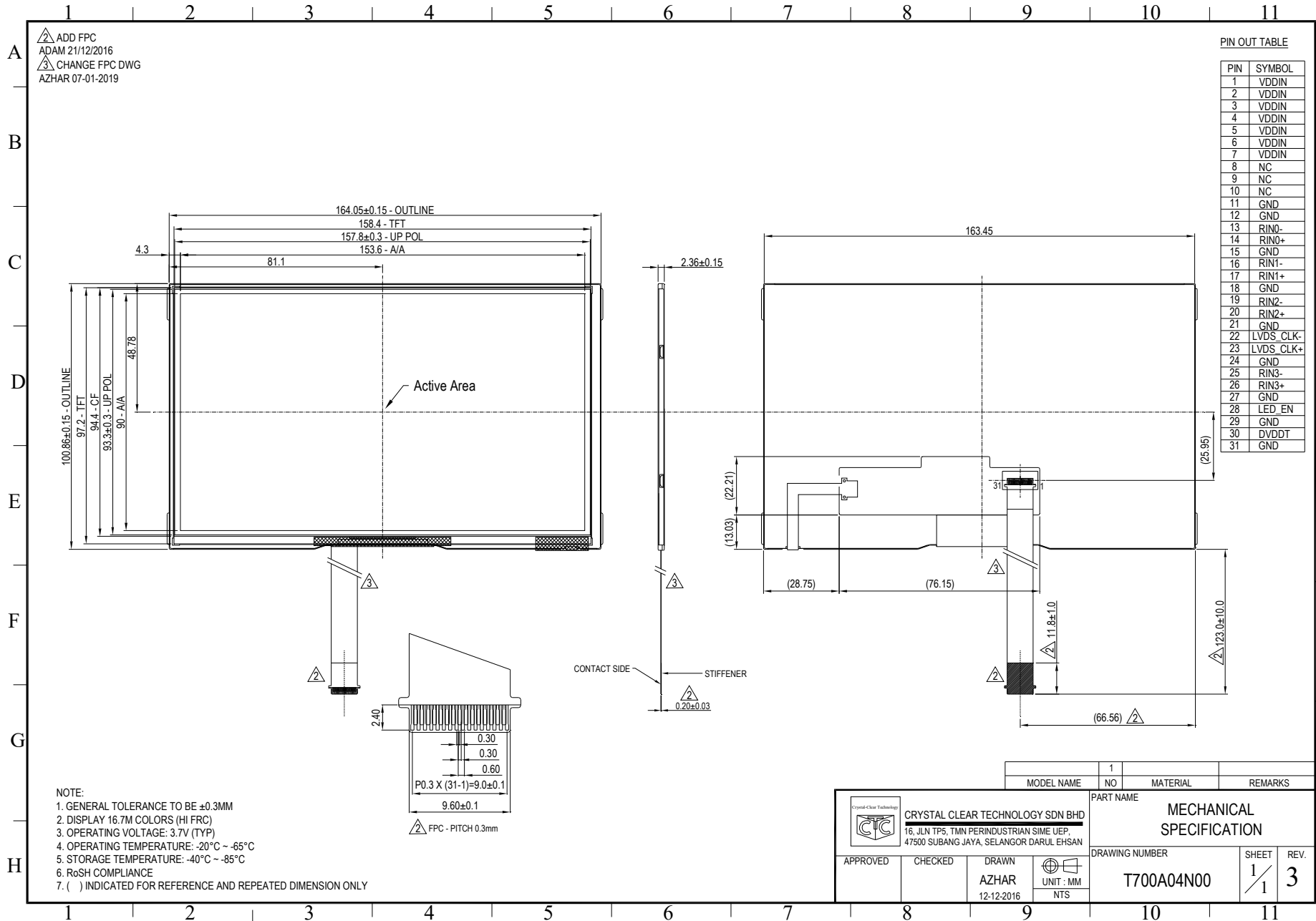



1 2 3 4 5 6 7 8 9 10 11

A  
 ADD FPC  
 ADAM 21/12/2016  
 REVISE PIN TABLE - CTP  
 AZHAR 21-04-2017  
 CHANGE LENS THICKNES  
 AZHAR 02-05-2017  
 ADD DIMENSION  
 AZHAR 04-01-2019

PIN OUT TABLE - TFT

PIN	SYMBOL
1	VDDIN
2	VDDIN
3	VDDIN
4	VDDIN
5	VDDIN
6	VDDIN
7	VDDIN
8	NC
9	NC
10	NC
11	GND
12	GND
13	RIN0-
14	RIN0+
15	GND
16	RIN1-
17	RIN1+
18	GND
19	RIN2-
20	RIN2+
21	GND
22	LVDS_CLK-
23	LVDS_CLK+
24	GND
25	RIN3-
26	RIN3+
27	GND
28	LED_EN
29	GND
30	DVDDT
31	GND

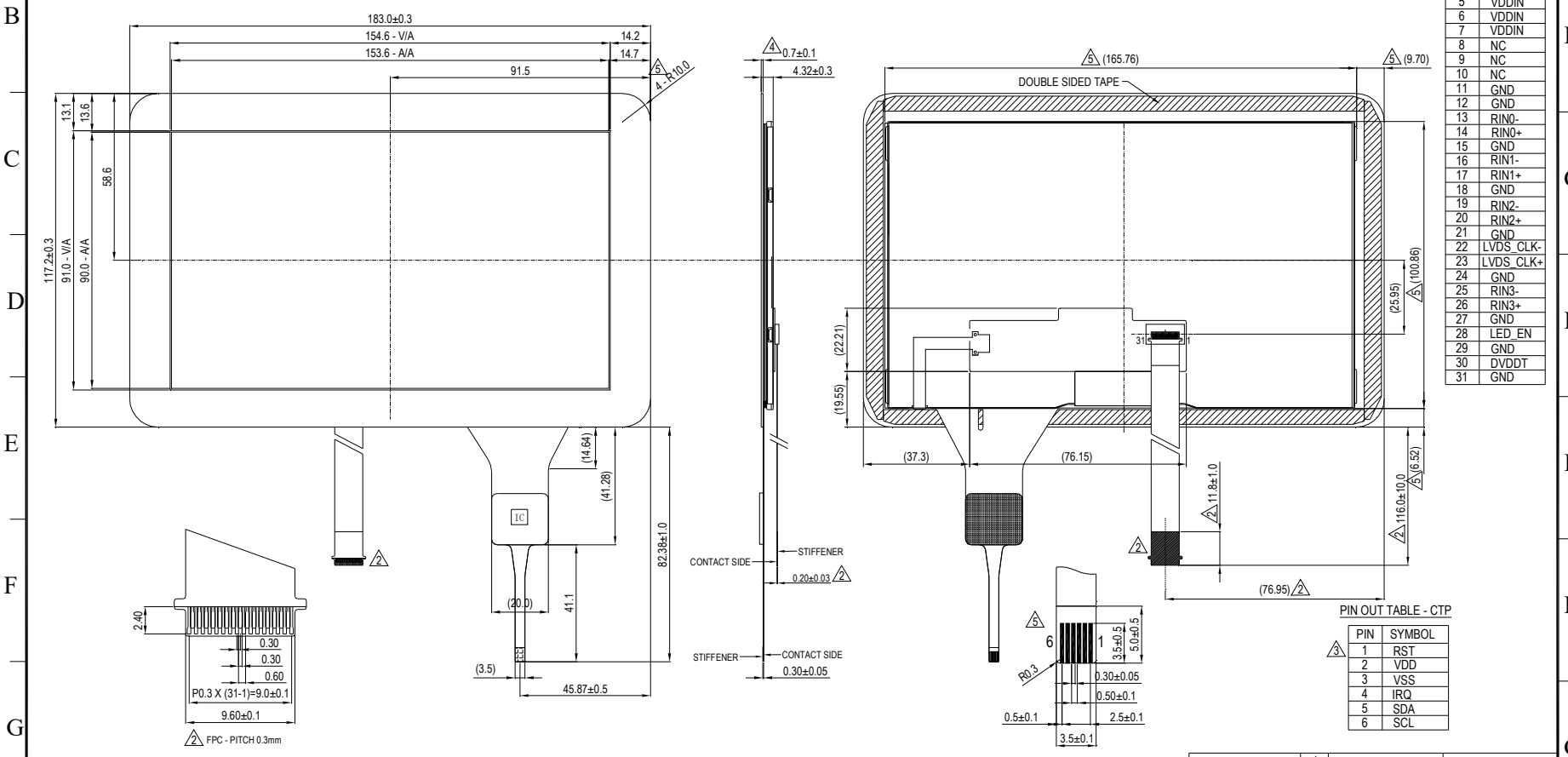

NOTE:  
 1. GENERAL TOLERANCE TO BE ±0.3MM  
 2. DISPLAY 16.7M COLORS (HI FRC)  
 3. OPERATING VOLTAGE: 3.7V (TYP)  
 4. OPERATING TEMPERATURE: -20°C ~ 65°C  
 5. STORAGE TEMPERATURE: -40°C ~ -85°C  
 6. RoSH COMPLIANCE  
 7. ( ) INDICATED FOR REFERENCE AND REPEATED DIMENSION ONLY

PIN OUT TABLE - CTP

PIN	SYMBOL
1	RST
2	VDD
3	VSS
4	IRQ
5	SDA
6	SCL

MODEL NAME	NO	MATERIAL	REMARKS
	1		

		<b>CRYSTAL CLEAR TECHNOLOGY SDN BHD</b> 16, JLN TP5, TMN PERINDUSTRIAN SIME UEP, 47500 SUBANG JAYA, SELANGOR DARUL EHSAN		<b>MECHANICAL SPECIFICATION</b>	
APPROVED	CHECKED	DRAWN		DRAWING NUMBER	SHEET
		AZHAR	UNIT: MM	T700A04C00C	1/1
		04-02-2016	NTS		REV. 5

1 2 3 4 5 6 7 8 9 10 11

A  
B  
C  
D  
E  
F  
G  
H

# Crystal Clear Technology

## Product Specification

**Crystal Clear Technology sdn. bhd.**

16Jalan TP5—Taman Perindustrian Sime UEP  
47600 Subang Jaya—Selangor DE  
Malaysia. T: +603 80247099 F: +603 80247098

---



# Contents

No	Title	Page
1	INTRODUCTION	2
2	GENERAL DESCRIPTION	2
3	ABSOLUTE MAXIMUM RATING	3
4	INTERFACE CHARACTERISTICS	3
5	ELECTRICAL CHARACTERISTICS	4
6	12C INTERFCE	4
7	MECHANICAL SPECIFICATION	6



## 1. Introduction

The purpose of this specification is defined the general provision and quality requirement apply to 7 inch Capacitive Touch module integrated by Crystal Clear Technology. This document, together with the module drawing, is the highest level specification for this product. When users touch module by finger, the module can send coordinates of point at the contact point to host. The finger position information is sent to host by I2C bus which is determined by host through IRQ line.

## 2. General Description

This document contains the Capacitive Touch module specification. The maximum rating, characteristics, hardware, and inspection of the module are described in the subsequent sections. In special, I2C protocol will be introduced in detail.

### 2.1. Touch sensor characteristics

- Technology: Use the character of capacitive among the touch electrodes on touch panel to identify the positions of touch signals
- Touch method: Ten fingers multi touch with pressure sensing
- Interface: I2C

### 2.2. General Specification

Item	Specification	Unit
Screen Diagonal	7.0	Inch
Applied Resolution	1024 x 600	pixel
Module Outline	100(H) x 164.1(W) x 1.4(T) (Excluded FPC)	Mm
Touch Area	(H) x (W)	Mm
Cover Lens Material	Glass	-
Transparency	85	%
Origin	-	-
Controller	GT911	-



### 3. Absolute Maximum Ratings

Absolute Maximum rating of touch panel module is as following

Symbol	Parameter	Value	Unit
V <sub>CORE</sub>	Supply Voltage for Logic	-0.3 to +2.8	V
V <sub>DDIO</sub>	Supply Voltage for I/O	-0.3 to +3.3	V
T <sub>A</sub>	Operating Temperature	-20 to +85	°C
T <sub>STG</sub>	Storage Temperature	-30 to +85	°C

Note: If the module exceeds the absolute maximum ratings, it may be damaged permanently. Also, if the module operated with the absolute maximum ratings for a long time, its reliability may drop.

### 4. Electrical Characteristics

DC Characteristics (Unless otherwise specified, Voltage Referenced to V<sub>SS</sub>, T<sub>A</sub> = -20 to 85°C)

Symbol	Parameter	Conditions	Min	Typ	Max	Unit
V <sub>AVDD</sub>	Analog power supply		2.8	-	3.3	V
V <sub>DDIO</sub>	Digital I/O power supply		1.8	-	3.3	V
I <sub>DD</sub>	Operating mode current		-	8	14.5	mA
I <sub>GR</sub>	Green mode current		-	3.3	-	mA
I <sub>sleep</sub>	Sleep mode current		70	-	120	uA
V <sub>OH1</sub>	Logic High Output Voltage		0.85* V <sub>DDIO</sub>	-	-	V
V <sub>OL1</sub>	Logic Low Output Voltage		-	-	0.15* V <sub>DDIO</sub>	V
V <sub>IH1</sub>	Logic High Input voltage		0.75* V <sub>DDIO</sub>	-	V <sub>DDIO</sub> +3	V
V <sub>IL1</sub>	Logic Low Input voltage		-0.3	-	0.25* V <sub>DDIO</sub>	V



## 5. Pin Definition

### Recommended connector: FH33-6S-0.5SH (Hirose)

No.	Symbol	I/O	Function
1	RST	I	Sensor system global reset
2	VDD	P	Power supply
3	VSS	P	Ground
4	IRQ	O	Sensor data ready request
5	SDA	I/O	I2C serial data
6	SCL	I	I2C serial clock

## 6. I2C Interface

Touch panel is used as I2C Slave Device, I2C Slave address is 0x14.

### 6.1. Interface Diagram

The system block diagram is as shown in below. There are three communication pins connected between CPU and Touch Panel Module which are including external interrupt IRQ, I2C pins SCL and SDA. The IRQ is active low while the touch state is calculated by Touch Panel Module and the touch information can be translated via I2C communication interface. The I2C data format, protocol and report packet are described as following.

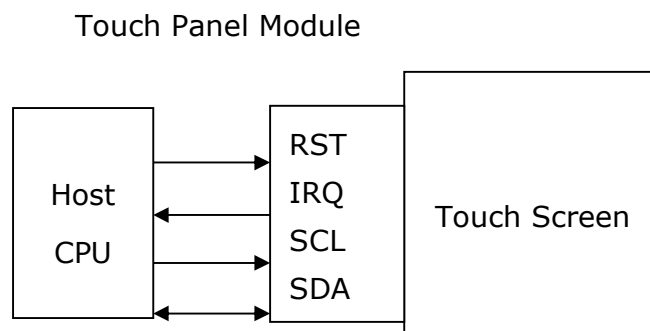



## 6.2. Timing Characteristic

Conditions:

VDD - VSS = 2.5 TO 3.3V

TA = 25°C

400Kbps transmission rate, 2K pull-up resistor

Symbol	Parameter	Min	Typ	Max	Unit
Tlo	SCL low period	1.3	-	-	US
thi	SCL high period	0.6	-	-	US
tst1	SCL setup time for Start condition	0.6	-	-	US
tst3	SCL setup time for Start condition	0.6	-	-	US
thd1	SCL setup time for Start condition	0.6	-	-	US
tst2	SDA setup time	0.1	-	-	US
thd2	SDA hold time	0	-	-	US

### Power On Timing:

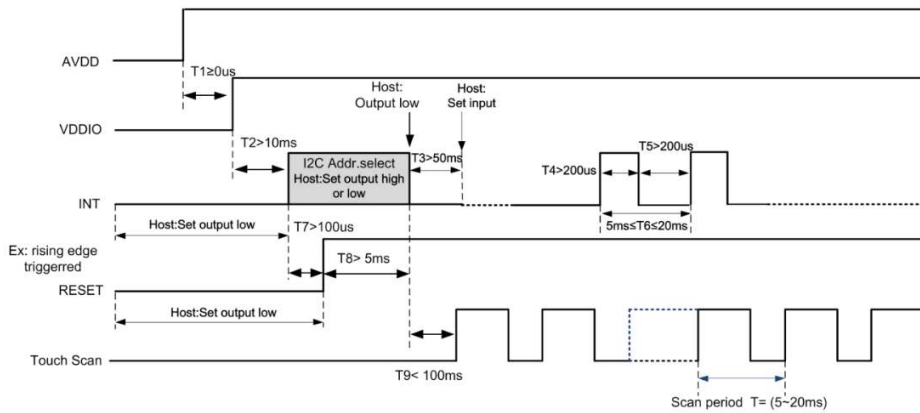

### Timing for host resetting

