

CRYSTAL CLEAR TECHNOLOGY

Product Specification

T700T09X00

(REVISION 7)

Crystal Clear Technology Sdn. Bhd.

16 Jalan TP5, Taman Perindustrian Sime UEP,

47600 Subang Jaya, Selangor DE

Tel: +603-80247099

Website: www.cct.com.my



1.0 Table of Contents

No	Title	Page
1	Table of Contents	1
2	Record of revision	2
3	General Specification	3
4	Absolute Maximum Ratings	4
5	Electrical Characteristics	5
6	Pin Assignment	7
7	Optical Characteristics	9
8	Timing Characteristics	12
9	Reliability Test Condition	14
10	Inspection Criteria	15
11	Precaution and Limited Warranty	16
12	Mechanical Specification	20
13	Attachment:	
	Capacitive Touch Panel Specification – TP0085	



2.0 Records of Revision

Rev	Date	Item	Page	Comment	Originator	Checked By
1.0	22.11.15			Initial Release	Azhar	Liew
2.0	08.12.15			Update mechanical drawing		
				Change IC	Azhar	Liew
3.0	28.01.16			Change model name T700B09N00 to T700X09X00	Azhar	Azhar
4.0	01.03.16			Change viewing direction	Azhar	Azhar
5.0	10.05.16			Change model name T700X09X00 to T700T09X00, update reliability test, change inspection criteria, change precaution and limited warranty.	Adam	Azhar
6.0	9.11.17			Revise CTP Spec Revise Backlight Spec	Azhar	Azhar
7.0	13.11.17			Add recommended connector	Azhar	Azhar
8.0	28.12.18			Change brightness spec	Azhar	Azhar



3.0 General Specification

T700T09X00 is 7.0" color TFT-LCD (Thin Film Transistor Liquid Crystal Display) module composed of LCD panel, driver ICs control circuit, LED backlight. This display area contains 1024 x 600 pixels and can display up to 16M colors. This product compliant with RoHS environmental requirement.

Item	Contents	Unit	Note
LCD Type	7.0" TFT	-	
Display color	16M		1
Viewing Direction (Optimum View)	12	O 'Clock	
Viewing Direction (Grey Inversion)	6	O 'Clock	
Module size	165.4 X 105.7 X 2.78	mm	2
Active Area(W×H)	153.6 X 90.0	mm	
Number of Dots	1024×RGB×600	dots	
Driver IC	NT51008CH and NT52002H	-	
Backlight	27 White LEDs	pcs	
Brightness	350 (TYP)	cd/m2	
Interface Mode	LVDS	-	

Note1: Color tone is slightly changed by temperature and driving voltage.

Note2: FPC or wire are not included.

Note3: Brightness on LCD surface. Module with CTP or RTP, brightness will be about 20% (max) lower on the touch panel surface.

AVAILABLE OPTION

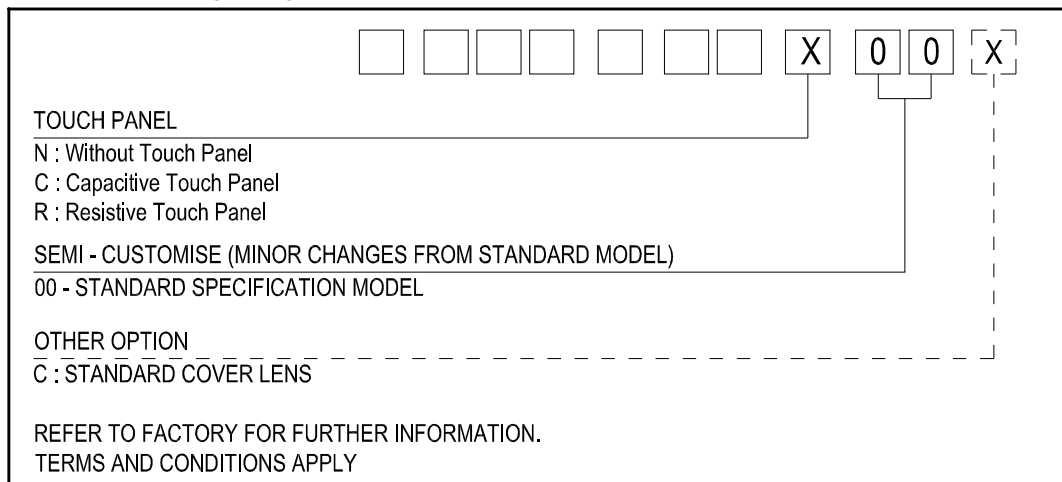



4.0 Absolute Maximum Ratings

4.1 Electrical Absolute Maximum ratings ($V_{ss} = 0V$, $T_a = 25^{\circ}C$)

Item	Symbol	Min.	Max.	Unit	Note
Power Voltage	DVDD	-0.3	5.0	V	
	AVDD	6.5	13.5	V	
	VGH	-0.3	42.0	V	
	VGL	-20.0	0.3	V	
	VGH-VGL		40.0	V	

Notes:

1. If the module is above these absolute maximum ratings. It may become permanently damaged.
2. VR Condition: Zener Diode: 20mA.
3. Please be sure users are grounded when handing LCD Module.

4.2 Environmental Absolute Maximum Ratings

Item	Storage		Operating		Note
	MIN.	MAX.	MIN.	MAX.	
Ambient Temperature	-30°C	80°C	-20°C	70°C	1,2
Humidity	-	-	-	-	3

1. The response time will become lower when operated at low temperature.
2. Background color changes slightly depending on ambient temperature. The phenomenon is reversible.
3. $T_a \leq 40^{\circ}C$ and 85%RH MAX.
($T_a > 40^{\circ}C$. Absolute humidity must be lower than the humidity of 85%RH at $40^{\circ}C$)



5.0 Electrical Characteristics and Instruction Code

5.1 Electrical Characteristics ($V_{ss} = 0V$, $T_a = 25^\circ C$)

Parameter	Symbol	Min	Typ	Max	Unit	Note
Power supply	DVDD	3.0	3.3	3.6	V	Note 2
	AVDD	10.8	11	11.2	V	
	VGH	19.7	20	20.3	V	
	VGL	-6.5	-6.8	-7.1	V	
Input signal voltage	VCOM	2.8	(3.8)	4.8	V	
Input logic high voltage	V _{IH}	0.7DVDD	-	DVDD	V	Note 3
Input logic low voltage	V _{IL}	0	-	0.3DVDD	V	

Note 1: DVDD and VGL must be applied first before we can apply VGH.

Note 2: DVDD setting should match the signals output voltage (refer to Note 3) of customer's system board.

Note 3: DCLK, HS, VS, RESET, U/D, L/R, DE, R0~R7, G0~G7, B0~B7, MODE, DITHB.

Note 4: VCOM (typ) is only a reference value, it must be adjusted (use VR) and optimized on each LCM.

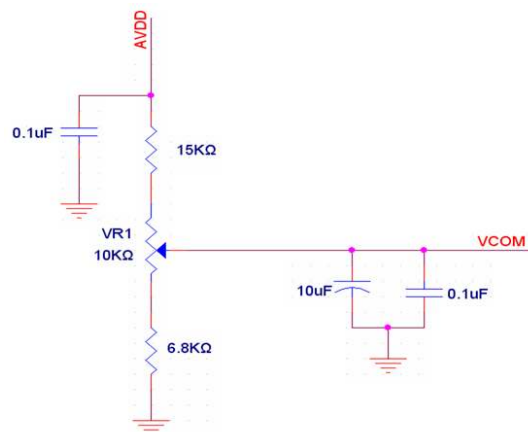

5.2 Current Consumption

Item	Symbol	Min	Typ	Max	Unit	remarks
Current for Driver	IGH	-	0.2	1	mA	VGH = 18.0V
	IGL	-	0.2	1	mA	VGL = -6.0V
	IDVDD	-	50	60	mA	DVDD = 3.3V
	IAVDD	-	25	30	mA	AVDD = 9.6V

5.3 Power Sequence

a. Power On

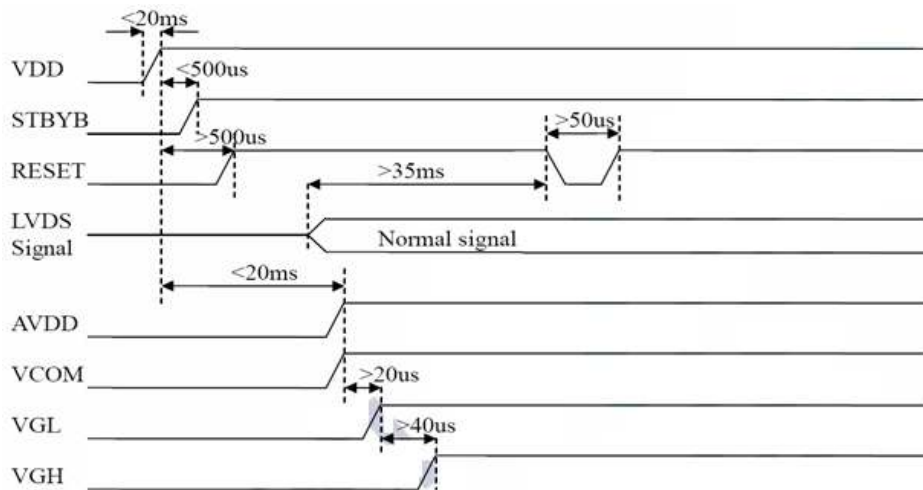

b. Power Off

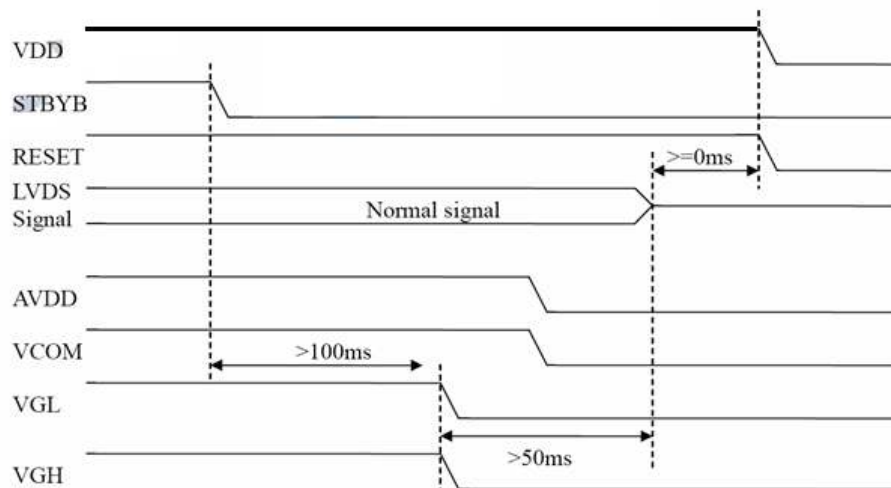

5.4 LED Backlight Specification ($V_{ss} = 0\text{V}$, $T_a = 25^\circ\text{C}$)

Item	Symbol	Condition	Min	Typ	Max	Unit	Note
Supply Voltage	V_{LED}	-	8.4	9.6	10.8	V	1
Supply Current	I_f	-	-	180	-	mA	
Led lifetime			30000				2

Note:

- $V_{LED} = V_{LED (+)} - V_{LED (-)}$.
- It is recommended that customer supply constant current to prolong the led lifetime and optimum led performance
- Definition of Lifetime: Luminance $< 50\%$ of initial Luminance
(Test condition: $T_a = 25^\circ\text{C}$, Constant current supply (typical Value))



6.0 Pin Assignment

Recommended connector : FH33-40S-0.5SH (HIROSE)

Pin No.	Symbol	I/O	Function	Remark
1	VCOM	P	Common Voltage	
2	VDD	P	Power Voltage for digital circuit	
3	VDD	P	Power Voltage for digital circuit	
4	NC	---	No connection	
5	Reset	I	Global reset pin	
6	STBYB	I	Standby mode, Normally pulled high STBYB = "1", normal operation STBYB = "0", timing controller, source driver will turn off, all output are High-Z	
7	GND	P	Ground	
8	RXIN0-	I	-LVDS differential data input	
9	RXIN0+	I	+ LVDS differential data input	
10	GND	P	Ground	
11	RXIN1-	I	-LVDS differential data input	
12	RXIN1+	I	+ LVDS differential data input	
13	GND	P	Ground	
14	RXIN2-	I	-LVDS differential data input	
15	RXIN2+	I	+ LVDS differential data input	
16	GND	P	Ground	
17	RXCLKIN-	I	-LVDS differential clock input	
18	RXCLKIN+	I	+ LVDS differential clock input	
19	GND	P	Ground	
20	RXIN3-	I	-LVDS differential data input	
21	RXIN3+	I	+ LVDS differential data input	
22	GND	P	Ground	
23	NC	---	No connection	
24	NC	---	No connection	
25	GND	P	Ground	
26	NC	---	No connection	
27	DIMO	O	Backlight CABC controller signal output	
28	SELB	I	6bit/8bit mode select	Note1
29	AVDD	P	Power for Analog Circuit	
30	GND	P	Ground	



31	LED-	P	LED Cathode	
32	LED-	P	LED Cathode	
33	L/R	I	Horizontal inversion	Note3
34	U/D	I	Vertical inversion	Note3
35	VGL	P	Gate OFF Voltage	
36	CABCEN1	I	CABC H/W enable	Note2
37	CABCEN0	I	CABC H/W enable	Note2
38	VGH	P	Gate ON Voltage	
39	LED+	P	LED Anode	
40	LED+	P	LED Anode	

I: input, O: output, P: Power

Note1: If LVDS input data is 6 bits, SELB must be set to High;

If LVDS input data is 8 bits, SELB must be set to Low.

Note2: When CABC_EN="00", CABC OFF.

When CABC_EN="01", user interface image.

When CABC_EN="10", still picture.

When CABC_EN="11", moving image.

When CABC off, don't connect DIMO, else connect it to backlight.

Note3: When L/R="0", set right to left scan direction.

When L/R="1", set left to right scan direction.

When U/D="0", set top to bottom scan direction.

When U/D="1", set bottom to top scan direction.

Note: Refer below figure for Definition of scanning direction.

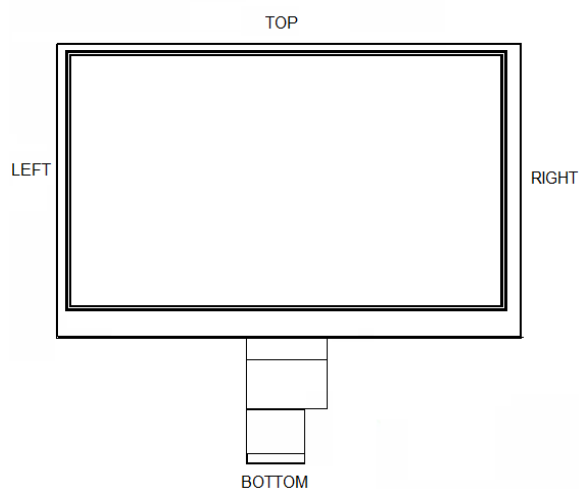

7.0 Electrical Characteristics

Items		Symbol	Condition	Min	Typ	Max	Unit	Remark
Response Time		Tr + Tf	$\Theta = 0^\circ$ $\varnothing = 0^\circ$ Ta = 25°C	-	25	50	ms	Note5
Contrast Ratio		Cr		500	700	-	-	Note4
Uniformity		Δ White		-	70	-	%	Note2
Surface Luminance		Lv		280	350	420	cd/m2	Note1
Viewing Angle		$\Theta_T = 90$	CR>10	60	70	-	°	Note3
		$\Theta_B = 270$		65	75	-		
		$\Theta_R = 0$		65	75	-		
		$\Theta_L = 180$		65	75	-		
CIE (X, Y) Chromaticity	White	X _W	$\Theta = 0^\circ$ $\varnothing = 0^\circ$ Ta = 25°C	0.26	0.29	0.30	-	Note6
		Y _W		0.26	0.29	0.30	-	
	Red	X _R		0.648	0.663	0.678	-	
		Y _R		0.310	0.325	0.340	-	
	Green	X _G		0.259	0.274	0.287	-	
		Y _G		0.587	0.602	0.617	-	
	Blue	X _B		0.119	0.134	0.149	-	
		Y _B		0.103	0.118	0.133	-	

Note: The parameter is slightly changed by temperature, driving voltage and material

Note 1: The data are measured after LEDs are turned on for 5 minutes. LCM displays full white. The brightness is the average value of 9 measured spots. Measurement equipment PR-705 (Φ8mm)

Measuring condition:

- Measuring surroundings: Dark room.
- Measuring temperature: Ta=25°C.
- Adjust operating voltage to get optimum contrast at the center of the display.

Measured value at the center point of LCD panel after more than 5 minutes while backlight turning on.

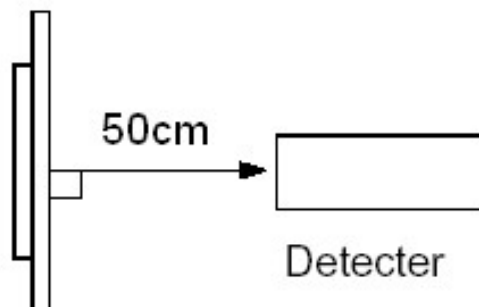

Note 2: The luminance uniformity is calculated by using following formula.

$$\Delta Bp = Bp (\text{Min.}) / Bp (\text{Max.}) \times 100 (\%)$$

$Bp (\text{Max.})$ = Maximum brightness in 9 measured spots
 $Bp (\text{Min.})$ = Minimum brightness in 9 measured spots.

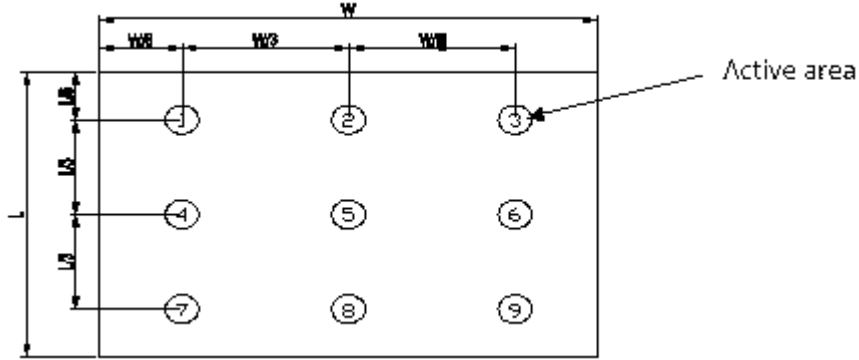

Note 3: The definition of viewing angle:

Refer to the graph below marked by θ and ϕ

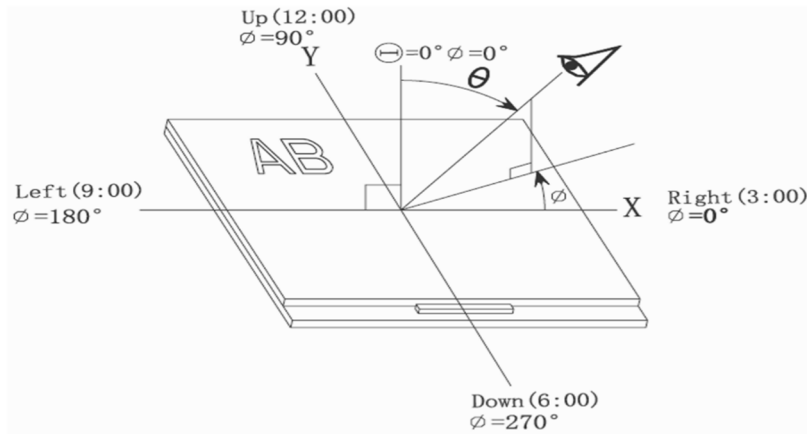

Note 4: Definition of contrast ratio. (Test LCD using DMS501)

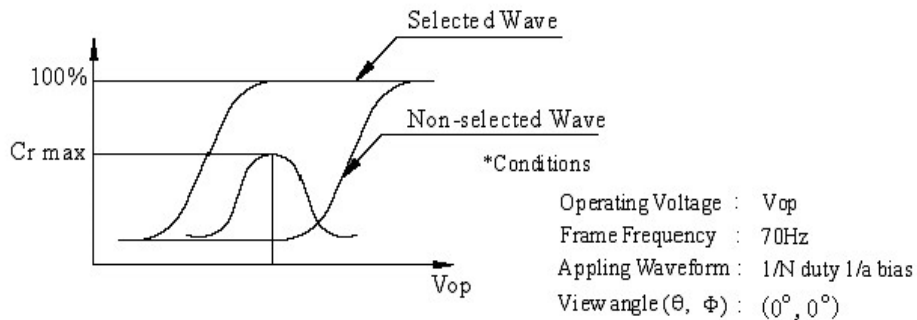

$$\text{Contrast ratio (Cr)} = \frac{\text{Brightness of selected dots}}{\text{Brightness of non-selected dots}}$$



Note 5: Definition of Response time. (Test LCD using DMS501):

The output signals of photo detector are measured when the input signals are changed from “black” to “white”(falling time) and from “white” to “black”(rising time), respectively. The response time is defined as the time interval between the 10% and 90% of amplitudes. Refer to figure as below.

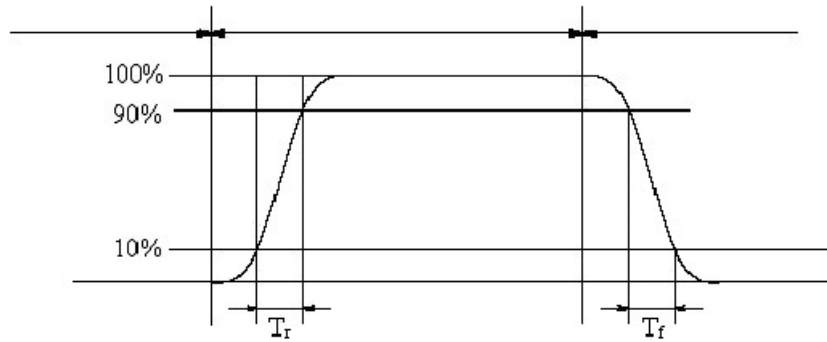

The Definition of response time

Note 6: Definition of Color of CIE Coordinate and NTSC Ratio.

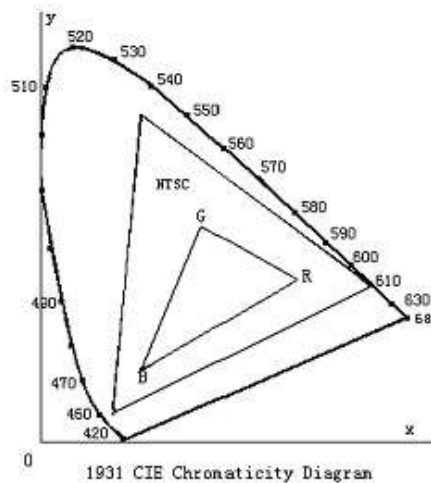

Note 7: Definition of cross talk.

Cross talk ratio (%) = [pattern A Brightness-pattern B Brightness]/pattern A

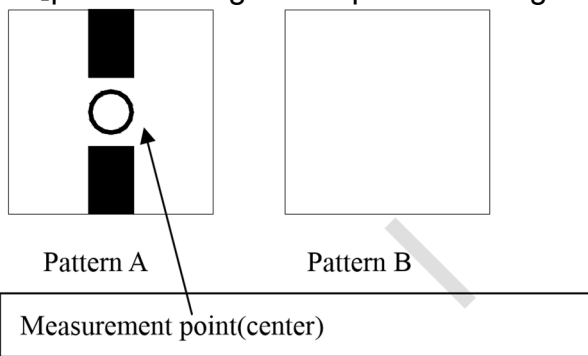

Electric volume value = 3F+/-3Hex

8.0 Timing Characteristics

8.1 AC Electrical Characteristics

Item	Symbol	values			Unit	Remark
		Min	Typ	Max		
Clock frequency	Rxfclk	40.8	51.2	71	MHz	
Input data skew margin	Trskm	500		-	ps	
Clock high time	Tlvch	-	$4/(7 * RxFCLK)$	-	ns	
Clock low time	Tlvcl	-	$3/(7 * RxFCLK)$	-	ns	

8.2 Input Clock and Data Timing Diagram

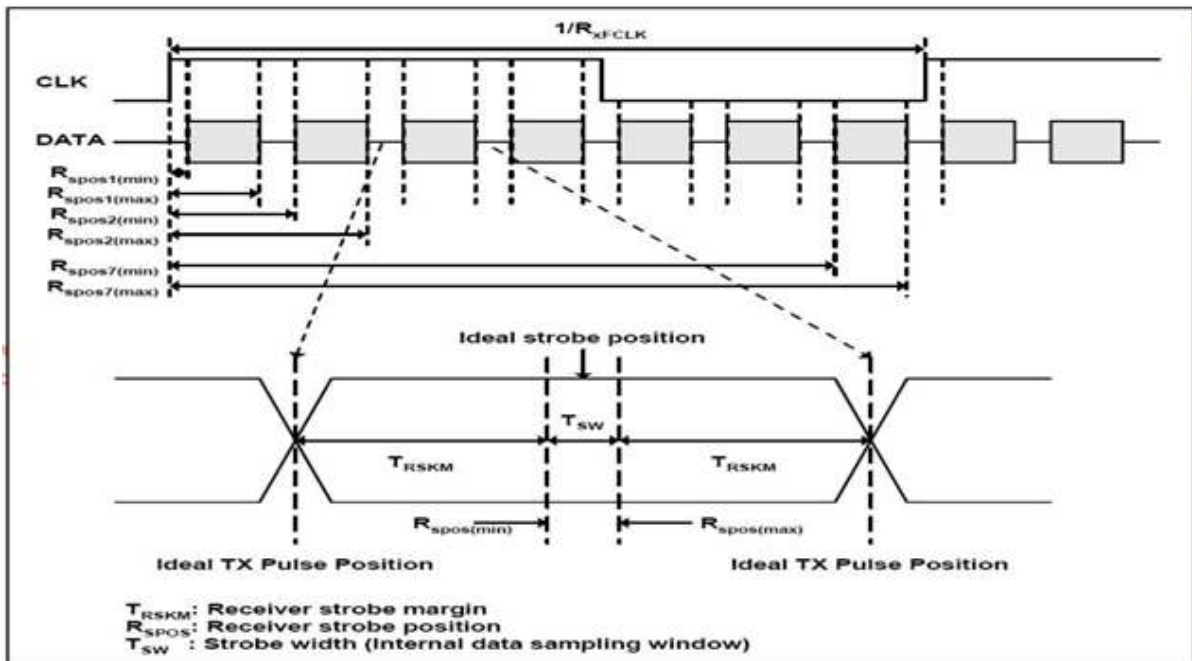
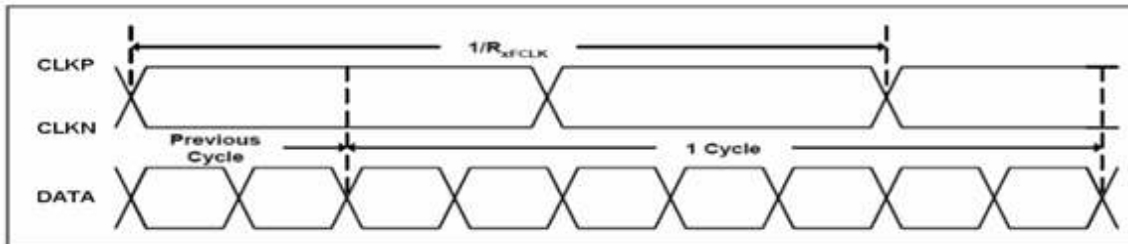

8.3 DC Electrical Characteristics

Parameter	Symbol	Values			Unit	Remark
		Min	Typ	Max		
Differential input high Threshold voltage	RxVTH	-	-	+0.1	V	RXVCM=1.2V
Differential input low Threshold voltage	RxVTH	-0.1	-	-	V	
Input voltage range (singled-end)	RxVIN	0	-	2.4	V	
Differential input common mode voltage	RxVCM	$ VID /2$	-	$2.4- VID /2$	V	
Differential voltage	$ VID $	0.2	-	0.6	V	
Differential input leakage current	RVxliz	-10	-	+10	uA	

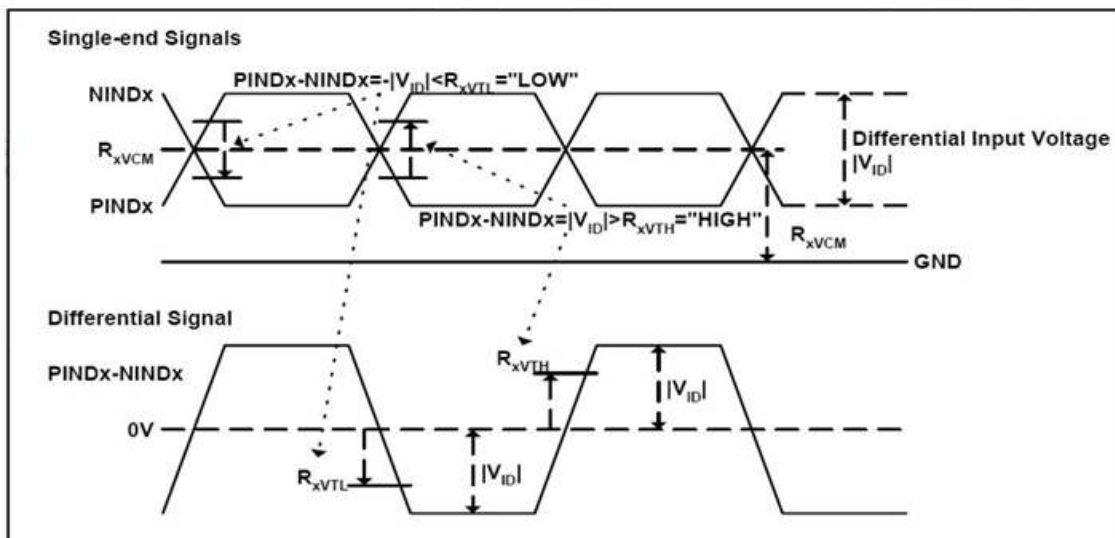

8.4 Timing Characteristics

Item	Symbol	Values			Unit	Remark
		Min	Typ	Max		
Clock frequency	Fclk	40.8	51.2	67.2	MHz	Frame rate=60Hz
Horizontal display area	Thd	1024			DCLK	
HS period time	Th	1114	1344	1400	DCLK	
HS Blanking	Thb	90	320	376	DCLK	
Vertical display area	Tvd	600			H	
VS period time	Tv	610	635	800	H	
VS blanking	Thb	10	35	200	H	



8.5 Data Input Format

6bit LVDS input

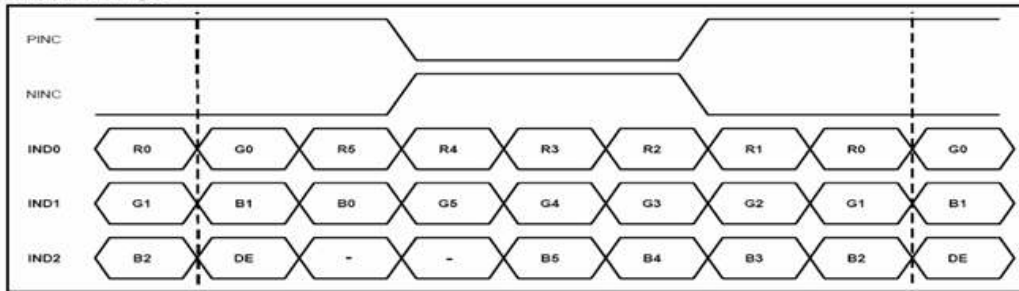

8bit LVDS input

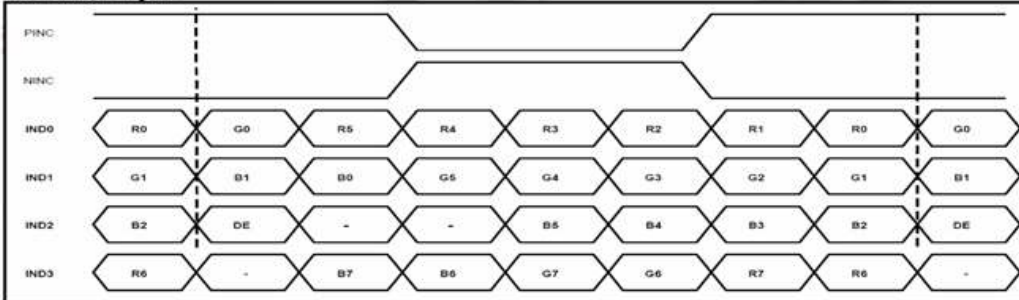

Note: Support DE timing mode only, SYNC mode not supported.

9.0 Reliability Test Condition

Item		Test Condition
Operating	High Temperature	70degC, 240 hrs
	Low Temperature	-20degC, 240 hrs
Storage	High Temperature	80degC, 240hrs and recovery for 2hrs
	Low Temperature	-30degC, 240hrs and recovery for 2hrs
	High Temperature and High Humidity	50degC, 90%RH, 240hrs and recovery for 2 hrs
Thermal	Cycle	RT → -30degC → Rt → 80degC → RT 0min 30min 5min 30min 5min 50 cycles (Power off)
	Shock	RT → -30degV → 80degC 0min 30min 30min 50 cycles (Power off)

Note: RT means Room temperature

10.0 Inspection Criteria

No	Defect	Definition of defect	Inspection Criteria															
1	a) Definition of dot	<p>The size of defective dot over 1/2 of whole is regards as one defective dot.</p> <p>Smaller than 1/2 Larger than 1/2</p> <p>'No dot defect' (ignore) '1 dot defect' (counted)</p>	<p>A – Viewing area B – Viewing area C – Outside Viewing area</p>															
	b) Bright Dot	Dot appear bright and unchanged in size when LCD panel is displaying black pattern	<table border="1"> <tr> <th>Defect</th> <th>A</th> <th>B</th> <th>C</th> </tr> <tr> <td>Bright Dot</td> <td>1</td> <td>1</td> <td rowspan="2">NC</td> </tr> <tr> <td>Dark Dot</td> <td>2</td> <td>2</td> </tr> <tr> <td>Total</td> <td colspan="2">4</td> <td></td> </tr> </table> <p>NC – Not Count</p>	Defect	A	B	C	Bright Dot	1	1	NC	Dark Dot	2	2	Total	4		
	Defect	A	B	C														
	Bright Dot	1	1	NC														
Dark Dot	2	2																
Total	4																	
c) Dark Dot	Dot appear dark and unchanged in size when LCD panel is displaying pure color (RED, GREEN or BLUE) pattern	<table border="1"> <tr> <th>Defect</th> <th>A</th> <th>B</th> <th>C</th> </tr> <tr> <td>Bright Dot</td> <td>1</td> <td>1</td> <td rowspan="2">NC</td> </tr> <tr> <td>Dark Dot</td> <td>2</td> <td>2</td> </tr> <tr> <td>Total</td> <td colspan="2">4</td> <td></td> </tr> </table> <p>NC – Not Count</p>	Defect	A	B	C	Bright Dot	1	1	NC	Dark Dot	2	2	Total	4			
Defect	A	B	C															
Bright Dot	1	1	NC															
Dark Dot	2	2																
Total	4																	
d) 2 dot adjacent	<p>1 pair = 2 dots</p> <p>Type 1 Type 2</p> <p>Type 3 or Type 3</p>	<table border="1"> <tr> <th>Defect</th> <th>Acc. Count</th> </tr> <tr> <td>2 Bright dot Adjacent</td> <td>0</td> </tr> <tr> <td>2 Dark dot Adjacent</td> <td>1</td> </tr> </table>	Defect	Acc. Count	2 Bright dot Adjacent	0	2 Dark dot Adjacent	1										
Defect	Acc. Count																	
2 Bright dot Adjacent	0																	
2 Dark dot Adjacent	1																	
2	<p>Black spot White Spot Bright spot Pin Hole Foreign Particle</p>	<p>-Black/Dark/Bright Spot is points on display which appear dark/bright and usually result from contamination - These defect do not vary in size intensity (contrast) when contras is varied.</p> <p>$D = \frac{a+b}{2}(\text{mm})$</p>	<table border="1"> <tr> <th>Defect Category</th> <th>A</th> <th>B</th> </tr> <tr> <td>$D \leq 0.10$</td> <td>NC</td> <td rowspan="4">NC</td> </tr> <tr> <td>$0.10 \leq D \leq 0.20$</td> <td>2</td> </tr> <tr> <td>$0.20 \leq D \leq 0.30$</td> <td>1</td> </tr> <tr> <td>$D \geq 0.30$</td> <td>0</td> </tr> </table>	Defect Category	A	B	$D \leq 0.10$	NC	NC	$0.10 \leq D \leq 0.20$	2	$0.20 \leq D \leq 0.30$	1	$D \geq 0.30$	0			
Defect Category	A	B																
$D \leq 0.10$	NC	NC																
$0.10 \leq D \leq 0.20$	2																	
$0.20 \leq D \leq 0.30$	1																	
$D \geq 0.30$	0																	
3	<p>Black Line White line Particle between POL and Glass Scratch on Glass</p>		<table border="1"> <tr> <th>Defect Category</th> <th>A</th> <th>B</th> </tr> <tr> <td>$W \leq 0.03$</td> <td>NC</td> <td rowspan="3">NC</td> </tr> <tr> <td>$0.03 \leq W \leq 0.08, L \leq 2.0$</td> <td>2</td> </tr> <tr> <td>$W \geq 0.08$</td> <td>0</td> </tr> </table>	Defect Category	A	B	$W \leq 0.03$	NC	NC	$0.03 \leq W \leq 0.08, L \leq 2.0$	2	$W \geq 0.08$	0					
Defect Category	A	B																
$W \leq 0.03$	NC	NC																
$0.03 \leq W \leq 0.08, L \leq 2.0$	2																	
$W \geq 0.08$	0																	
4	<p>POL Bubble POL Dented</p>		<table border="1"> <tr> <th>Defect Category</th> <th>A</th> <th>B</th> </tr> <tr> <td>$D \leq 0.20$</td> <td>NC</td> <td rowspan="4">NC</td> </tr> <tr> <td>$0.20 \leq D \leq 0.30$</td> <td>3</td> </tr> <tr> <td>$0.30 \leq D \leq 0.50$</td> <td>2</td> </tr> <tr> <td>$D \geq 0.5$</td> <td>0</td> </tr> </table>	Defect Category	A	B	$D \leq 0.20$	NC	NC	$0.20 \leq D \leq 0.30$	3	$0.30 \leq D \leq 0.50$	2	$D \geq 0.5$	0			
Defect Category	A	B																
$D \leq 0.20$	NC	NC																
$0.20 \leq D \leq 0.30$	3																	
$0.30 \leq D \leq 0.50$	2																	
$D \geq 0.5$	0																	
5	<p>Mura (50% Grey)</p>		<p>Judged by Limit sample</p>															



11.0 Precaution for Using TFT Modules

1. Handling Precautions

- a. The display panel is made of glass and polarizer. As glass is fragile. It tends to chip during handling especially on the edges. Please avoid dropping or jarring. Do not subject it to a mechanical shock of impact or by dropping it.
- b. If the display panel is damaged and the liquid crystal substance leaks out, be sure not to get any in your mouth. If the substance is in contact with your skin or clothes, wash it off using soap and water.
- c. Do not apply excessive force to the display surface or the adjoining areas since this may cause the color tone to vary. Do not touch the display with bare hands. This will stain the display area and degrade the insulation between terminals. Scratch and dents may occur on polarizer too.
- d. The polarizer covering the display surface of the LCD module is soft and easily scratched. Handle this polarizer carefully. Do not touch, push or rub the exposed polarizers with anything harder than a HB pencil lead (glass, tweezers, etc.). Do not put or attach anything on the display area to avoid leaving marks on it. Condensation on the surface and contact with terminals due to cold will damage, stain or dirty the polarizer. After products are tested at low temperature they must be warmed up in a container before coming in to contact with room temperature air.
- e. If the display surface becomes contaminated, breathe on the surface and gently wipe it with a soft dry cloth. If it is heavily contaminated, moisten cloth with one of the following solvents
 - Isopropyl alcohol
 - Ethyl alcohol
 - Do not scrub hard to avoid damaging the display surface.
- f. Solvents other than those above-mentioned may damage the polarizer. Especially, do not use the following.
 - Water
 - Ketone
 - Aromatic solvents
 - Wipe off saliva or water drops immediately, contact with water over a long period of time may cause deformation or color fading. Avoid contact with oil and fats.
- g. Exercise care to minimize corrosion of the electrode. Corrosion of the electrodes is accelerated by water droplets, moisture condensation or a current flow in a high-humidity environment.
- h. Install the LCD Module by using the mounting holes. When mounting the LCD module make sure it is free of twisting, warping and distortion. In particular, do not forcibly pull or bend the I/O cable or the backlight cable.
- i. Do not attempt to disassemble or process the LCD module.
- j. NC terminal should be open. Do not connect anything.
- k. If the logic circuit power is off, do not apply the input signals.
- l. Electro-Static Discharge Control. Since this module uses a CMOS LSI, the same careful attention should be paid to electrostatic discharge as for an ordinary CMOS IC. To prevent destruction of the elements by static electricity, be careful to maintain an optimum work environment.
 - Before removing LCM from its packing case or incorporating it into a set, be sure the module and your body have the same electric potential. Be sure to ground the body when handling the LCD modules.
 - Tools required for assembly, such as soldering irons, must be properly grounded. Make certain the AC power source for the soldering iron does not leak. When using an electric screwdriver to attach LCM, the screw driver



should be of ground potentiality to minimize as much as possible any transmission of electromagnetic waves produced sparks coming from the commutator of the motor.

- To reduce the amount of static electricity generated, do not conduct assembly and other work under dry conditions. To reduce the generation of static electricity be careful that the air in the work environment is not too dry. A relative humidity of 50%-60% is recommended. As far as possible make the electric potential of your work clothes and that of the work bench the ground potential.
 - The LCD module is coated with a film to protect the display surface. Exercise care when peeling off this protective film since static electricity may be generated.
- m. Since LCM has been assembled and adjusted with a high degree of precision, avoid applying excessive shocks to the module or making any alterations or modifications to it.
- Do not alter, modify or change the shape of the tab on the metal frame.
 - Do not make extra holes on the printed circuit board, modify its shape or change the positions of components to be attached.
 - Do not damage or modify the pattern writing on the printed circuit board.
 - Absolutely do not modify the zebra rubber strip (conductive rubber) or heat seal connector.
 - Except for soldering the interface, do not make any alterations or modifications with a soldering iron.
 - Do not drop, bend or twist the LCM.

2. Storage Precautions

When storing the LCD modules, the following precaution are necessary.

- a. Store them in a sealed polyethylene bag. If properly sealed, there is no need for the desiccant.
- b. Store them in a dark place. Do not expose to sunlight or fluorescent light, keep the temperature between 0°C and 35°C, and keep the relative humidity between 40%RH and 60%RH.
- c. The polarizer surface should not come in contact with any other objects.

3. Others

- a. Liquid crystals solidify under low temperature (below the storage temperature range) leading to defective orientation or the generation of air bubbles (black or white). Air bubbles may also be generated if the module is subject to a low temperature.
- b. If the LCD modules have been operating for a long time showing the same display patterns, the display patterns may remain on the screen as ghost images and a slight contrast irregularity may also appear. A normal operating status can be regained by suspending use for some time. It should be noted that this phenomenon does not adversely affect performance reliability.
- c. To minimize the performance degradation of the LCD modules resulting from destruction caused by static electricity etc. Exercise care to avoid holding the following sections when handling the modules.
 - Exposed area of the printed circuit board.
 - Terminal electrode sections.

4. Using LCD Modules

a. Installing LCD Modules

The hole in the printed circuit board is used to fix LCM as shown in the picture below.

Attend to the following items when installing the LCM.

- b. Cover the surface with a transparent protective plate to protect the polarizer and LC cell.

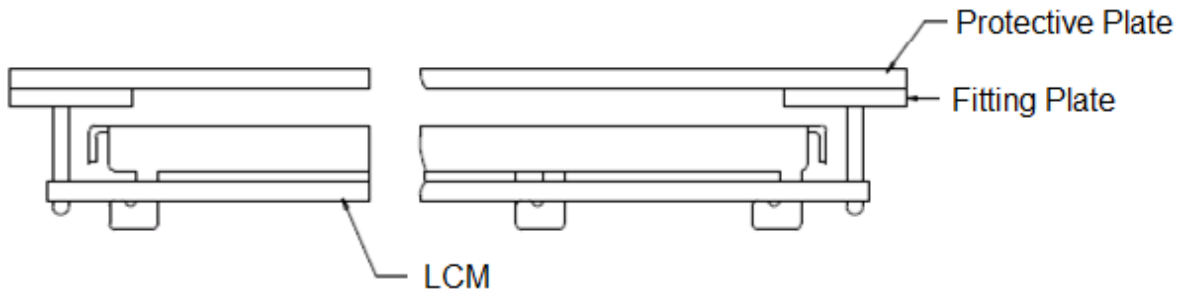

- c. When assembling the LCM into other equipment, the spacer to the bit between the LCM and the fitting plate should have enough height to avoid causing stress to the module surface, refer to the individual specifications for measurements. The measurement tolerance should be 0.1mm.
- d. Precaution for assemble the module with BTB connector:
Please note the position of the male and female connector position, don't assemble or assemble like the method which the following picture shows

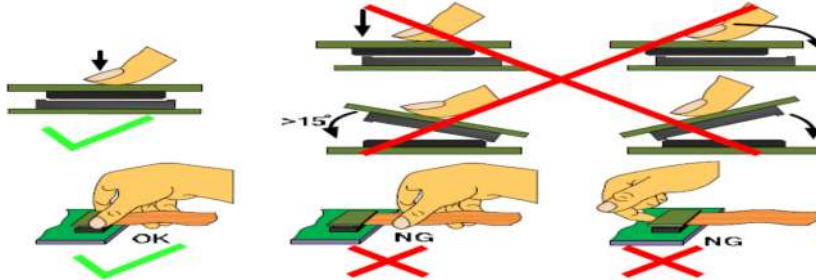

5. Precaution for soldering the LCM

	Manual soldering	Machine drag soldering	Machine press soldering
No RoHS Product	290°C ~350°C. Time: 3-5S.	330°C ~350°C. Speed: 4-8 mm/s.	300°C ~330°C. Time: 3-6S. Press: 0.8~1.2Mpa
RoHS Product	340°C ~370°C. Time: 3-5S.	350°C ~370°C. Time: 4-8 mm/s.	330°C ~360°C. Time: 3-6S. Press: 0.8~1.2Mpa

- a. If soldering flux is used, be sure to remove any remaining flux after finishing the soldering operation (This does not apply in the case of a non-halogen type of flux). It is recommended that you protect the LCD surface with a cover during soldering to prevent any damage due to flux spatters.
- b. When soldering the electroluminescent panel and PC board, the panel and board should not be detached more than three times. This maximum number is determined by the temperature and time conditions mentioned above, though there may be some variance depending on the temperature of the soldering iron.
- c. When removing the electroluminescent panel from the PC board, be sure the solder has completely melted, the soldered pad on the PC board could be damaged.



6. Precautions for Operation

- a. Viewing angle varies with the change of liquid crystal driving voltage (VLCD). Adjust VLCD to show the best contrast.
- b. It is recommended to drive LCD's within the specified voltage limit since over limit will cause shorter LCD life. An electrochemical reaction due to direct current causes LCD-deterioration. Avoid the use of direct current drive.
- c. Response time will be extremely delayed at lower temperature compared to room operating temperature range and on the other hand, at higher temperature LCD shows dark color in them. However those phenomena do not mean malfunction. The LCD will return to normal performance when ambient temperature revert to room condition.
- d. If the display area is pushed hard during operation, the display will become abnormal. However, it will return to normal if it is turned off and on.
- e. A slight dew depositing on terminals is a cause for electro-chemical reaction resulting in terminal open circuit.
- f. Input logic voltage before apply analogue high voltage such as LCD driving voltage when power on. Remove analogue high voltage before logic voltage when power off the module. Input each signal after the positive/negative voltage becomes stable.
- g. Please keep the temperature within the specified range for use and storage. Polarization degradation, bubble generation or polarizer peel-off may occur with high temperature and high humidity.

7. Safety

- a. It is recommended to crush damaged or unnecessary LCDs into pieces and wash them off with solvents such as acetone and ethanol, which should later be burned.
- b. If any liquid leaks out of a damaged glass cell and comes in contact with the hands, wash off thoroughly with soap and water.

8. Limited Warranty

Unless otherwise agreed between Crystal Clear Technology and customer, Crystal Clear Technology will replace or repair any of its LCD and LCM which is found to be defective electrically and visually when inspected in accordance with Crystal Clear Technology acceptance standards, for a period of one year from date of shipment. Confirmation of such date shall be based on freight documents. The warranty liability of Crystal Clear Technology is limited to repair and/or replacement on the terms set forth above. Crystal Clear Technology will not responsible for any subsequent or consequential events.

9. Return LCM under Warranty

No warranty can be granted if the precautions stated above have been disregarded. The typical examples of violations are:

- Broken LCD glass
- PCB eyelet's damaged or modified
- PCB conductors damaged
- Circuit modified in any way, including addition of components.
- PCB tampered with by grinding, engraving or painting varnish.
- Soldering to, or modifying the bezel in any manner.

Module repairs will be invoiced to customer upon mutual agreement. Modules must be returned with sufficient description of failure or defects. Any connectors or cable installed by customer must be removed completely without damaging the PCB eyelet's, conductors and terminals.

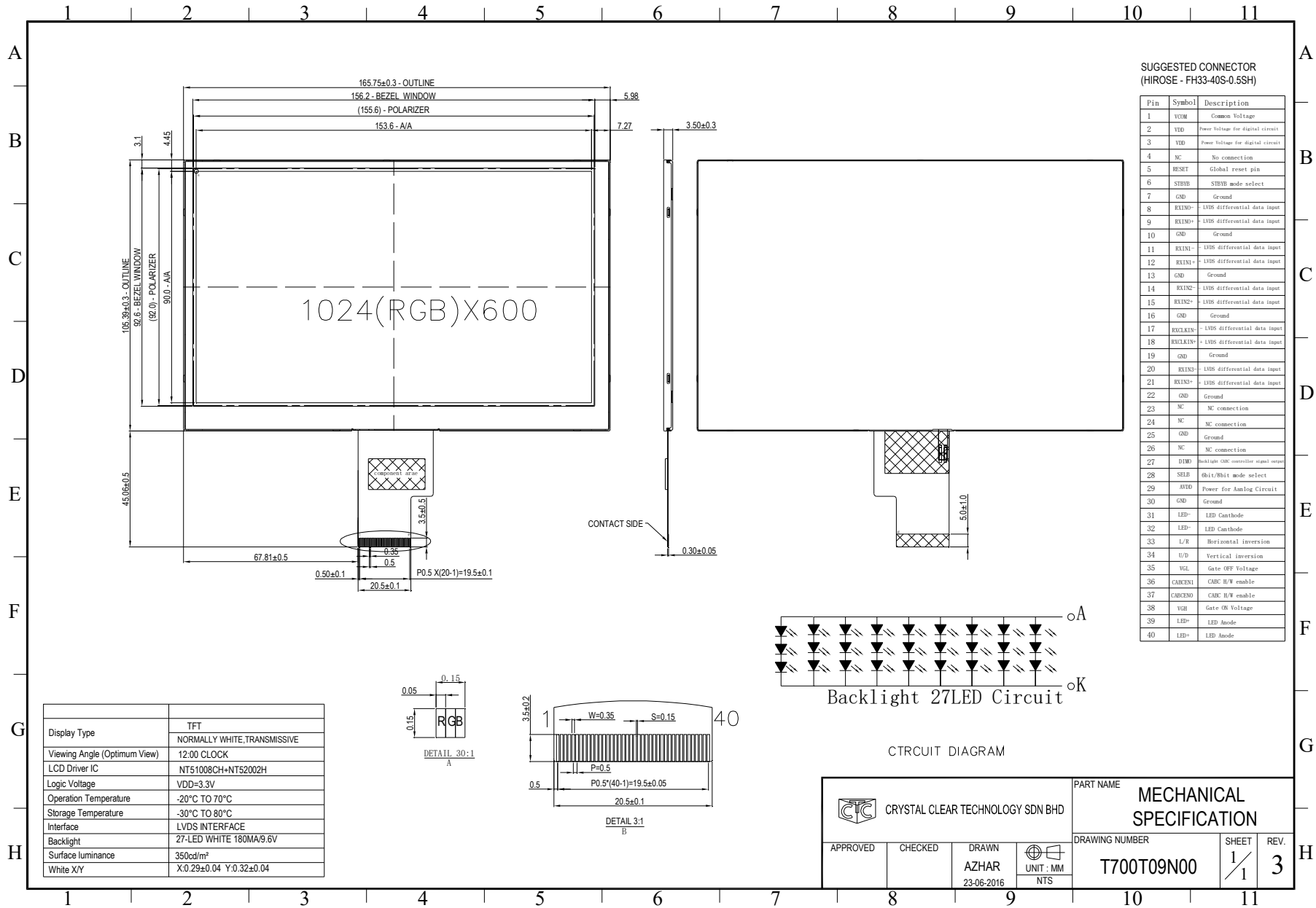

SUGGESTED CONNECTOR
(HIROSE - FH33-40S-0.5SH)

Pin	Symbol	Description
1	VCOM	Common Voltage
2	VDD	Power Voltage for digital circuit
3	VED	Power Voltage for digital circuit
4	NC	No connection
5	RESET	Global reset pin
6	STBYB	STBYB mode select
7	GND	Ground
8	RXIN0-	LVDS differential data input
9	RXIN0+	LVDS differential data input
10	GND	Ground
11	RXIN1-	LVDS differential data input
12	RXIN1+	LVDS differential data input
13	GND	Ground
14	RXIN2-	LVDS differential data input
15	RXIN2+	LVDS differential data input
16	GND	Ground
17	RXCLKIN-	LVDS differential data input
18	RXCLKIN+	LVDS differential data input
19	GND	Ground
20	RXIN3-	LVDS differential data input
21	RXIN3+	LVDS differential data input
22	GND	Ground
23	NC	NC connection
24	NC	NC connection
25	GND	Ground
26	NC	NC connection
27	TDIM	Backlight GND controller signal output
28	SELB	bBit/Bbit mode select
29	AVDD	Power for Analog Circuit
30	GND	Ground
31	LED-	LED Cathode
32	LED+	LED Cathode
33	L/R	Horizontal inversion
34	U/D	Vertical inversion
35	VGL	Gate OFF Voltage
36	CABCEN	CABC H/W enable
37	CABCEN0	CABC H/W enable
38	VGH	Gate ON Voltage
39	LED+	LED Anode
40	LED+	LED Anode

Display Type	TFT
Viewing Angle (Optimum View)	NORMALLY WHITE, TRANSMISSIVE
LCD Driver IC	12:00 CLOCK
Logic Voltage	NT51008CH+NT52002H
Operation Temperature	VDD=3.3V
Storage Temperature	-20°C TO 70°C
Interface	-30°C TO 80°C
Backlight	LVDS INTERFACE
Surface luminance	27-LED WHITE 180MA@9.6V
White XY	350cd/m²
	X:0.29±0.04 Y:0.32±0.04

CRYSTAL CLEAR TECHNOLOGY SDN BHD

MECHANICAL SPECIFICATION

APPROVED: [Signature] CHECKED: [Signature] DRAWN: AZHAR 23-06-2016 UNIT: MM NTS

PART NAME: T700T09N00

DRAWING NUMBER: 1/1

SHEET: 1/1

REV: 3

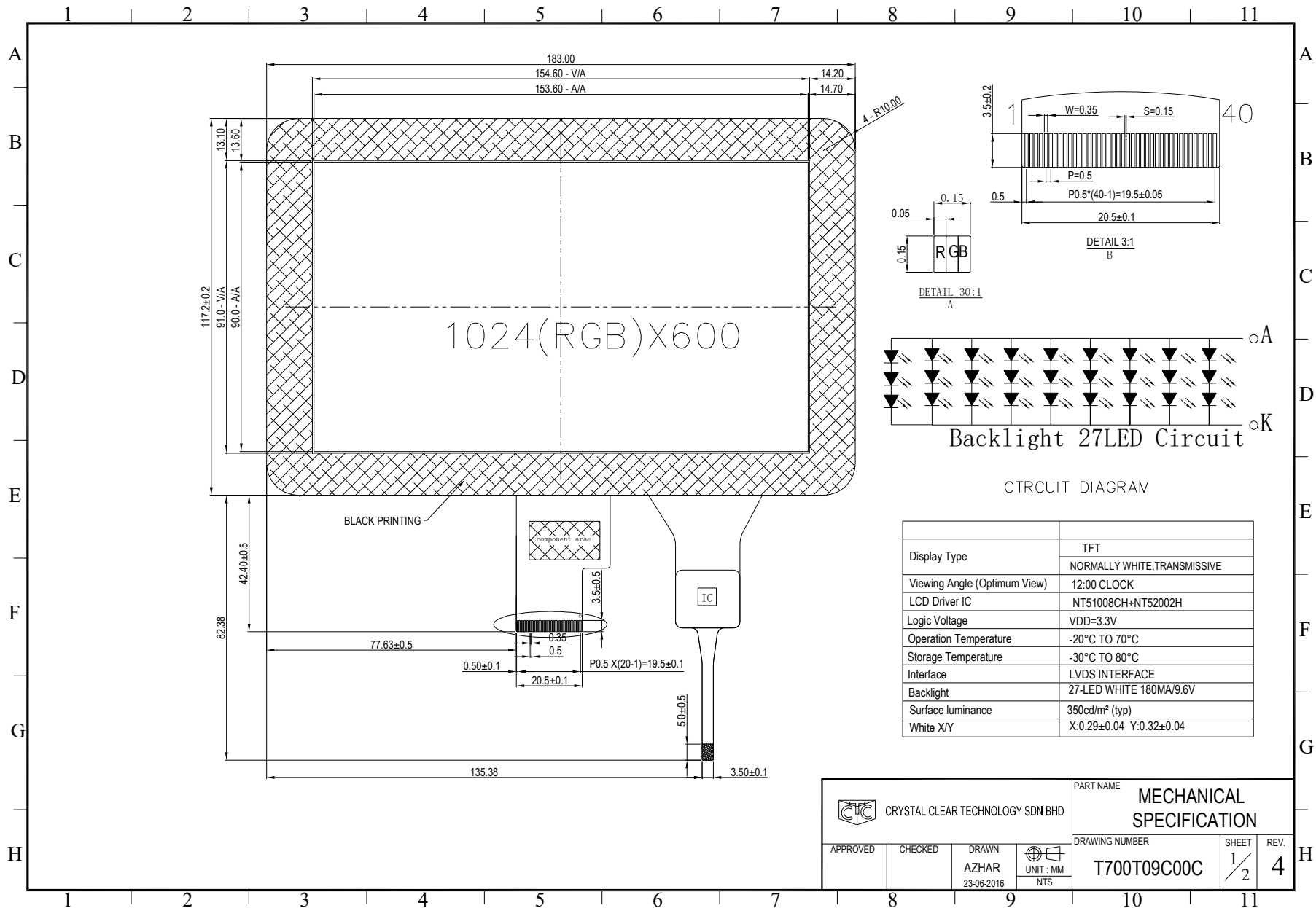

CRYSTAL CLEAR TECHNOLOGY SDN BHD		PART NAME	
		MECHANICAL SPECIFICATION	
APPROVED	CHECKED	DRAWN	DRAWING NUMBER
		AZHAR	T700T09C00C
		23-06-2016	SHEET 1/2
		UNIT: MM	REV. 4
		NTS	

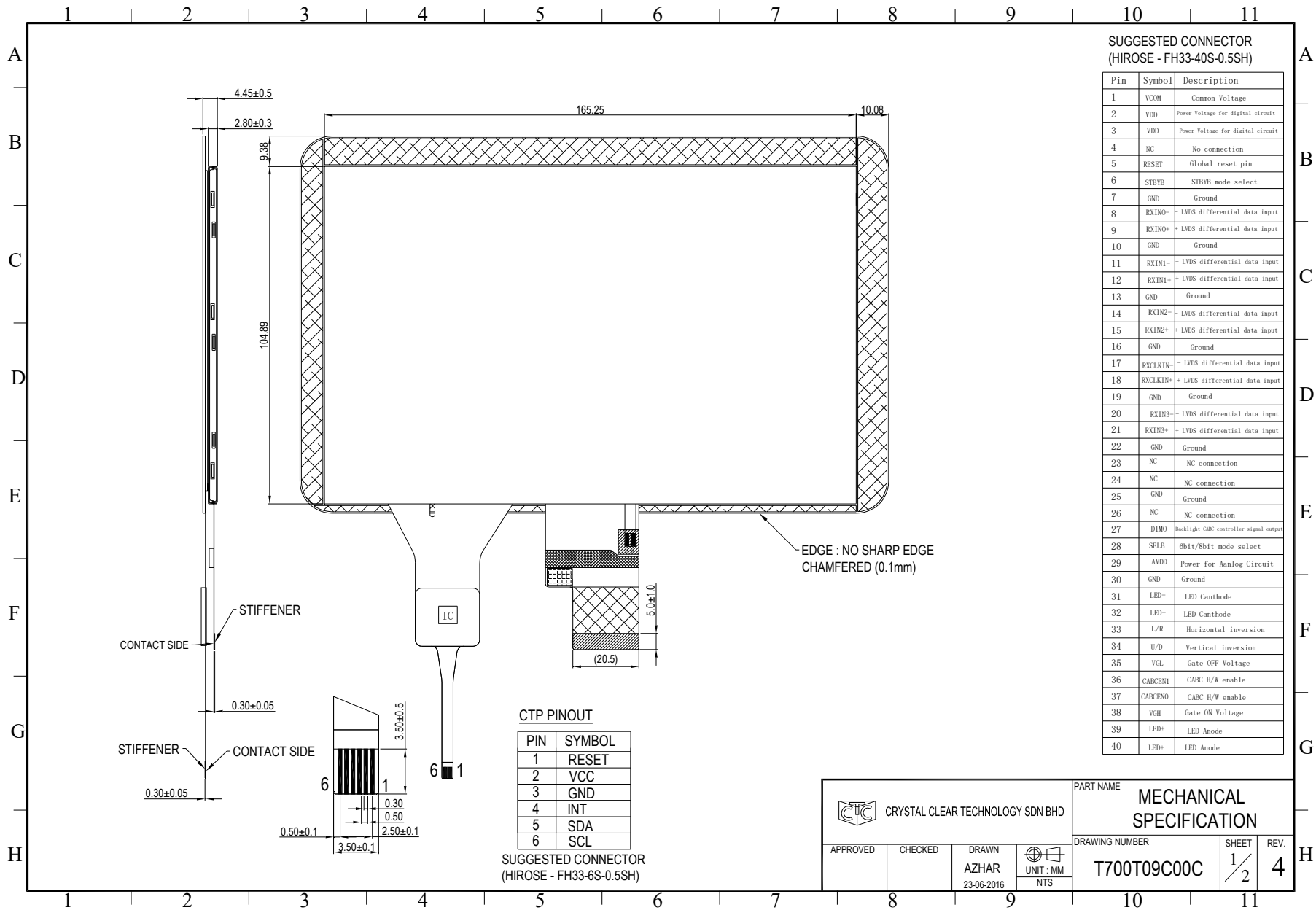

**SUGGESTED CONNECTOR
(HIROSE - FH33-40S-0.5SH)**

Pin	Symbol	Description
1	VCOM	Common Voltage
2	VDD	Power Voltage for digital circuit
3	VDD	Power Voltage for digital circuit
4	NC	No connection
5	RESET	Global reset pin
6	STBYB	STBYB mode select
7	GND	Ground
8	RXIN0-	- LVDS differential data input
9	RXIN0+	+ LVDS differential data input
10	GND	Ground
11	RXIN1-	- LVDS differential data input
12	RXIN1+	+ LVDS differential data input
13	GND	Ground
14	RXIN2-	- LVDS differential data input
15	RXIN2+	+ LVDS differential data input
16	GND	Ground
17	RXCLKIN-	- LVDS differential data input
18	RXCLKIN+	+ LVDS differential data input
19	GND	Ground
20	RXIN3-	- LVDS differential data input
21	RXIN3+	+ LVDS differential data input
22	GND	Ground
23	NC	NC connection
24	NC	NC connection
25	GND	Ground
26	NC	NC connection
27	DIM0	Backlight CBC controller signal output
28	SELB	6bit/8bit mode select
29	AVDD	Power for Analog Circuit
30	GND	Ground
31	LED-	LED Cathode
32	LED-	LED Cathode
33	L/R	Horizontal inversion
34	U/D	Vertical inversion
35	VGL	Gate OFF Voltage
36	CABCEN1	CABC H/W enable
37	CABCEN0	CABC H/W enable
38	VGH	Gate ON Voltage
39	LED+	LED Anode
40	LED+	LED Anode

CTP PINOUT

PIN	SYMBOL
1	RESET
2	VCC
3	GND
4	INT
5	SDA
6	SCL

SUGGESTED CONNECTOR
(HIROSE - FH33-6S-0.5SH)

CRYSTAL CLEAR TECHNOLOGY SDN BHD		PART NAME	
		MECHANICAL SPECIFICATION	
APPROVED	CHECKED	DRAWN	DRAWING NUMBER
		AZHAR	T700T09C00C
		23-06-2016	SHEET 1/2
		UNIT : MM NTS	REV. 4

CRYSTAL CLEAR TECHNOLOGY

Product Specification

TP0085

Crystal Clear Technology sdn. bhd.

16Jalan TP5—Taman Perindustrian Sime UEP
47600 Subang Jaya—Selangor DE
Malaysia. T: +603 80247099 F: +603 80247098



Contents

No	Title	Page
1	INTRODUCTION	16
2	GENERAL DESCRIPTION	16
3	ABSOLUTE MAXIMUM RATING	17
4	INTERFACE CHARACTERISTICS	17
5	ELECTRICAL CHARACTERISTICS	18
6	12C INTERFCE	18
7	MECHANICAL SPECIFICATION	20



1. Introduction

The purpose of this specification is defined the general provision and quality requirement apply to 7 inch Capacitive Touch module integrated by Crystal Clear Technology. This document, together with the module drawing, is the highest level specification for this product. When users touch module by finger, the module can send coordinates of point at the contact point to host. The finger position information is sent to host by I2C bus which is determined by host through IRQ line.

2. General Description

This document contains the Capacitive Touch module specification. The maximum rating, characteristics, hardware, and inspection of the module are described in the subsequent sections. In special, I2C protocol will be introduced in detail.

2.1. Touch sensor characteristics

- Technology: Use the character of capacitive among the touch electrodes on touch panel to identify the positions of touch signals
- Touch method: Ten fingers multi touch with pressure sensing
- Interface: I2C

2.2. General Specification

Item	Specification	Unit
Screen Diagonal	7.0	Inch
Applied Resolution	1024 x 600	pixel
Module Outline	100(H) x 164.1(W) x 1.4(T) (Excluded FPC)	Mm
Touch Area	(H) x (W)	Mm
Cover Lens Material	Glass	-
Transparency	85	%
Origin	-	-
Controller	GT911	-



3. Absolute Maximum Ratings

Absolute Maximum rating of touch panel module is as following

Symbol	Parameter	Value	Unit
VDDIO	Supply Voltage for I/O	-0.3 to +3.3	V
TA	Operating Temperature	-20 to +85	°C
TSTG	Storage Temperature	-30 to +85	°C

Note: If the module exceeds the absolute maximum ratings, it may be damaged permanently. Also, if the module operated with the absolute maximum ratings for a long time, its reliability may drop.

4. Electrical Characteristics

DC Characteristics (Unless otherwise specified, Voltage Referenced to VSS, TA = -20 to 85°C)

Symbol	Parameter	Conditions	Min	Typ	Max	Unit
AVDD	Analog power supply		2.8	-	3.3	V
VDDIO	Digital I/O power supply		1.8	-	3.3	V
IDD	Operating mode current		-	8	14.5	mA
IGR	Green mode current		-	3.3	-	mA
Isleep	Sleep mode current		70	-	120	uA
VOH1	Logic High Output Voltage		0.85* VDDIO	-	-	V
VOL1	Logic Low Output Voltage		-	-	0.15* VDDIO	V
VIH1	Logic High Input voltage		0.75* VDDIO	-	VDDIO +3	V
VIL1	Logic Low Input voltage		-0.3	-	0.25* VDDIO	V



5. Pin Definition

Recommended connector: FH33-6S-0.5SH (Hirose)

No.	Symbol	I/O	Function
1	RST	I	Sensor system global reset
2	VDD	P	Power supply
3	VSS	P	Ground
4	IRQ	O	Sensor data ready request
5	SDA	I/O	I2C serial data
6	SCL	I	I2C serial clock

6. I2C Interface

Touch panel is used as I2C Slave Device, I2C Slave address is 0x14.

6.1. Interface Diagram

The system block diagram is as shown in below. There are three communication pins connected between CPU and Touch Panel Module which are including external interrupt IRQ, I2C pins SCL and SDA. The IRQ is active low while the touch state is calculated by Touch Panel Module and the touch information can be translated via I2C communication interface. The I2C data format, protocol and report packet are described as following.

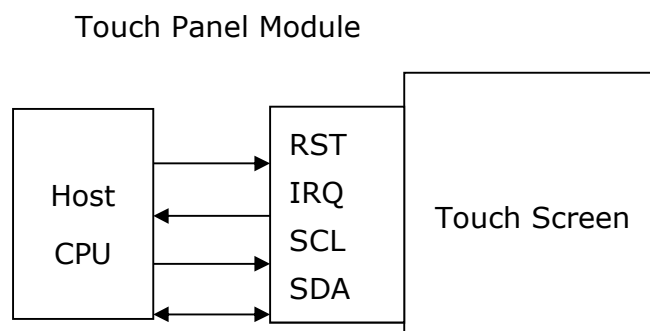



6.2. Timing Characteristic

Conditions:

$V_{DD} - V_{SS} = 2.5 \text{ TO } 3.3\text{V}$

$T_A = 25^\circ\text{C}$

400Kbps transmission rate, 2K pull-up resistor

Symbol	Parameter	Min	Typ	Max	Unit
T _{lo}	SCL low period	1.3	-	-	US
t _{hi}	SCL high period	0.6	-	-	US
t _{st1}	SCL setup time for Start condition	0.6	-	-	US
t _{st3}	SCL setup time for Start condition	0.6	-	-	US
t _{hd1}	SCL setup time for Start condition	0.6	-	-	US
t _{st2}	SDA setup time	0.1	-	-	US
t _{hd2}	SDA hold time	0	-	-	US

Power On Timing:

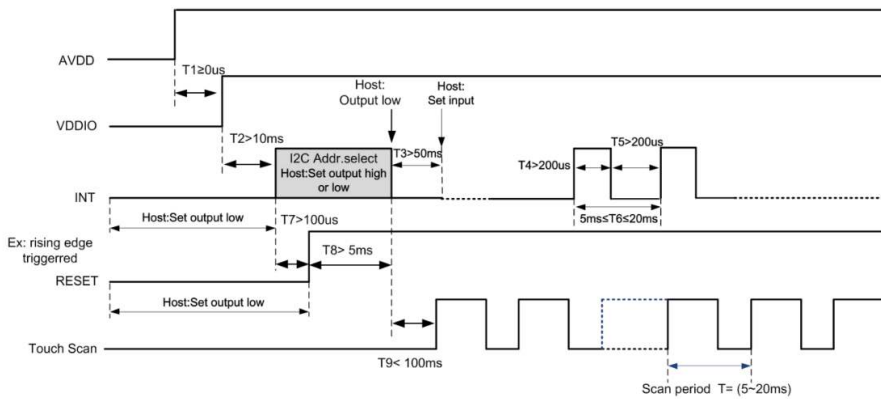

Timing for host resetting

